

SIGMA
TOOLINGS

SIGMA
SPINDLE
TOOLING
A Tool Holder
Company



FRONT SIDE END PAPER 1

FRONT SIDE END PAPER 2

PRODUCT RANGE



SIGMA SPINDLE TOOLING

Sr. No.	Description	Page No.
①	Precision Tool Holders: HSK - A (DIN 69893 - 1)	2 - 29
②	Precision Tool Holders: BT (MAS 403) DIN ISO 7388 - 2	30 - 61
③	Precision Tool Holders: BBT (BT MAS 403) (Taper & Both Face Contact Holders)	62 - 97
④	Precision Tool Holders: SK (DIN 69871) DIN ISO 7388 - 1	98 - 131
⑤	Precision Tool Holders & Quick Change Tapping Chucks (With Cyl. Shank & Morse Tapper Shank)	132 - 147
⑥	Accessories for Precision Tool Holders & Tapping Chucks	148 - 218

Declaration





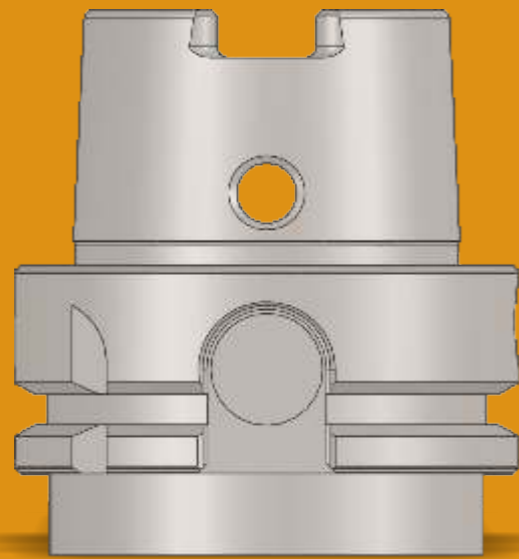

 **This Logo is the registered Trade Mark Sigma Toolings**

The information in this catalogue is believed to be correct. Sigma Toolings, however, assumes no responsibility for any errors, inaccuracies or omissions that may appear in this catalogue. Information this catalogue is subject to change without notice and should not be taken as a commitment by Sigma Toolings or its subsidiaries.





**Precision Tool Holders
HSK-A (DIN 69893-1)**



INDEX

Sr. No.	Contents		Page No.
①	Technical Information: HSK - A (DIN 69893-1)		5
②	Collet Chuck ER (DIN 6499) <ul style="list-style-type: none"> • Collet Chuck ER • Collet Chuck ER "M" Type 		6 - 7
③	Weldon Type End Mill Holders (DIN 6359) <ul style="list-style-type: none"> • Weldon (WE) 		8 - 9
④	Face Mill Holders (DIN 6357) <ul style="list-style-type: none"> • FMH • FMH-K (Through Coolant) 		10 - 11
⑤	Boring Bar Blank		12
⑥	Master Mandrell		13
⑦	NC Drill Chuck (NCDC)		14

INDEX

Sr. No.	Contents		Page No.
8	Die & Mould Chuck (DMC)		15 - 16
9	Power Milling Chuck (PMC)		17 - 18
10	Milling Cutter Arbor (MCA)		19 - 20
11	Shrink Fit Holders 4.5 Degree (SFH 4.5°) • Shrink Fit Holder (SFH 4.5°) • Shrink Fit Holder (SFH FCC 4.5°) (Face Coolant Channel)		21 - 27
12	Shrink Fit Holders Slim 3 Degree (SFH Slim 3°) • Shrink Fit Holder (SFH Slim 3°)		28 - 29

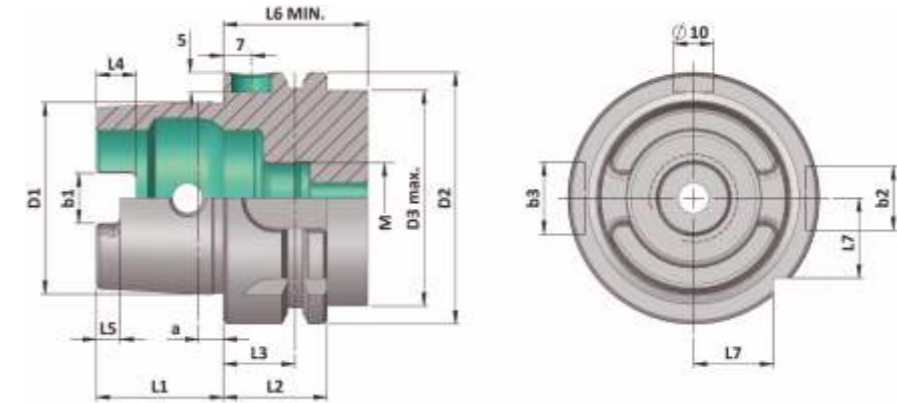

HSK-A	D1	D2	D3	a	b1	b2	b3	M	L1	L2	L3	L4	L5	L6	L7
50	38	50	42	5.0	10.54	12	14	M16X1	25	26	18	7.5	4.5	42	15.5
63	48	63	53	6.3	12.54	16	18	M18X1	32	26	18	10.0	6.0	42	20
100	75	100	88	10.0	20.02	20	22	M24X1.5	50	29	20	15.0	10.0	45	31.5

Material :- Case hardened steel, tensile strength in the core min. 950 N/mm²
 Execution :- Case hardened to HRC 58 ± 2, Case Depth 0.8 mm., Silver finish.
 Accuracy :- Taper Angle Class AT 3

HSK - A (DIN 69893 - 1) Holders

**HSK-A (DIN 69893-1)
Collet Chuck ER (DIN 6499)**

Maximum Run out of the Internal Taper with respect to the External Taper 0.005 mm

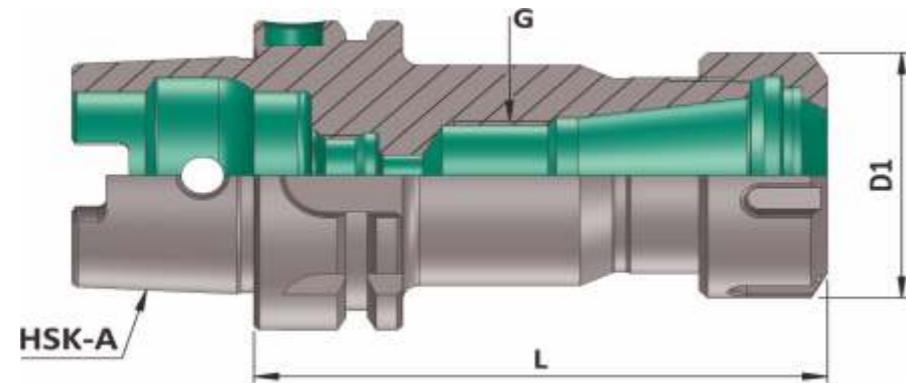

HSK-A (DIN 69893-1) Collet Chuck (ER)

(Balanced to 6.3 G 20000 RPM)

Item Name	Item Code	HSK-A	Suitable Collet	Collet Capacity	D1	G	L	Nut	Spanner
HSK-A 50 ER 16 060 6.3G 20000 SL	S10166149117209	50	ER 16	0.5-10	32	M10X1	60	UM/ER16	E16
HSK-A 50 ER 16 100 6.3G 20000 SL	S10166149148209	50	ER 16	0.5-10	32	M10X1	100	UM/ER16	E16
HSK-A 50 ER 20 100 6.3G 20000 SL	S10166150148209	50	ER 20	1.0-13	35	M10X1	100	UM/ER20	E20
HSK-A 50 ER 25 070 6.3G 20000 SL	S10166151125209	50	ER 25	1.0-16	42	M18X1	70	UM/ER25	E25
HSK-A 50 ER 25 100 6.3G 20000 SL	S10166151148209	50	ER 25	1.0-16	42	M18X1	100	UM/ER25	E25
HSK-A 50 ER 32 080 6.3G 20000 SL	S10166152131209	50	ER 32	2.0-20	50	M22X1.5	80	UM/ER32	E32
HSK-A 50 ER 32 100 6.3G 20000 SL	S10166152148209	50	ER 32	2.0-20	50	M22X1.5	100	UM/ER32	E32
HSK-A 50 ER 40 080 6.3G 20000 SL	S10166153131209	50	ER 40	3.0-26	63	M30X1.5	80	UM/ER40	E40

HSK-A 63 ER 16 100 6.3G 20000 SL	S10167149148209	63	ER 16	0.5-10	32	M10X1	100	UM/ER16	E16
HSK-A 63 ER 16 160 6.3G 20000 SL	S10167149175209	63	ER 16	0.5-10	32	M10X1	160	UM/ER16	E16
HSK-A 63 ER 20 100 6.3G 20000 SL	S10167150148209	63	ER 20	1.0-13	35	M10X1	100	UM/ER20	E20
HSK-A 63 ER 20 160 6.3G 20000 SL	S10167150175209	63	ER 20	1.0-13	35	M10X1	160	UM/ER20	E20
HSK-A 63 ER 25 100 6.3G 20000 SL	S10167151148209	63	ER 25	1.0-16	42	M18X1	100	UM/ER25	E25
HSK-A 63 ER 25 160 6.3G 20000 SL	S10167151175209	63	ER 25	1.0-16	42	M18X1	160	UM/ER25	E25
HSK-A 63 ER 32 100 6.3G 20000 SL	S10167152148209	63	ER 32	2.0-20	50	M22X1.5	100	UM/ER32	E32
HSK-A 63 ER 32 160 6.3G 20000 SL	S10167152175209	63	ER 32	2.0-20	50	M22X1.5	160	UM/ER32	E32
HSK-A 63 ER 40 120 6.3G 20000 SL	S10167153162209	63	ER 40	3.0-26	63	M30X1.5	120	UM/ER40	E40
HSK-A 63 ER 40 160 6.3G 20000 SL	S10167153175209	63	ER 40	3.0-26	63	M30X1.5	160	UM/ER40	E40

HSK-A 100 ER 25 100 6.3G 20000 SL	S10168151148209	100	ER 25	1.0-16	42	M18X1	100	UM/ER25	E25
HSK-A 100 ER 25 160 6.3G 20000 SL	S10168151175209	100	ER 25	1.0-16	42	M18X1	160	UM/ER25	E25
HSK-A 100 ER 32 100 6.3G 20000 SL	S10168152148209	100	ER 32	2.0-20	50	M22X1.5	100	UM/ER32	E32
HSK-A 100 ER 32 160 6.3G 20000 SL	S10168152175209	100	ER 32	2.0-20	50	M22X1.5	160	UM/ER32	E32
HSK-A 100 ER 40 120 6.3G 20000 SL	S10168153162209	100	ER 40	3.0-26	63	M30X1.5	120	UM/ER40	E40
HSK-A 100 ER 40 160 6.3G 20000 SL	S10168153175209	100	ER 40	3.0-26	63	M30X1.5	160	UM/ER40	E40

Note: All Dimensions are in mm
For Necessary Accessories Selection Please Go Through Page No. 7

**HSK-A (DIN 69893-1)
Collet Chuck ER-M Type (DIN 6499)**

Maximum Run out of the Internal Taper with respect to the External Taper 0.005 mm

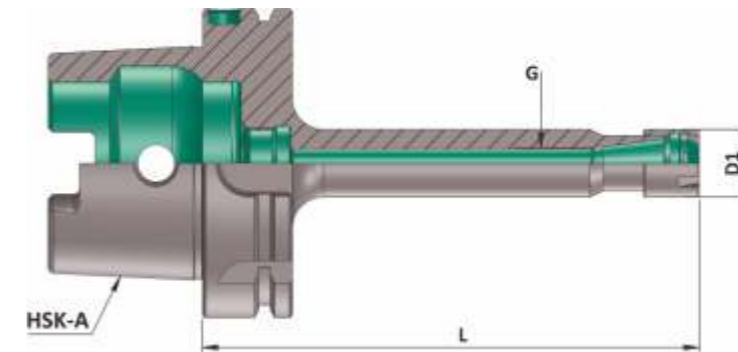

HSK-A (DIN 69893-1) Collet Chuck ER-M Type

(Balanced to 2.5 G 25000 RPM)

Item Name	Item Code	HSK-A	Suitable Collet	Collet Capacity	D1	G	L	Nut	Spanner
HSK-A 63 ER11M 100 2.5G 25000 SL	S10167156148114	63	ER 11	0.5-7	16	M6X1	100	ER11M	E11M
HSK-A 63 ER11M 160 2.5G 25000 SL	S10167156175114	63	ER 11	0.5-7	16	M6X1	160	ER11M	E11M
HSK-A 63 ER16M 100 2.5G 25000 SL	S10167157148114	63	ER 16	0.5-10	22	M10X1	100	ER16M	E16M
HSK-A 63 ER16M 160 2.5G 25000 SL	S10167157175209	63	ER 16	0.5-10	22	M10X1	160	ER16M	E16M
HSK-A 63 ER25M 100 2.5G 25000 SL	S10167159148209	63	ER 25	1.0-16	35	M18X1	100	ER25M	E25M
HSK-A 63 ER25M 160 2.5G 25000 SL	S10167159175209	63	ER 25	1.0-16	35	M18X1	160	ER25M	E25M
HSK-A 100 ER16M 100 2.5G 25000 SL	S10168157148209	100	ER 16	0.5-10	22	M10X1	100	ER16M	E16M

Accessories:

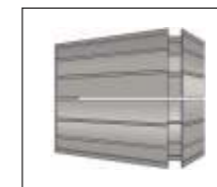

Collet ER (DIN 6499)
Ref. Page No. 164-168



Tap Collet ER-G
Ref. Page No. 169-171



Q.C.Tap Collet QCTC
Ref. Page No. 174-182



Sealing Disc
Ref. Page No. 157-162



ER Nut & ER Sealed Nut & ER M Nut
Ref. Page No. 151-152 & 155-156



ER Spanner & ER M Type Spanner
Ref. Page No. 153

Note: All Dimensions are in mm

HSK-A (DIN 69893-1)
Weldon Type End Mill Holder (DIN 1835 B)
(WE) (DIN 6359)

Maximum Run out of the Internal Dia with respect to the External Taper 0.005 mm

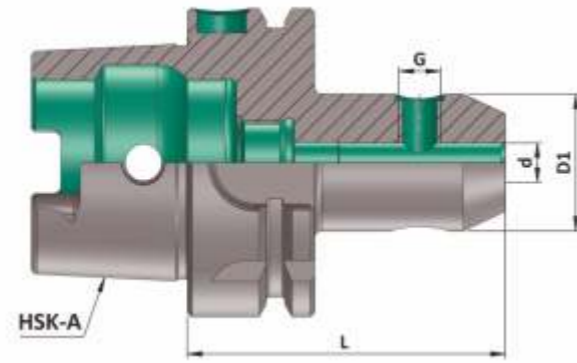

HSK-A (DIN 69893-1) (WE)

(Balanced to 6.3 G 20000 RPM)

Item Name	Item Code	HSK-A	d	D1	G	L	Screw Qty
HSK-A 50 WE06 065 6.3G 20000 SL	S10166111123209	50	6	25	M6	65	1
HSK-A 50 WE08 065 6.3G 20000 SL	S10166112123209	50	8	28	M8	65	1
HSK-A 50 WE10 065 6.3G 20000 SL	S10166113123209	50	10	35	M10	65	1
HSK-A 50 WE12 080 6.3G 20000 SL	S10166114131209	50	12	42	M12	80	1
HSK-A 50 WE14 080 6.3G 20000 SL	S10166258131209	50	14	44	M12	80	1
HSK-A 50 WE16 080 6.3G 20000 SL	S10166115131209	50	16	48	M14	80	1
HSK-A 50 WE18 080 6.3G 20000 SL	S10166259131209	50	18	50	M14	80	1
HSK-A 50 WE20 080 6.3G 20000 SL	S10166116131209	50	20	52	M16	80	1
HSK-A 50 SLA 25 100 6.3G 20000 SL	S10166107148209	50	25	50	M10	100	1

HSK-A 63 WE06 065 6.3G 20000 SL	S10167111123209	63	6	25	M6	65	1
HSK-A 63 WE06 100 6.3G 20000 SL	S10167111148209	63	6	25	M6	100	1
HSK-A 63 WE06 160 6.3G 20000 SL	S10167111175209	63	6	25	M6	160	1
HSK-A 63 WE08 065 6.3G 20000 SL	S10167112123209	63	8	28	M8	65	1
HSK-A 63 WE08 100 6.3G 20000 SL	S10167112148209	63	8	28	M8	100	1
HSK-A 63 WE08 160 6.3G 20000 SL	S10167112175209	63	8	28	M8	160	1
HSK-A 63 WE10 065 6.3G 20000 SL	S10167113123209	63	10	35	M10	65	1
HSK-A 63 WE10 100 6.3G 20000 SL	S10167113148209	63	10	35	M10	100	1
HSK-A 63 WE10 160 6.3G 20000 SL	S10167113175209	63	10	35	M10	160	1
HSK-A 63 WE12 080 6.3G 20000 SL	S10167114131209	63	12	42	M12	80	1
HSK-A 63 WE12 100 6.3G 20000 SL	S10167114148209	63	12	42	M12	100	1
HSK-A 63 WE12 160 6.3G 20000 SL	S10167114175209	63	12	42	M12	160	1
HSK-A 63 WE14 080 6.3G 20000 SL	S10167258131209	63	14	44	M12	80	1
HSK-A 63 WE14 100 6.3G 20000 SL	S10167258148209	63	14	44	M12	100	1
HSK-A 63 WE14 160 6.3G 20000 SL	S10167258175209	63	14	44	M12	160	1
HSK-A 63 WE16 080 6.3G 20000 SL	S10167115131209	63	16	48	M14	80	1
HSK-A 63 WE16 100 6.3G 20000 SL	S10167115148209	63	16	48	M14	100	1
HSK-A 63 WE16 160 6.3G 20000 SL	S10167115175209	63	16	48	M14	160	1
HSK-A 63 WE18 080 6.3G 20000 SL	S10167259131209	63	18	50	M14	80	1
HSK-A 63 WE18 100 6.3G 20000 SL	S10167259148209	63	18	50	M14	100	1
HSK-A 63 WE18 160 6.3G 20000 SL	S10167259175209	63	18	50	M14	160	1

Note: All Dimensions are in mm
 These Holders are most suitable for Weldon Type End Mill as per standard DIN 1835 - B

HSK-A (DIN 69893-1)
Weldon Type End Mill Holder (DIN 1835 B)
(WE) (DIN 6359)

Maximum Run out of the Internal Dia with respect to the External Taper 0.005 mm

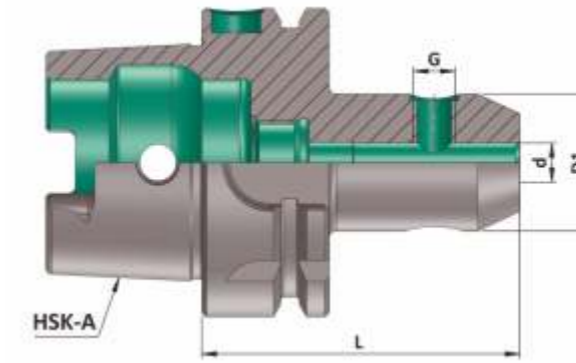

HSK-A (DIN 69893 - 1) WE

(Balanced to 6.3 G 20000 RPM)

Item Name	Item Code	HSK-A	d	D1	G	L	Screw Qty
HSK-A 63 WE 20 080 6.3G 20000 SL	S10167116131209	63	20	52	M16	80	1
HSK-A 63 WE 20 100 6.3G 20000 SL	S10167116148209	63	20	52	M16	100	1
HSK-A 63 WE 20 160 6.3G 20000 SL	S10167116175209	63	20	52	M16	160	1
HSK-A 63 WE 25 110 6.3G 20000 SL	S10167117156209	63	25	65	M18X2	110	2
HSK-A 63 WE 25 160 6.3G 20000 SL	S10167117175209	63	25	65	M18X2	160	2
HSK-A 63 WE 32 110 6.3G 20000 SL	S10167118156209	63	32	72	M20X2	110	2
HSK-A 63 WE 32 160 6.3G 20000 SL	S10167118175209	63	32	72	M20X2	160	2
HSK-A 63 WE 40 125 6.3G 20000 SL	S10167119164209	63	40	80	M20X2	125	2
HSK-A 63 WE 40 160 6.3G 20000 SL	S10167119175209	63	40	80	M20X2	160	2

HSK-A 100 WE 06 080 6.3G 20000 SL	S10168111131209	100	6	25	M6	80	1
HSK-A 100 WE 06 160 6.3G 20000 SL	S10168111175209	100	6	25	M6	160	1
HSK-A 100 WE 08 080 6.3G 20000 SL	S10168112131209	100	8	28	M8	80	1
HSK-A 100 WE 08 160 6.3G 20000 SL	S10168112175209	100	8	28	M8	160	1
HSK-A 100 WE 10 080 6.3G 20000 SL	S10168113131209	100	10	35	M10	80	1
HSK-A 100 WE 10 160 6.3G 20000 SL	S10168113175209	100	10	35	M10	160	1
HSK-A 100 WE 12 100 6.3G 20000 SL	S10168114148209	100	12	42	M12	100	1
HSK-A 100 WE 12 160 6.3G 20000 SL	S10168114175209	100	12	42	M12	160	1
HSK-A 100 WE 14 100 6.3G 20000 SL	S10168258148209	100	14	44	M12	100	1
HSK-A 100 WE 14 160 6.3G 20000 SL	S10168258175209	100	14	44	M12	160	1
HSK-A 100 WE 16 100 6.3G 20000 SL	S10168115148209	100	16	48	M14	100	1
HSK-A 100 WE 16 160 6.3G 20000 SL	S10168115175209	100	16	48	M14	160	1
HSK-A 100 WE 18 100 6.3G 20000 SL	S10168259148209	100	18	50	M14	100	1
HSK-A 100 WE 18 160 6.3G 20000 SL	S10168259175209	100	18	50	M14	160	1
HSK-A 100 WE 20 100 6.3G 20000 SL	S10168116148209	100	20	52	M16	100	1
HSK-A 100 WE 20 160 6.3G 20000 SL	S10168116175209	100	20	52	M16	160	1
HSK-A 100 WE 25 100 6.3G 20000 SL	S10168117148209	100	25	65	M18X2	100	2
HSK-A 100 WE 25 160 6.3G 20000 SL	S10168117175209	100	25	65	M18X2	160	2
HSK-A 100 WE 32 120 6.3G 20000 SL	S10168118162209	100	32	72	M20X2	120	2
HSK-A 100 WE 32 160 6.3G 20000 SL	S10168118175209	100	32	72	M20X2	160	2
HSK-A 100 WE 40 120 6.3G 20000 SL	S10168119162209	100	40	80	M20X2	120	2
HSK-A 100 WE 50 130 6.3G 20000 SL	S10168120165209	100	50	100	M24X2	130	2

Note: All Dimensions are in mm
 These Holders are most suitable for Weldon Type End Mill as per standard DIN 1835 - B

HSK-A (DIN 69893-1)
Face Mill Holder (DIN 6357) (FMH)

Maximum Run out of the External Dia with respect to the External Taper 0.005 mm

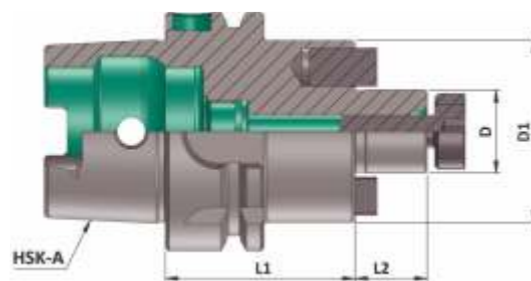

HSK-A(DIN 69893-1) (FMH)

(Balanced to 6.3 G 20000 RPM)

Item Name	Item Code	HSK-A	D	D1	L1	L2
HSK-A 50 FMH16 050 6.3G 20000 SL SP.S	S10166126111236	50	16	38	50	17
HSK-A 50 FMH22 060 6.3G 20000 SL SP.S	S10166127117236	50	22	48	60	19
HSK-A 50 FMH27 060 6.3G 20000 SL SP.S	S10166128117236	50	27	58	60	21
HSK-A 50 FMH32 060 6.3G 20000 SL SP.S	S10166129117236	50	32	78	60	24
HSK-A 63 FMH16 045 6.3G 20000 SL SP.S	S10167126108236	63	16	38	45	17
HSK-A 63 FMH16 100 6.3G 20000 SL SP.S	S10167126148236	63	16	38	100	17
HSK-A 63 FMH16 160 6.3G 20000 SL SP.S	S10167126175236	63	16	38	160	17
HSK-A 63 FMH22 050 6.3G 20000 SL SP.S	S10167127111236	63	22	48	50	19
HSK-A 63 FMH22 100 6.3G 20000 SL SP.S	S10167127148236	63	22	48	100	19
HSK-A 63 FMH22 160 6.3G 20000 SL SP.S	S10167127175236	63	22	48	160	19
HSK-A 63 FMH27 055 6.3G 20000 SL SP.S	S10167128115236	63	27	58	55	21
HSK-A 63 FMH27 100 6.3G 20000 SL SP.S	S10167128148236	63	27	58	100	21
HSK-A 63 FMH27 160 6.3G 20000 SL SP.S	S10167128175236	63	27	58	160	21
HSK-A 63 FMH32 060 6.3G 20000 SL SP.S	S10167129117236	63	32	78	60	24
HSK-A 63 FMH32 100 6.3G 20000 SL SP.S	S10167129148236	63	32	78	100	24
HSK-A 63 FMH32 160 6.3G 20000 SL SP.S	S10167129175236	63	32	78	160	24
HSK-A 63 FMH40 065 6.3G 20000 SL SP.S	S10167130123236	63	40	88	65	27
HSK-A 63 FMH40 100 6.3G 20000 SL SP.S	S10167130148236	63	40	88	100	27
HSK-A 63 FMH40 160 6.3G 20000 SL SP.S	S10167130175236	63	40	88	160	27
HSK-A 100 FMH16 055 6.3G 20000 SL SP.S	S10168126115236	100	16	38	55	17
HSK-A 100 FMH16 100 6.3G 20000 SL SP.S	S10168126148236	100	16	38	100	17
HSK-A 100 FMH16 160 6.3G 20000 SL SP.S	S10168126175236	100	16	38	160	17
HSK-A 100 FMH22 055 6.3G 20000 SL SP.S	S10168127115236	100	22	48	55	19
HSK-A 100 FMH22 100 6.3G 20000 SL SP.S	S10168127148236	100	22	48	100	19
HSK-A 100 FMH22 160 6.3G 20000 SL SP.S	S10168127175236	100	22	48	160	19
HSK-A 100 FMH27 055 6.3G 20000 SL SP.S	S10168128115236	100	27	58	55	21
HSK-A 100 FMH27 100 6.3G 20000 SL SP.S	S10168128148236	100	27	58	100	21
HSK-A 100 FMH27 160 6.3G 20000 SL SP.S	S10168128175236	100	27	58	160	21
HSK-A 100 FMH32 060 6.3G 20000 SL SP.S	S10168129117236	100	32	78	60	24
HSK-A 100 FMH32 100 6.3G 20000 SL SP.S	S10168129148236	100	32	78	100	24
HSK-A 100 FMH32 160 6.3G 20000 SL SP.S	S10168129175236	100	32	78	160	24
HSK-A 100 FMH40 065 6.3G 20000 SL SP.S	S10168130123236	100	40	88	65	27
HSK-A 100 FMH40 100 6.3G 20000 SL SP.S	S10168267148236	100	40	88	100	27
HSK-A 100 FMH40 160 6.3G 20000 SL SP.S	S10168608175236	100	40	88	160	27

HSK-A (DIN 69893-1)
Face Mill Holder (Through Coolant) (DIN 6357) (FMH-K)

Maximum Run out of the External Dia with respect to the External Taper 0.005 mm

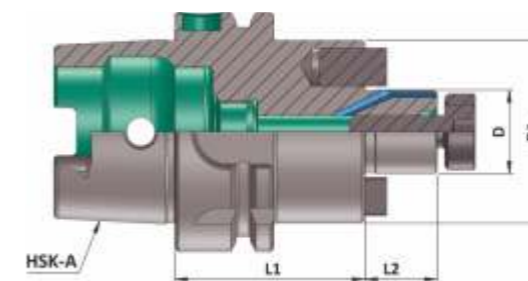

HSK-A(DIN 69893-1) (FMH-K)

(Balanced to 6.3 G 20000 RPM)

Item Name	Item Code	HSK-A	D	D1	L1	L2
HSK-A 50 FMH-K16 050 6.3G 20000 SL SP.S	S10166131111236	50	16	38	50	17
HSK-A 50 FMH-K22 060 6.3G 20000 SL SP.S	S10166132115236	50	22	48	60	19
HSK-A 50 FMH-K27 060 6.3G 20000 SL SP.S	S10166133117236	50	27	58	60	21
HSK-A 50 FMH-K32 060 6.3G 20000 SL SP.S	S10166134117236	50	32	78	60	24
HSK-A 63 FMH-K16 045 6.3G 20000 SL SP.S	S10167131108236	63	16	38	45	17
HSK-A 63 FMH-K16 100 6.3G 20000 SL SP.S	S10167131148236	63	16	38	100	17
HSK-A 63 FMH-K16 160 6.3G 20000 SL SP.S	S10167131175236	63	16	38	160	17
HSK-A 63 FMH-K22 050 6.3G 20000 SL SP.S	S10167132111236	63	22	48	50	19
HSK-A 63 FMH-K22 100 6.3G 20000 SL SP.S	S10167132148236	63	22	48	100	19
HSK-A 63 FMH-K22 160 6.3G 20000 SL SP.S	S10167132175236	63	22	48	160	19
HSK-A 63 FMH-K27 055 6.3G 20000 SL SP.S	S10167133115236	63	27	58	55	21
HSK-A 63 FMH-K27 100 6.3G 20000 SL SP.S	S10167133148236	63	27	58	100	21
HSK-A 63 FMH-K27 160 6.3G 20000 SL SP.S	S10167133175236	63	27	58	160	21
HSK-A 63 FMH-K32 060 6.3G 20000 SL SP.S	S10167134117236	63	32	78	60	24
HSK-A 63 FMH-K32 100 6.3G 20000 SL SP.S	S10167134148236	63	32	78	100	24
HSK-A 63 FMH-K32 160 6.3G 20000 SL SP.S	S10167134175236	63	32	78	160	24
HSK-A 63 FMH-K40 065 6.3G 20000 SL SP.S	S10167135123236	63	40	88	65	27
HSK-A 63 FMH-K40 100 6.3G 20000 SL SP.S	S10167135148236	63	40	88	100	27
HSK-A 63 FMH-K40 160 6.3G 20000 SL SP.S	S10167135175236	63	40	88	160	27
HSK-A 100 FMH-K16 055 6.3G 20000 SL SP.S	S10168131115236	100	16	38	55	17
HSK-A 100 FMH-K16 100 6.3G 20000 SL SP.S	S10168131148236	100	16	38	100	17
HSK-A 100 FMH-K16 160 6.3G 20000 SL SP.S	S10168131175236	100	16	38	160	17
HSK-A 100 FMH-K22 055 6.3G 20000 SL SP.S	S10168132115236	100	22	48	55	19
HSK-A 100 FMH-K22 100 6.3G 20000 SL SP.S	S10168132148236	100	22	48	100	19
HSK-A 100 FMH-K22 160 6.3G 20000 SL SP.S	S10168132175236	100	22	48	160	19
HSK-A 100 FMH-K27 055 6.3G 20000 SL SP.S	S10168133115236	100	27	58	55	21
HSK-A 100 FMH-K27 100 6.3G 20000 SL SP.S	S10168133148236	100	27	58	100	21
HSK-A 100 FMH-K27 160 6.3G 20000 SL SP.S	S10168133175236	100	27	58	160	21
HSK-A 100 FMH-K32 060 6.3G 20000 SL SP.S	S10168134117236	100	32	78	60	24
HSK-A 100 FMH-K32 100 6.3G 20000 SL SP.S	S10168134148236	100	32	78	100	24
HSK-A 100 FMH-K32 160 6.3G 20000 SL SP.S	S10168134175236	100	32	78	160	24
HSK-A 100 FMH-K40 065 6.3G 20000 SL SP.S	S10168135123236	100	40	88	65	27
HSK-A 100 FMH-K40 100 6.3G 20000 SL SP.S	S10168135148236	100	40	88	100	27

Note: All Dimensions are in mm

**HSK-A (DIN 69893-1)
Boring Bar Blank**

**HSK-A (DIN 69893-1)
Master Mandrell**

Maximum Run out of the External Dia with respect to the External Taper 0.003 mm

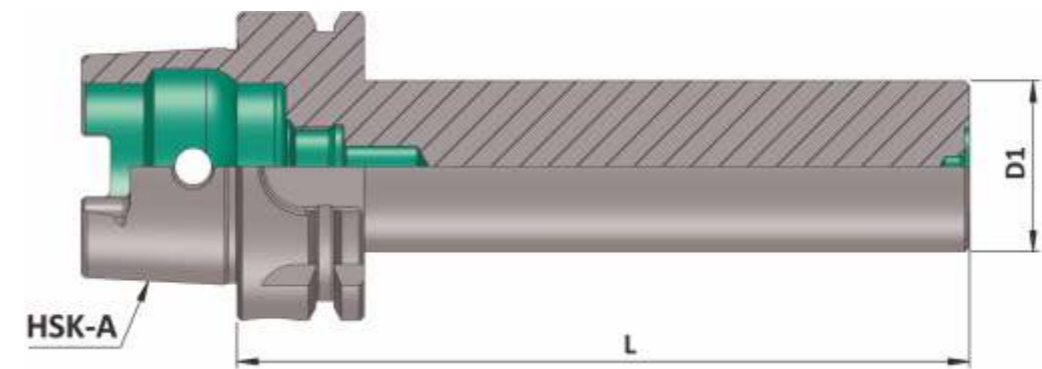
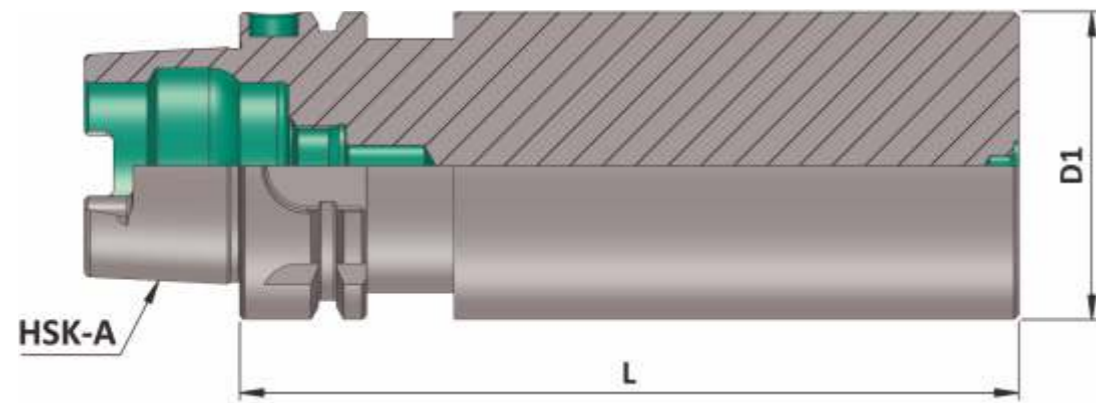

HSK-A (DIN 69893-1) Boring Bar Blank

Item Name	Item Code	HSK-A	D1	L
HSK-A 50 BORING BAR BLANK DIA 52.0 L 200	S10166261237127	50	52	200
HSK-A 50 BORING BAR BLANK DIA 62.0 L 200	S10166262237127	50	62	200
HSK-A 63 BORING BAR BLANK DIA 63.0 L 160	S10167263330127	63	63	160
HSK-A 63 BORING BAR BLANK DIA 63.0 L 250	S10167263256127	63	63	250
HSK-A 63 BORING BAR BLANK DIA 80.0 L 250	S10167264256127	63	80	250
HSK-A 100 BORING BAR BLANK DIA 80.0 L 250	S10168264256127	100	80	250
HSK-A 100 BORING BAR BLANK DIA 80.0 L 275	S10168264501127	100	80	275
HSK-A 100 BORING BAR BLANK DIA 97.0 L 250	S10168265256127	100	97	250

HSK-A (DIN 69893-1) Master Mandrell

(Sub Zero Treated)

Item Name	Item Code	HSK-A	D1	L
HSK-A 50 MASTER MANDRELL DIA32 L 200	S10166164237127	50	32	200
HSK-A 63 MASTER MANDRELL DIA40 L 300	S10167165257127	63	40	300
HSK-A 100 MASTER MANDRELL DIA50 L 300	S10168166257127	100	50	300

Note: All Dimensions are in mm

Note: All Dimensions are in mm

**HSK-A (DIN 69893-1)
NC Drill Chuck (NCDC)**

Maximum Run out on the Mandrell with respect to the External Taper 0.050 mm

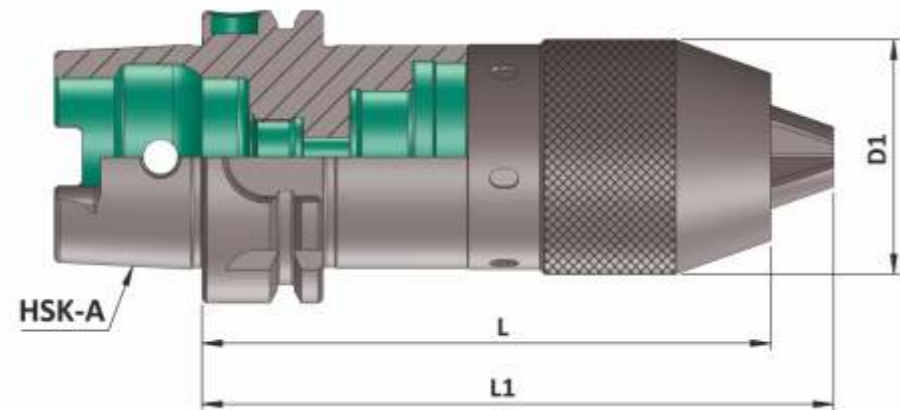

HSK-A (DIN 69893 - 1)
Holders

HSK-A (DIN 69893-1) (NCDC)

Item Name	Item Code	HSK-A	D1	L	L1
HSK-A 50 NCDC 1-13 125	S10166167170209	50	50	125	137.5
HSK-A 63 NCDC 1-13 122.5	S10167167172209	63	50	122.5	135
HSK-A 100 NCDC 1-13 146	S10168167172209	100	50	146	158.5

Accessories:

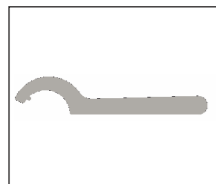

NDCD Spanner
Ref. Page No. 154

Note: All Dimensions are in mm

Die & Mould Chuck (DMC)

◆ **Features :**

- Small outside diameter.
- Best suitable for Die & Mould Industry.
- Most suitable for machining of cavities difficult to reach.
- High precision Runout < 0.005mm (4xd).
- All 'Sigma' Die & Mould Chucks are subjected to Sub-zero treatment (-90° C). This treatment helps to prevent the holders from deformation for many years & hence increases the life.

◆ **Capacity :**

- DMC 06 (3mm to 6mm)
- DMC 08 (3mm to 8 mm)
- DMC 10 (3mm to 10mm)

◆ **Available In Mountings :**

- HSK-A (DIN 69893-1)
- BT (MAS 403) (DIN ISO 7388 - 2)
- BBT (MAS 403)
- SK (DIN 69871) (DIN ISO 7388 - 1)
- Cylindrical Shank

◆ **Balancing :**

- Balanced To 2.5 G 25000 RPM



**HSK-A (DIN-69893-1)
Die & Mould Chuck (DMC)**

Maximum Run out of the Internal Taper with respect to the External Taper < 0.005 mm

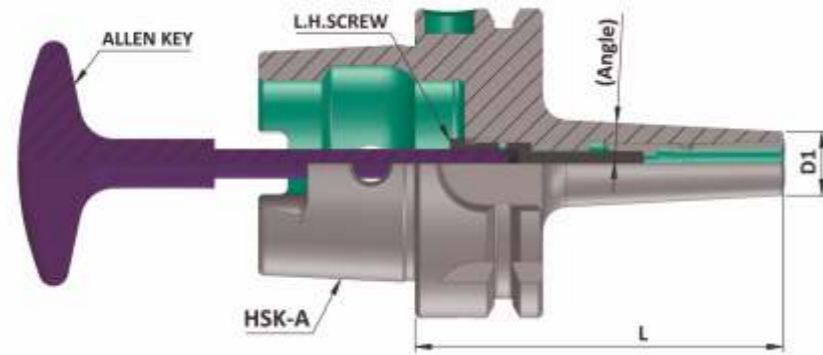

HSK-A (DIN 69893-1) (DMC)

(Balanced to 2.5 G 25000 RPM)

Item Name	Item Code	HSK-A	D1	L	Angle	Screw	Allen Key
HSK-A 50 DMC 06 075 2.5G25000 SL	S10166161127129	50	13	75	3	M5	4X200
HSK-A 63 DMC 06 075 2.5G25000 SL	S10167161127124	63	13	75	3	M5	4X200
HSK-A 63 DMC 06 095 2.5G25000 SL	S10167161145124	63	13	95	3	M5	4X200
HSK-A 63 DMC 06 120 2.5G25000 SL	S10167161162124	63	13	120	3	M5	4X200
HSK-A 63 DMC 06 160 2.5G25000 SL	S10167161175124	63	13	160	3	M5	4X200
HSK-A 63 DMC 08 100 2.5G25000 SL	S10167162148124	63	22	100	3	M6	5X200
HSK-A 63 DMC 08 160 2.5G25000 SL	S10167162175124	63	22	160	3	M6	5X200
HSK-A 63 DMC 10 110 2.5G25000 SL	S10167163156124	63	28	110	3	M8	6X200

Accessories:



DMC Collet
Ref. Page No. 172

Note: All Dimensions are in mm

Power Milling Chuck (PMC)

◆ **Features :**

- 'Sigma' Power Milling Chuck is Very Rigid & Precision.
- It is best for Drilling, Reaming & Milling Operations.
- The tool runs true less than 5 micron on 2D. Hence the tool life increases drastically.
- It's Unibody construction reduces the vibrations, This also helps to increase the tool life.
- All 'Sigma' Die & Mould Chucks are subjected to Sub-zero treatment (-90° C). This treatment helps to prevent the holders from deformation for many years & hence increases the life.

◆ **Available In Mountings :**

- HSK-A (DIN 69893-1)
- BT (MAS 403) (DIN ISO 7388 - 2)
- BBT (MAS 403)
- SK (DIN 69871) (DIN ISO 7388 - 1)

◆ **Balancing :**

- Balanced To 6.3 G 20000 RPM



**HSK-A (DIN 69893-1)
Power Milling Chuck (PMC)**

Maximum Run out of the Internal Dia with respect to the External Taper 0.005 mm

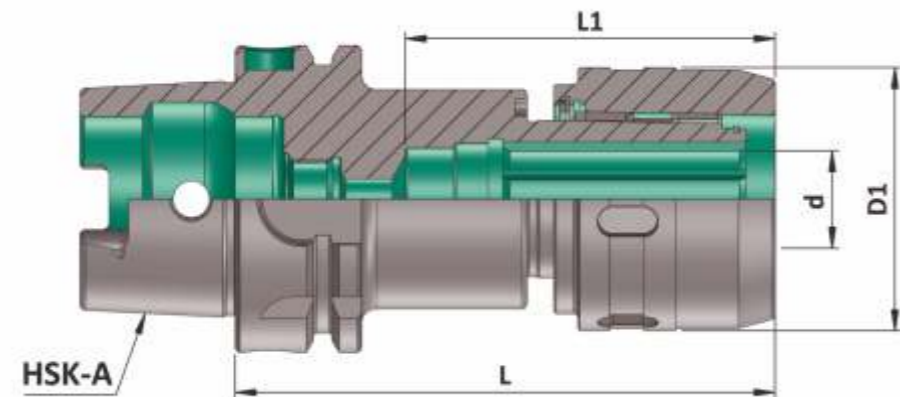

HSK-A (DIN 69893-1) (PMC)

(Balanced to 6.3 G 20000 RPM)

Item Name	Item Code	HSK-A	d	D1	L	L1
HSK-A 50 C20 100 AD/6.3G20000 SL	S10166445148114	50	20	54	100	70
HSK-A 63 C20 105 AD/6.3G20000 SL	S10167445152114	63	20	54	105	70
HSK-A 63 C32 130 AD/6.3G20000 SL	S10167446165114	63	32	72	130	100
HSK-A 100 C20 110 AD/6.3G20000 SL	S10168445156114	100	20	54	110	70
HSK-A 100 C32 135 AD/6.3G20000 SL	S10168446166114	100	32	72	135	100

Accessories:



Reduction Sleeve (RS)
Ref. Page No. 173

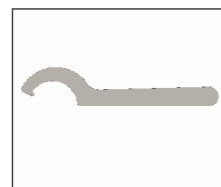

PMC Spanner
Ref. Page No. 154

Note: All Dimensions are in mm

Milling Cutter Arbor (MCA)

◆ **Features :**

- For Mounting of Screw type Modular Milling Cutters.
- Slim Design & hence easy to reach at deep cavities.
- Unibody Construction
- All 'Sigma' Die & Mould Chucks are subjected to Sub-zero treatment (-90° C). This treatment helps to prevent the holders from deformation for many years & hence increases the life.

◆ **Available In Mountings :**

- HSK-A (DIN 69893-1)
- BT (MAS 403) (DIN ISO 7388 - 2)
- BBT (MAS 403)
- SK (DIN 69871) (DIN ISO 7388 - 1)

◆ **Balancing :**

Balanced To 2.5 G 25000 RPM



**HSK-A (DIN 69893-1)
Milling Cutter Arbor (MCA)**

Maximum Run out of the Internal Dia with respect to the External Taper 0.005 mm

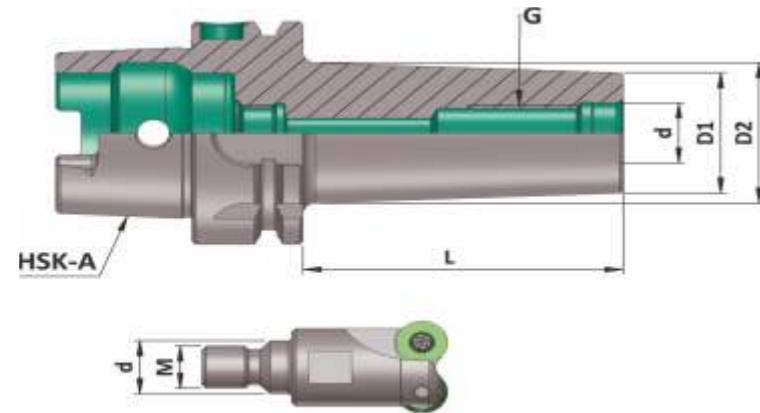

HSK-A (DIN 69893-1)
Holders

HSK-A (DIN 69893-1) (MCA)

**SCREW-TYPE
MODULAR MILLING CUTTER**

(Balanced to 2.5 G 25000 RPM)

Item Name	Item Code	HSK-A	d	D1	D2	G	L
HSK-A 63 MCA06 025 2.5G 25000 SL	S10167137101209	63	6.5	10	13	M6	25
HSK-A 63 MCA08 025 2.5G 25000 SL	S10167138101227	63	8.5	13	15	M8	25
HSK-A 63 MCA08 050 2.5G 25000 SL	S10167138111209	63	8.5	13	23	M8	50
HSK-A 63 MCA08 075 2.5G 25000 SL	S10167138127209	63	8.5	13	23	M8	75
HSK-A 63 MCA08 100 2.5G 25000 SL	S10167138148124	63	8.5	13	23	M8	100
HSK-A 63 MCA10 025 2.5G 25000 SL	S10167139101227	63	10.5	18	20	M10	25
HSK-A 63 MCA10 050 2.5G 25000 SL	S10167139111124	63	10.5	18	23	M10	50
HSK-A 63 MCA10 075 2.5G 25000 SL	S10167139127228	63	10.5	18	28	M10	75
HSK-A 63 MCA10 100 2.5G 25000 SL	S10167139148209	63	10.5	18	32	M10	100
HSK-A 63 MCA10 150 2.5G 25000 SL	S10167139173209	63	10.5	18	36.5	M10	150
HSK-A 63 MCA12 025 2.5G 25000 SL	S10167140101209	63	12.5	21	24	M12	25
HSK-A 63 MCA12 050 2.5G 25000 SL	S10167140111209	63	12.5	21	24	M12	50
HSK-A 63 MCA12 075 2.5G 25000 SL	S10167140127209	63	12.5	21	31	M12	75
HSK-A 63 MCA12 100 2.5G 25000 SL	S10167140148209	63	12.5	21	33	M12	100
HSK-A 63 MCA12 150 2.5G 25000 SL	S10167140173209	63	12.5	21	40	M12	150
HSK-A 63 MCA16 025 2.5G 25000 SL	S10167141101227	63	17	29	29	M16	25
HSK-A 63 MCA16 050 2.5G 25000 SL	S10167141111209	63	17	29	34	M16	50
HSK-A 63 MCA16 075 2.5G 25000 SL	S10167141127209	63	17	29	34	M16	75
HSK-A 63 MCA16 100 2.5G 25000 SL	S10167141148209	63	17	29	36	M16	100
HSK-A 63 MCA16 150 2.5G 25000 SL	S10167141173209	63	17	29	42.5	M16	150
HSK-A 100 MCA08 050 2.5G 25000 SL	S10168138111227	100	8.5	3	23	M8	50
HSK-A 100 MCA10 050 2.5G 25000 SL	S10168139111209	100	10.5	18	23	M10	50
HSK-A 100 MCA10 100 2.5G 25000 SL	S10168139148209	100	10.5	18	32	M10	100
HSK-A 100 MCA10 150 2.5G 25000 SL	S10168139173209	100	10.5	18	36.5	M10	150
HSK-A 100 MCA12 050 2.5G 25000 SL	S10168140111209	100	12.5	21	24	M12	50
HSK-A 100 MCA12 100 2.5G 25000 SL	S10168140148209	100	12.5	21	33	M12	100
HSK-A 100 MCA12 150 2.5G 25000 SL	S10168140173227	100	12.5	21	40	M12	150
HSK-A 100 MCA16 050 2.5G 25000 SL	S10168141111209	100	17	29	34	M16	50
HSK-A 100 MCA16 100 2.5G 25000 SL	S10168141148209	100	17	29	36	M16	100
HSK-A 100 MCA16 150 2.5G 25000 SL	S10168141173209	100	17	29	42.5	M16	150

Note: All Dimensions are in mm

Shrink Fit Holder 4.5 Degree (SFH 4.5°)

◆ **Features :**

- For Mounting Of Carbide Drills, End Mills etc.
- Easy to Reach at Deep Cavities.
- Best T. I. R. & Rigidity during long working life, Result of in house Reasearch & Development & special Heat Treatment.

◆ **Available In Mountings :**

- HSK-A (DIN 69893-1)
- BT (MAS 403) (DIN ISO 7388-2)
- BBT (MAS 403)
- SK (DIN 69871) (DIN ISO 7388-1)

◆ **Balancing :**

- Balanced To 2.5 G 25000 RPM



**HSK-A (DIN 69893-1)
Shrink Fit Holder 4.5 Degree (SFH 4.5°)**

Maximum Run out of the Internal Dia with respect to the External Taper 0.003 mm

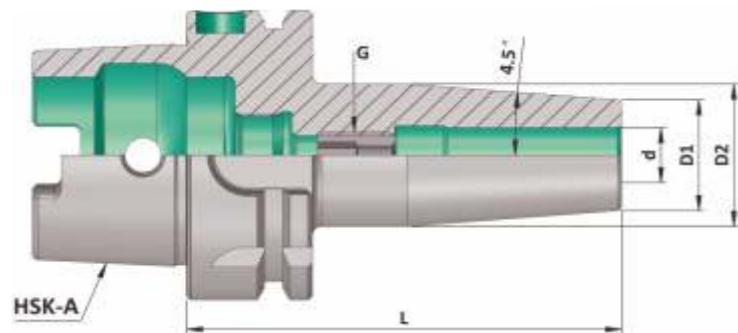

HSK-A (DIN 69893-1) (SFH 4.5°)

(Balanced to 2.5 G 25000 RPM)

Item Name	Item Code	HSK-A	d	D1	D2	G	L
HSK-A 50 SFH03 080 2.5G 25000 SL	S10166274131209	50	3	10	20	-	80
HSK-A 50 SFH03 120 2.5G 25000 SL	S10166274162209	50	3	10	20	-	120
HSK-A 50 SFH03 160 2.5G 25000 SL	S10166274175209	50	3	10	20	-	160
HSK-A 50 SFH04 080 2.5G 25000 SL	S10166275131209	50	4	15	22	-	80
HSK-A 50 SFH04 120 2.5G 25000 SL	S10166275162209	50	4	15	22	-	120
HSK-A 50 SFH04 160 2.5G 25000 SL	S10166275175209	50	4	15	22	-	160
HSK-A 50 SFH05 080 2.5G 25000 SL	S10166276131209	50	5	15	22	-	80
HSK-A 50 SFH05 120 2.5G 25000 SL	S10166276162209	50	5	15	22	-	120
HSK-A 50 SFH05 160 2.5G 25000 SL	S10166276175209	50	5	15	22	-	160
HSK-A 50 SFH06 080 2.5G 25000 SL	S10166277131209	50	6	21	27	M5	80
HSK-A 50 SFH06 120 2.5G 25000 SL	S10166277162209	50	6	21	27	M5	120
HSK-A 50 SFH06 160 2.5G 25000 SL	S10166277175209	50	6	21	27	M5	160
HSK-A 50 SFH08 080 2.5G 25000 SL	S10166285131209	50	8	21	27	M6	80
HSK-A 50 SFH08 120 2.5G 25000 SL	S10166285162209	50	8	21	27	M6	120
HSK-A 50 SFH08 160 2.5G 25000 SL	S10166285175209	50	8	21	27	M6	160
HSK-A 50 SFH10 085 2.5G 25000 SL	S10166279135209	50	10	24	31	M8	85
HSK-A 50 SFH10 120 2.5G 25000 SL	S10166279162209	50	10	24	31	M8	120
HSK-A 50 SFH10 160 2.5G 25000 SL	S10166279175209	50	10	24	31	M8	160
HSK-A 50 SFH12 090 2.5G 25000 SL	S10166280140209	50	12	24	31	M10	90
HSK-A 50 SFH12 120 2.5G 25000 SL	S10166280162209	50	12	24	31	M10	120
HSK-A 50 SFH12 160 2.5G 25000 SL	S10166280175209	50	12	24	31	M10	160
HSK-A 50 SFH14 090 2.5G 25000 SL	S10166284140209	50	14	27	34	M10	90
HSK-A 50 SFH14 120 2.5G 25000 SL	S10166284162209	50	14	27	34	M10	120
HSK-A 50 SFH14 160 2.5G 25000 SL	S10166284175209	50	14	27	34	M10	160
HSK-A 50 SFH16 095 2.5G 25000 SL	S10166281145209	50	16	27	34	M12	95
HSK-A 50 SFH16 120 2.5G 25000 SL	S10166281162209	50	16	27	34	M12	120
HSK-A 50 SFH16 160 2.5G 25000 SL	S10166281175209	50	16	27	34	M12	160
HSK-A 50 SFH18 095 2.5G 25000 SL	S10166282145209	50	18	33	40	M12	95
HSK-A 50 SFH18 120 2.5G 25000 SL	S10166282162209	50	18	33	40	M12	120
HSK-A 50 SFH18 160 2.5G 25000 SL	S10166282175209	50	18	33	40	M12	160
HSK-A 50 SFH20 100 2.5G 25000 SL	S10166283148209	50	20	33	40	M16	100
HSK-A 50 SFH20 120 2.5G 25000 SL	S10166283162209	50	20	33	40	M16	120
HSK-A 50 SFH20 160 2.5G 25000 SL	S10166283175209	50	20	33	40	M16	160

Note: All Dimensions are in mm

**HSK-A (DIN 69893-1)
Shrink Fit Holder 4.5 Degree (SFH 4.5°)**

Maximum Run out of the Internal Dia with respect to the External Taper 0.003 mm

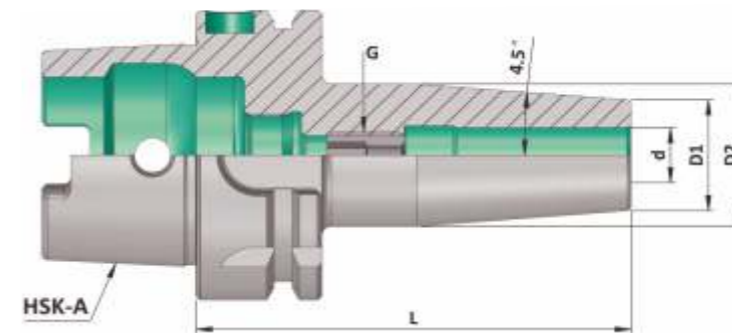

HSK-A (DIN 69893-1) (SFH 4.5°)

(Balanced to 2.5 G 25000 RPM)

Item Name	Item Code	HSK-A	d	D1	D2	G	L
HSK-A 63 SFH03 080 2.5G 25000 SL	S10167274131209	63	3	10	20	-	80
HSK-A 63 SFH03 120 2.5G 25000 SL	S10167274162209	63	3	10	20	-	120
HSK-A 63 SFH03 160 2.5G 25000 SL	S10167274175209	63	3	10	20	-	160
HSK-A 63 SFH04 080 2.5G 25000 SL	S10167275131209	63	4	15	22	-	80
HSK-A 63 SFH04 120 2.5G 25000 SL	S10167275162209	63	4	15	22	-	120
HSK-A 63 SFH04 160 2.5G 25000 SL	S10167275175209	63	4	15	22	-	160
HSK-A 63 SFH05 080 2.5G 25000 SL	S10167276131209	63	5	15	22	-	80
HSK-A 63 SFH05 120 2.5G 25000 SL	S10167276162209	63	5	15	22	-	120
HSK-A 63 SFH05 160 2.5G 25000 SL	S10167276175209	63	5	15	22	-	160
HSK-A 63 SFH06 080 2.5G 25000 SL	S10167277131209	63	6	21	27	M5	80
HSK-A 63 SFH06 120 2.5G 25000 SL	S10167277162209	63	6	21	27	M5	120
HSK-A 63 SFH06 160 2.5G 25000 SL	S10167277175209	63	6	21	27	M5	160
HSK-A 63 SFH08 080 2.5G 25000 SL	S10167285131209	63	8	21	27	M6	80
HSK-A 63 SFH08 120 2.5G 25000 SL	S10167285162209	63	8	21	27	M6	120
HSK-A 63 SFH08 160 2.5G 25000 SL	S10167285175209	63	8	21	27	M6	160
HSK-A 63 SFH10 085 2.5G 25000 SL	S10167279135209	63	10	24	31	M8	85
HSK-A 63 SFH10 120 2.5G 25000 SL	S10167279162209	63	10	24	31	M8	120
HSK-A 63 SFH10 160 2.5G 25000 SL	S10167279175209	63	10	24	31	M8	160
HSK-A 63 SFH12 090 2.5G 25000 SL	S10167280140209	63	12	24	31	M10	90
HSK-A 63 SFH12 120 2.5G 25000 SL	S10167280162209	63	12	24	31	M10	120
HSK-A 63 SFH12 160 2.5G 25000 SL	S10167280175209	63	12	24	31	M10	160
HSK-A 63 SFH14 090 2.5G 25000 SL	S10167284140209	63	14	27	34	M10	90
HSK-A 63 SFH14 120 2.5G 25000 SL	S10167284162209	63	14	27	34	M10	120
HSK-A 63 SFH14 160 2.5G 25000 SL	S10167284175209	63	14	27	34	M10	160
HSK-A 63 SFH16 095 2.5G 25000 SL	S10167281145209	63	16	27	34	M12	95
HSK-A 63 SFH16 120 2.5G 25000 SL	S10167281162209	63	16	27	34	M12	120
HSK-A 63 SFH16 160 2.5G 25000 SL	S10167281175209	63	16	27	34	M12	160
HSK-A 63 SFH18 095 2.5G 25000 SL	S10167282145209	63	18	33	40	M12	95
HSK-A 63 SFH18 120 2.5G 25000 SL	S10167282162209	63	18	33	40	M12	120
HSK-A 63 SFH18 160 2.5G 25000 SL	S10167282175209	63	18	33	40	M12	160
HSK-A 63 SFH20 100 2.5G 25000 SL	S10167283148209	63	20	33	40	M16	100
HSK-A 63 SFH20 120 2.5G 25000 SL	S10167283162209	63	20	33	40	M16	120
HSK-A 63 SFH20 160 2.5G 25000 SL	S10167283175209	63	20	33	40	M16	160

Note: All Dimensions are in mm

HSK-A (DIN 69893-1) Shrink Fit Holder 4.5 Degree (SFH 4.5°)

Maximum Run out of the Internal Dia with respect to the External Taper 0.003 mm

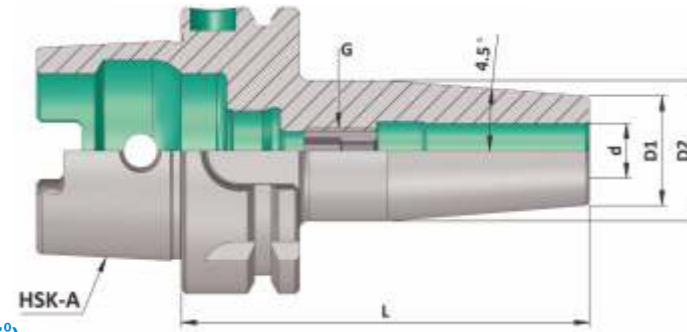

HSK-A (DIN 69893-1) (SFH 4.5°)

(Balanced to 2.5 G 25000 RPM)

Item Name	Item Code	HSK-A	d	D1	D2	G	L
HSK-A 63 SFH25 115 2.5G 25000 SL	S10167287159209	63	25	44	53	M16	115
HSK-A 63 SFH25 120 2.5G 25000 SL	S10167287162209	63	25	44	53	M16	120
HSK-A 63 SFH25 160 2.5G 25000 SL	S10167287175209	63	25	44	53	M16	160
HSK-A 63 SFH32 120 2.5G 25000 SL	S10167288162209	63	32	44	53	M16	120
HSK-A 63 SFH32 160 2.5G 25000 SL	S10167288175209	63	32	44	53	M16	160
HSK-A 100 SFH06 085 2.5G 25000 SL	S10168277135209	100	6	21	27	M5	85
HSK-A 100 SFH06 120 2.5G 25000 SL	S10168277162209	100	6	21	27	M5	120
HSK-A 100 SFH06 160 2.5G 25000 SL	S10168277175209	100	6	21	27	M5	160
HSK-A 100 SFH08 085 2.5G 25000 SL	S10168285135209	100	8	21	27	M6	85
HSK-A 100 SFH08 120 2.5G 25000 SL	S10168285162209	100	8	21	27	M6	120
HSK-A 100 SFH08 160 2.5G 25000 SL	S10168285175209	100	8	21	27	M6	160
HSK-A 100 SFH10 090 2.5G 25000 SL	S10168279140209	100	10	24	31	M8	90
HSK-A 100 SFH10 120 2.5G 25000 SL	S10168279162209	100	10	24	31	M8	120
HSK-A 100 SFH10 160 2.5G 25000 SL	S10168279175209	100	10	24	31	M8	160
HSK-A 100 SFH12 095 2.5G 25000 SL	S10168280145209	100	12	24	31	M10	95
HSK-A 100 SFH12 120 2.5G 25000 SL	S10168280162209	100	12	24	31	M10	120
HSK-A 100 SFH12 160 2.5G 25000 SL	S10168280175209	100	12	24	31	M10	160
HSK-A 100 SFH14 095 2.5G 25000 SL	S10168284145209	100	14	27	34	M10	95
HSK-A 100 SFH14 120 2.5G 25000 SL	S10168284162209	100	14	27	34	M10	120
HSK-A 100 SFH14 160 2.5G 25000 SL	S10168284175209	100	14	27	34	M10	160
HSK-A 100 SFH16 100 2.5G 25000 SL	S10168281148209	100	16	27	34	M12	100
HSK-A 100 SFH16 120 2.5G 25000 SL	S10168281162209	100	16	27	34	M12	120
HSK-A 100 SFH16 160 2.5G 25000 SL	S10168281175209	100	16	27	34	M12	160
HSK-A 100 SFH18 100 2.5G 25000 SL	S10168282148209	100	18	33	40	M12	100
HSK-A 100 SFH18 120 2.5G 25000 SL	S10168282162209	100	18	33	40	M12	120
HSK-A 100 SFH18 160 2.5G 25000 SL	S10168282175209	100	18	33	40	M12	160
HSK-A 100 SFH20 105 2.5G 25000 SL	S10168283152209	100	20	33	40	M16	105
HSK-A 100 SFH20 120 2.5G 25000 SL	S10168283162209	100	20	33	40	M16	120
HSK-A 100 SFH20 160 2.5G 25000 SL	S10168283175209	100	20	33	40	M16	160
HSK-A 100 SFH25 115 2.5G 25000 SL	S10168287159209	100	25	44	53	M16	115
HSK-A 100 SFH25 120 2.5G 25000 SL	S10168287162209	100	25	44	53	M16	120
HSK-A 100 SFH25 160 2.5G 25000 SL	S10168287175209	100	25	44	53	M16	160
HSK-A 100 SFH32 120 2.5G 25000 SL	S10168288162209	100	32	44	53	M16	120
HSK-A 100 SFH32 160 2.5G 25000 SL	S10168288175209	100	32	44	53	M16	160

Note: All Dimensions are in mm

HSK-A (DIN 69893-1) Shrink Fit Holder 4.5° (Face Coolant Channel) (SFH FCC 4.5°)

Maximum Run out of the Internal Dia with respect to the External Taper 0.003 mm

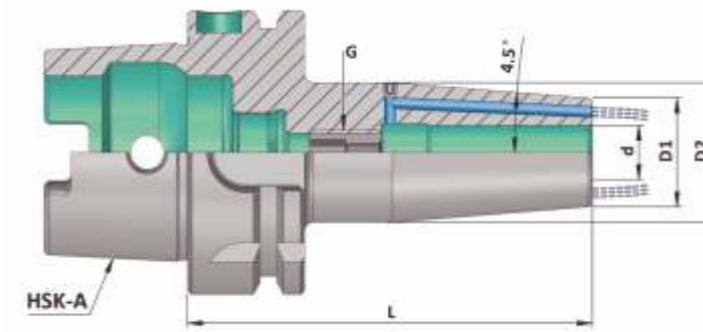

HSK-A (DIN 69893-1) (SFH FCC 4.5°)

(Balanced to 2.5 G 25000 RPM)

Item Name	Item Code	HSK-A	d	D1	D2	G	L
HSK-A 50 SFH03 080 FCC 2.5G 25000 SL	S10166274131256	50	3	10	20	-	80
HSK-A 50 SFH03 120 FCC 2.5G 25000 SL	S10166274162256	50	3	10	20	-	120
HSK-A 50 SFH03 160 FCC 2.5G 25000 SL	S10166274175256	50	3	10	20	-	160
HSK-A 50 SFH04 080 FCC 2.5G 25000 SL	S10166275131256	50	4	15	22	-	80
HSK-A 50 SFH04 120 FCC 2.5G 25000 SL	S10166275162256	50	4	15	22	-	120
HSK-A 50 SFH04 160 FCC 2.5G 25000 SL	S10166275175256	50	4	15	22	-	160
HSK-A 50 SFH05 080 FCC 2.5G 25000 SL	S10166276131256	50	5	15	22	-	80
HSK-A 50 SFH05 120 FCC 2.5G 25000 SL	S10166276162256	50	5	15	22	-	120
HSK-A 50 SFH05 160 FCC 2.5G 25000 SL	S10166276175256	50	5	15	22	-	160
HSK-A 50 SFH06 080 FCC 2.5G 25000 SL	S10166277131256	50	6	21	27	M5	80
HSK-A 50 SFH06 120 FCC 2.5G 25000 SL	S10166277162256	50	6	21	27	M5	120
HSK-A 50 SFH06 160 FCC 2.5G 25000 SL	S10166277175256	50	6	21	27	M5	160
HSK-A 50 SFH08 080 FCC 2.5G 25000 SL	S10166285131256	50	8	21	27	M6	80
HSK-A 50 SFH08 120 FCC 2.5G 25000 SL	S10166285162256	50	8	21	27	M6	120
HSK-A 50 SFH08 160 FCC 2.5G 25000 SL	S10166285175256	50	8	21	27	M6	160
HSK-A 50 SFH10 085 FCC 2.5G 25000 SL	S10166279135256	50	10	24	31	M8	85
HSK-A 50 SFH10 120 FCC 2.5G 25000 SL	S10166279162256	50	10	24	31	M8	120
HSK-A 50 SFH10 160 FCC 2.5G 25000 SL	S10166279175256	50	10	24	31	M8	160
HSK-A 50 SFH12 090 FCC 2.5G 25000 SL	S10166280140256	50	12	24	31	M10	90
HSK-A 50 SFH12 120 FCC 2.5G 25000 SL	S10166280162256	50	12	24	31	M10	120
HSK-A 50 SFH12 160 FCC 2.5G 25000 SL	S10166280175256	50	12	24	31	M10	160
HSK-A 50 SFH14 090 FCC 2.5G 25000 SL	S10166284140256	50	14	27	34	M10	90
HSK-A 50 SFH14 120 FCC 2.5G 25000 SL	S10166284162256	50	14	27	34	M10	120
HSK-A 50 SFH14 160 FCC 2.5G 25000 SL	S10166284175256	50	14	27	34	M10	160
HSK-A 50 SFH16 095 FCC 2.5G 25000 SL	S10166281145256	50	16	27	34	M12	95
HSK-A 50 SFH16 120 FCC 2.5G 25000 SL	S10166281162256	50	16	27	34	M12	120
HSK-A 50 SFH16 160 FCC 2.5G 25000 SL	S10166281175256	50	16	27	34	M12	160
HSK-A 50 SFH18 095 FCC 2.5G 25000 SL	S10166282145256	50	18	33	40	M12	95
HSK-A 50 SFH18 120 FCC 2.5G 25000 SL	S10166282162256	50	18	33	40	M12	120
HSK-A 50 SFH18 160 FCC 2.5G 25000 SL	S10166282175256	50	18	33	40	M12	160
HSK-A 50 SFH20 100 FCC 2.5G 25000 SL	S10166286148256	50	20	33	40	M16	100
HSK-A 50 SFH20 120 FCC 2.5G 25000 SL	S10166286162256	50	20	33	40	M16	120
HSK-A 50 SFH20 160 FCC 2.5G 25000 SL	S10166286175256	50	20	33	40	M16	160

Note: All Dimensions are in mm

**HSK-A (DIN 69893-1)
Shrink Fit Holder 4.5° (Face Coolant Channel)
(SFH FCC 4.5°)**

Maximum Run out of the Internal Dia with respect to the External Taper 0.003 mm

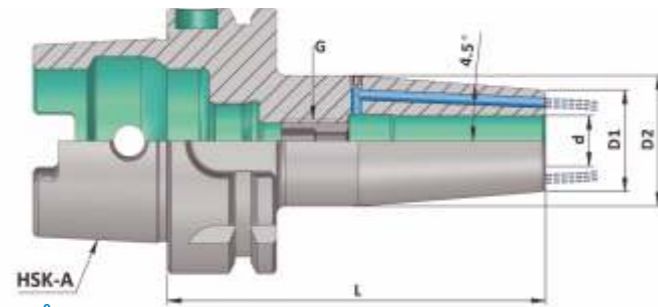

HSK-A (DIN 69893-1) (SFH FCC 4.5°)

(Balanced to 2.5 G 25000 RPM)

Item Name	Item Code	HSK-A	d	D1	D2	G	L
HSK-A 63 SFH03 080 FCC 2.5G 25000 SL	S10167274131256	63	3	10	20	-	80
HSK-A 63 SFH03 120 FCC 2.5G 25000 SL	S10167274162256	63	3	10	20	-	120
HSK-A 63 SFH03 160 FCC 2.5G 25000 SL	S10167274175256	63	3	10	20	-	160
HSK-A 63 SFH04 080 FCC 2.5G 25000 SL	S10167275131256	63	4	15	22	-	80
HSK-A 63 SFH04 120 FCC 2.5G 25000 SL	S10167275162256	63	4	15	22	-	120
HSK-A 63 SFH04 160 FCC 2.5G 25000 SL	S10167275175256	63	4	15	22	-	160
HSK-A 63 SFH05 080 FCC 2.5G 25000 SL	S10167276131256	63	5	15	22	-	80
HSK-A 63 SFH05 120 FCC 2.5G 25000 SL	S10167276162256	63	5	15	22	-	120
HSK-A 63 SFH05 160 FCC 2.5G 25000 SL	S10167276175256	63	5	15	22	-	160
HSK-A 63 SFH06 080 FCC 2.5G 25000 SL	S10167277131256	63	6	21	27	M5	80
HSK-A 63 SFH06 120 FCC 2.5G 25000 SL	S10167277162256	63	6	21	27	M5	120
HSK-A 63 SFH06 160 FCC 2.5G 25000 SL	S10167277175256	63	6	21	27	M5	160
HSK-A 63 SFH08 080 FCC 2.5G 25000 SL	S10167285131256	63	8	21	27	M6	80
HSK-A 63 SFH08 120 FCC 2.5G 25000 SL	S10167285162256	63	8	21	27	M6	120
HSK-A 63 SFH08 160 FCC 2.5G 25000 SL	S10167285175256	63	8	21	27	M6	160
HSK-A 63 SFH10 085 FCC 2.5G 25000 SL	S10167279135256	63	10	24	31	M8	85
HSK-A 63 SFH10 120 FCC 2.5G 25000 SL	S10167279162256	63	10	24	31	M8	120
HSK-A 63 SFH10 160 FCC 2.5G 25000 SL	S10167279175256	63	10	24	31	M8	160
HSK-A 63 SFH12 090 FCC 2.5G 25000 SL	S10167280140256	63	12	24	31	M10	90
HSK-A 63 SFH12 120 FCC 2.5G 25000 SL	S10167280162256	63	12	24	31	M10	120
HSK-A 63 SFH12 160 FCC 2.5G 25000 SL	S10167280175256	63	12	24	31	M10	160
HSK-A 63 SFH14 090 FCC 2.5G 25000 SL	S10167284140256	63	14	27	34	M10	90
HSK-A 63 SFH14 120 FCC 2.5G 25000 SL	S10167284162256	63	14	27	34	M10	120
HSK-A 63 SFH14 160 FCC 2.5G 25000 SL	S10167284175256	63	14	27	34	M10	160
HSK-A 63 SFH16 095 FCC 2.5G 25000 SL	S10167281145256	63	16	27	34	M12	95
HSK-A 63 SFH16 120 FCC 2.5G 25000 SL	S10167281162256	63	16	27	34	M12	120
HSK-A 63 SFH16 160 FCC 2.5G 25000 SL	S10167281175256	63	16	27	34	M12	160
HSK-A 63 SFH18 095 FCC 2.5G 25000 SL	S10167282145256	63	18	33	40	M12	95
HSK-A 63 SFH18 120 FCC 2.5G 25000 SL	S10167282162256	63	18	33	40	M12	120
HSK-A 63 SFH18 160 FCC 2.5G 25000 SL	S10167282175256	63	18	33	40	M12	160
HSK-A 63 SFH20 100 FCC 2.5G 25000 SL	S10167283145256	63	20	33	40	M16	100
HSK-A 63 SFH20 120 FCC 2.5G 25000 SL	S10167283162256	63	20	33	40	M16	120
HSK-A 63 SFH20 160 FCC 2.5G 25000 SL	S10167283175256	63	20	33	40	M16	160
HSK-A 63 SFH25 115 FCC 2.5G 25000 SL	S10167287159256	63	25	44	53	M16	115
HSK-A 63 SFH25 120 FCC 2.5G 25000 SL	S10167287162256	63	25	44	53	M16	120
HSK-A 63 SFH25 160 FCC 2.5G 25000 SL	S10167287175256	63	25	44	53	M16	160
HSK-A 63 SFH32 120 FCC 2.5G 25000 SL	S10167288162256	63	32	44	53	M16	120
HSK-A 63 SFH32 160 FCC 2.5G 25000 SL	S10167288175256	63	32	44	53	M16	160

Note: All Dimensions are in mm

**HSK-A (DIN 69893-1)
Shrink Fit Holder 4.5° (Face Coolant Channel)
(SFH FCC 4.5°)**

Maximum Run out of the Internal Dia with respect to the External Taper 0.003 mm

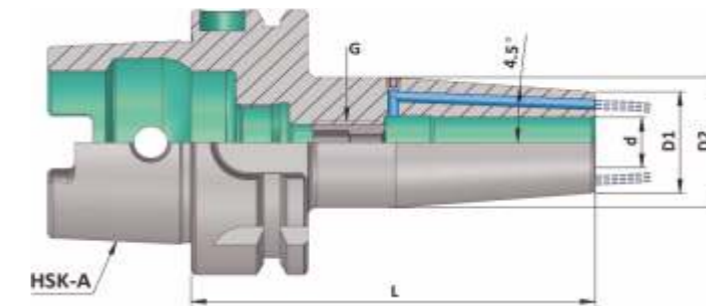

HSK-A (DIN 69893-1) (SFH FCC 4.5°)

(Balanced to 2.5 G 25000 RPM)

Item Name	Item Code	HSK-A	d	D1	D2	G	L
HSK-A 100 SFH06 085 FCC 2.5G 25000 SL	S10168277135256	100	6	21	27	M5	85
HSK-A 100 SFH06 120 FCC 2.5G 25000 SL	S10168277162256	100	6	21	27	M5	120
HSK-A 100 SFH06 160 FCC 2.5G 25000 SL	S10168277175256	100	6	21	27	M5	160
HSK-A 100 SFH08 085 FCC 2.5G 25000 SL	S10168285135256	100	8	21	27	M6	85
HSK-A 100 SFH08 120 FCC 2.5G 25000 SL	S10168285162256	100	8	21	27	M6	120
HSK-A 100 SFH08 160 FCC 2.5G 25000 SL	S10168285175256	100	8	21	27	M6	160
HSK-A 100 SFH10 090 FCC 2.5G 25000 SL	S10168279140256	100	10	24	31	M8	90
HSK-A 100 SFH10 120 FCC 2.5G 25000 SL	S10168279162256	100	10	24	31	M8	120
HSK-A 100 SFH10 160 FCC 2.5G 25000 SL	S10168279175256	100	10	24	31	M8	160
HSK-A 100 SFH12 095 FCC 2.5G 25000 SL	S10168280145256	100	12	24	31	M10	95
HSK-A 100 SFH12 120 FCC 2.5G 25000 SL	S10168280162256	100	12	24	31	M10	120
HSK-A 100 SFH12 160 FCC 2.5G 25000 SL	S10168280175256	100	12	24	31	M10	160
HSK-A 100 SFH14 095 FCC 2.5G 25000 SL	S10168284145256	100	14	27	34	M10	95
HSK-A 100 SFH14 120 FCC 2.5G 25000 SL	S10168284162256	100	14	27	34	M10	120
HSK-A 100 SFH14 160 FCC 2.5G 25000 SL	S10168284175256	100	14	27	34	M10	160
HSK-A 100 SFH16 100 FCC 2.5G 25000 SL	S10168281148256	100	16	27	34	M12	100
HSK-A 100 SFH16 120 FCC 2.5G 25000 SL	S10168281162256	100	16	27	34	M12	120
HSK-A 100 SFH16 160 FCC 2.5G 25000 SL	S10168281175256	100	16	27	34	M12	160
HSK-A 100 SFH18 100 FCC 2.5G 25000 SL	S10168282148256	100	18	33	40	M12	100
HSK-A 100 SFH18 120 FCC 2.5G 25000 SL	S10168282162256	100	18	33	40	M12	120
HSK-A 100 SFH18 160 FCC 2.5G 25000 SL	S10168282175256	100	18	33	40	M12	160
HSK-A 100 SFH20 105 FCC 2.5G 25000 SL	S10168283152256	100	20	33	40	M16	105
HSK-A 100 SFH20 120 FCC 2.5G 25000 SL	S10168283162256	100	20	33	40	M16	120
HSK-A 100 SFH20 160 FCC 2.5G 25000 SL	S10168283175256	100	20	33	40	M16	160
HSK-A 100 SFH25 115 FCC 2.5G 25000 SL	S10168287159256	100	25	44	53	M16	115
HSK-A 100 SFH25 120 FCC 2.5G 25000 SL	S10168287162256	100	25	44	53	M16	120
HSK-A 100 SFH25 160 FCC 2.5G 25000 SL	S10168287175256	100	25	44	53	M16	160
HSK-A 100 SFH32 120 FCC 2.5G 25000 SL	S10168288162256	100	32	44	53	M16	120
HSK-A 100 SFH32 160 FCC 2.5G 25000 SL	S10168288175256	100	32	44	53	M16	160

Note: All Dimensions are in mm

HSK-A (DIN 69893-1)
Shrink Fit Holder Slim 3 Degree (SFH Slim 3°)

Maximum Run out of the Internal Dia with respect to the External Taper 0.003 mm

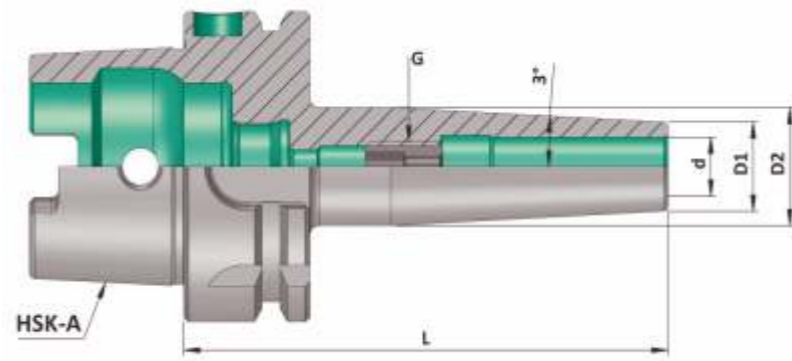

HSK-A (DIN 69893-1) (SFH SLIM 3°)

(Balanced to 2.5 G 25000 RPM)

Item Name	Item Code	HSK-A	d	D1	D2	G	L
HSK-A 63 SFH03 080 SLIM 2.5G 25000 SL	S10305274131258	63	3	9	14	-	80
HSK-A 63 SFH03 120 SLIM 2.5G 25000 SL	S10305274162258	63	3	9	18	-	120
HSK-A 63 SFH03 160 SLIM 2.5G 25000 SL	S10305274175258	63	3	9	19	-	160
HSK-A 63 SFH04 080 SLIM 2.5G 25000 SL	S10305275131258	63	4	10	15	-	80
HSK-A 63 SFH04 120 SLIM 2.5G 25000 SL	S10305275162258	63	4	10	19	-	120
HSK-A 63 SFH04 160 SLIM 2.5G 25000 SL	S10305275175258	63	4	10	23	-	160
HSK-A 63 SFH05 080 SLIM 2.5G 25000 SL	S10305276131258	63	5	11	16	-	80
HSK-A 63 SFH05 120 SLIM 2.5G 25000 SL	S10305276162258	63	5	11	20	-	120
HSK-A 63 SFH05 160 SLIM 2.5G 25000 SL	S10305276175258	63	5	11	24	-	160
HSK-A 63 SFH06 080 SLIM 2.5G 25000 SL	S10305277131258	63	6	12	17	M5	80
HSK-A 63 SFH06 120 SLIM 2.5G 25000 SL	S10305277162258	63	6	12	21	M5	120
HSK-A 63 SFH06 160 SLIM 2.5G 25000 SL	S10305277175258	63	6	12	25	M5	160
HSK-A 63 SFH08 080 SLIM 2.5G 25000 SL	S10305285131258	63	8	14	19	M6	80
HSK-A 63 SFH08 120 SLIM 2.5G 25000 SL	S10305285162258	63	8	14	23	M6	120
HSK-A 63 SFH08 160 SLIM 2.5G 25000 SL	S10305285175258	63	8	14	27	M6	160
HSK-A 63 SFH10 085 SLIM 2.5G 25000 SL	S10305279135258	63	10	16	21.5	M8	85
HSK-A 63 SFH10 120 SLIM 2.5G 25000 SL	S10305279162258	63	10	16	25	M8	120
HSK-A 63 SFH10 160 SLIM 2.5G 25000 SL	S10305279175258	63	10	16	29	M8	160
HSK-A 63 SFH12 090 SLIM 2.5G 25000 SL	S10305280140258	63	12	18	24	M10	90
HSK-A 63 SFH12 120 SLIM 2.5G 25000 SL	S10305280162258	63	12	18	27	M10	120
HSK-A 63 SFH12 160 SLIM 2.5G 25000 SL	S10305280175258	63	12	18	31	M10	160
HSK-A 63 SFH14 090 SLIM 2.5G 25000 SL	S10305284140258	63	14	20	26	M10	90
HSK-A 63 SFH14 120 SLIM 2.5G 25000 SL	S10305284162258	63	14	20	29	M10	120
HSK-A 63 SFH14 160 SLIM 2.5G 25000 SL	S10305284175258	63	14	20	32	M10	160
HSK-A 63 SFH16 095 SLIM 2.5G 25000 SL	S10305281145258	63	16	22	28	M12	95
HSK-A 63 SFH16 120 SLIM 2.5G 25000 SL	S10305281162258	63	16	22	31	M12	120
HSK-A 63 SFH16 160 SLIM 2.5G 25000 SL	S10305281175258	63	16	22	34	M12	160
HSK-A 63 SFH18 095 SLIM 2.5G 25000 SL	S10305282145258	63	18	24	30	M12	95
HSK-A 63 SFH18 120 SLIM 2.5G 25000 SL	S10305282162258	63	18	24	33	M12	120
HSK-A 63 SFH18 160 SLIM 2.5G 25000 SL	S10305282175258	63	18	24	36	M12	160
HSK-A 63 SFH20 100 SLIM 2.5G 25000 SL	S10305283148258	63	20	26	32	M16	100
HSK-A 63 SFH20 120 SLIM 2.5G 25000 SL	S10305283162258	63	20	26	35	M16	120
HSK-A 63 SFH20 160 SLIM 2.5G 25000 SL	S10305283175258	63	20	26	38	M16	160

Note: All Dimensions are in mm

HSK-A (DIN 69893-1)
Shrink Fit Holder Slim 3 Degree (SFH Slim 3°)

Maximum Run out of the Internal Dia with respect to the External Taper 0.003 mm

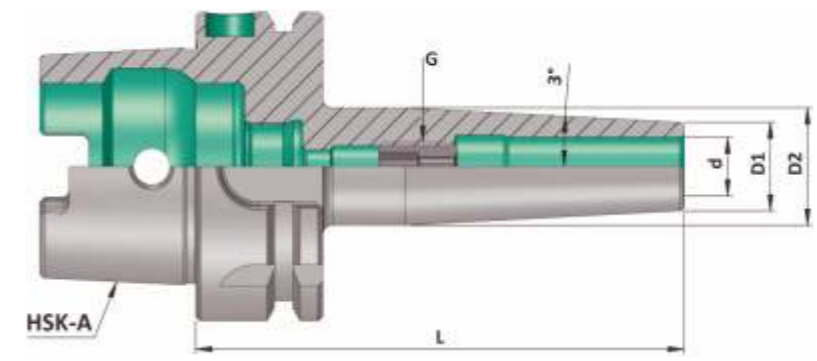

HSK-A (DIN 69893-1) (SFH SLIM 3°)

(Balanced to 2.5 G 25000 RPM)

Item Name	Item Code	HSK-A	d	D1	D2	G	L
HSK-A 100 SFH06 085 SLIM 2.5G 25000 SL	S10168277135258	100	6	12	17	M5	85
HSK-A 100 SFH06 120 SLIM 2.5G 25000 SL	S10168277162258	100	6	12	20.5	M5	120
HSK-A 100 SFH06 160 SLIM 2.5G 25000 SL	S10168277175258	100	6	12	24	M5	160
HSK-A 100 SFH08 085 SLIM 2.5G 25000 SL	S10168285135258	100	8	14	19	M6	85
HSK-A 100 SFH08 120 SLIM 2.5G 25000 SL	S10168285162258	100	8	14	22.5	M6	120
HSK-A 100 SFH08 160 SLIM 2.5G 25000 SL	S10168285175258	100	8	14	27	M6	160
HSK-A 100 SFH10 090 SLIM 2.5G 25000 SL	S10168279140258	100	10	16	21.5	M8	90
HSK-A 100 SFH10 120 SLIM 2.5G 25000 SL	S10168279162258	100	10	16	24.5	M8	120
HSK-A 100 SFH10 160 SLIM 2.5G 25000 SL	S10168279175258	100	10	16	29	M8	160
HSK-A 100 SFH12 095 SLIM 2.5G 25000 SL	S10168280145258	100	12	18	24	M10	95
HSK-A 100 SFH12 120 SLIM 2.5G 25000 SL	S10168280162258	100	12	18	26.5	M10	120
HSK-A 100 SFH12 160 SLIM 2.5G 25000 SL	S10168280175258	100	12	18	31	M10	160
HSK-A 100 SFH14 095 SLIM 2.5G 25000 SL	S10168284145258	100	14	20	26	M10	95
HSK-A 100 SFH14 120 SLIM 2.5G 25000 SL	S10168284162258	100	14	20	29	M10	120
HSK-A 100 SFH14 160 SLIM 2.5G 25000 SL	S10168284175258	100	14	20	32	M10	160
HSK-A 100 SFH16 100 SLIM 2.5G 25000 SL	S10168281148258	100	16	22	29	M12	100
HSK-A 100 SFH16 120 SLIM 2.5G 25000 SL	S10168281162258	100	16	22	31	M12	120
HSK-A 100 SFH16 160 SLIM 2.5G 25000 SL	S10168281175258	100	16	22	35	M12	160
HSK-A 100 SFH18 100 SLIM 2.5G 25000 SL	S10168282148258	100	18	24	30	M12	100
HSK-A 100 SFH18 120 SLIM 2.5G 25000 SL	S10168282162258	100	18	24	33	M12	120
HSK-A 100 SFH18 160 SLIM 2.5G 25000 SL	S10168282175258	100	18	24	36	M12	160
HSK-A 100 SFH20 105 SLIM 2.5G 25000 SL	S10168283148258	100	20	26	32	M16	105
HSK-A 100 SFH20 120 SLIM 2.5G 25000 SL	S10168283162258	100	20	26	35	M16	120
HSK-A 100 SFH20 160 SLIM 2.5G 25000 SL	S10168283175258	100	20	26	38	M16	160

Note: All Dimensions are in mm

**Precision Tool Holder
BT-DIN ISO 7388-2
(MAS 403)**

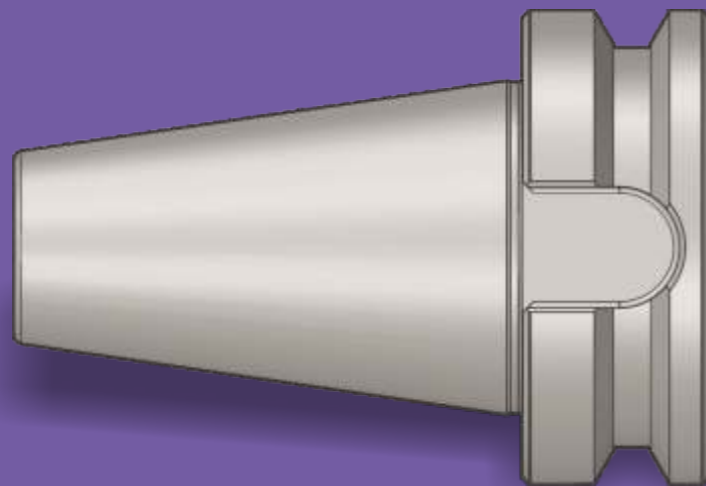

INDEX

Sr. No.	Contents		Page No.
1	Technical Information: BT(MAS 403) DIN ISO 7388 - 2		33
2	Collet Chucks ER (DIN 6499) <ul style="list-style-type: none"> • Collet Chuck ER (AD) DIN ISO 7388 - 2 JD • Collet Chuck ER (AD+B) DIN ISO 7388 - 2 JD/JF • Collet Chuck ER "M" Type (AD+B) DIN ISO 7388 - 2 JD/JF • Collet Chuck ER "A" Type (Short GP) 		34 - 38
3	Weldon Type End Mill Holders (DIN 6359) <ul style="list-style-type: none"> • Weldon (WE) (AD) DIN ISO 7388 - 2 JD 		39 - 41
4	Face Mill Holders (DIN 6357) <ul style="list-style-type: none"> • FMH (AD) DIN ISO 7388 - 2 JD • FMH-K (Through Coolant) (AD+B) DIN ISO 7388 - 2 JD/JF 		42 - 43
5	Boring Bar Blank		44
6	Master Mandrell		45
7	NC Drill Chuck (NCDC)		46
8	Die & Mould Chuck (DMC)		47 - 48
9	Power Milling Chuck (PMC)		49 - 50

INDEX

Sr. No.	Contents		Page No.
10	Shrink Fit Holders 4.5 Degree (SFH 4.5°) <ul style="list-style-type: none"> Shrink Fit Holder (SFH 4.5°) (AD) DIN ISO 7388 - 2 JD Shrink Fit Holder (SFH 4.5°) (AD+B) DIN ISO 7388 - 2 JD/JF 		51 - 56
11	Shrink Fit Holders Slim 3 Degree (SFH Slim 3°) <ul style="list-style-type: none"> Shrink Fit Holder (SFH Slim 3°) (AD) DIN ISO 7388 - 2 JD Shrink Fit Holder (SFH Slim 3°) (AD+B) DIN ISO 7388 - 2 JD/JF 		57 - 59
12	Minimum Length Compensation Tapping Chuck (MLC)		60 - 61

BT (MAS 403) Form A

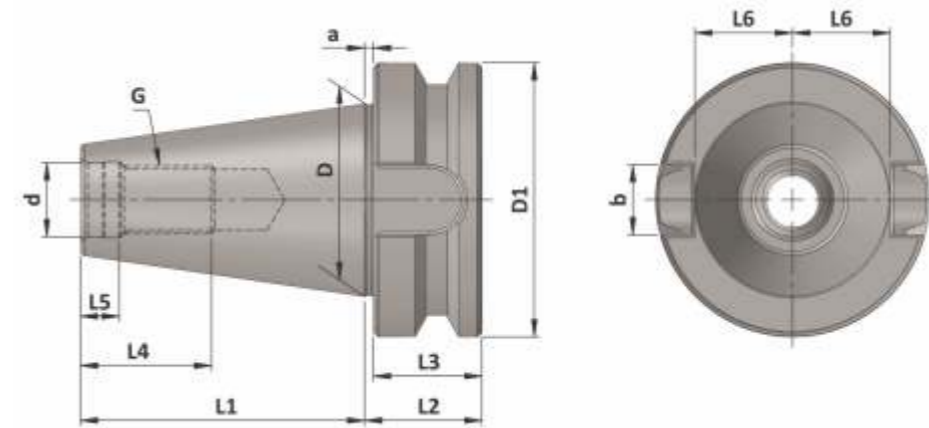

ISO	d	d1	D	D1	a	b	e1	G	L1	L2	L3	L4	L5	L6
30	12.5	-	31.75	46	2	16.1	-	M12	48.4	22	20	24	7.0	16.3
40	17	M4	44.45	63	2	16.1	27	M16	65.4	27	25	32	9.0	22.6
50	25	M6	69.85	100	3	25.7	42	M24	101.8	38	35	47	13.0	35.4

Old Name : BT (MAS 403) Form AD
New Name : BT (MAS 403) DIN ISO7388 - 2 JD
(Coolant Supply Through Center)

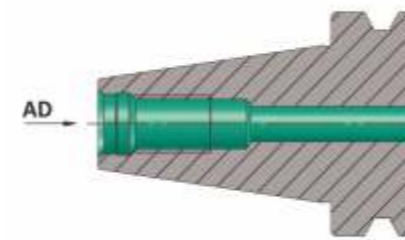

Old Name : BT (MAS 403) Form AD+B
New Name : BT (MAS 403) DIN ISO7388 - 2 JD/JF
(Coolant Supply Through Flange)

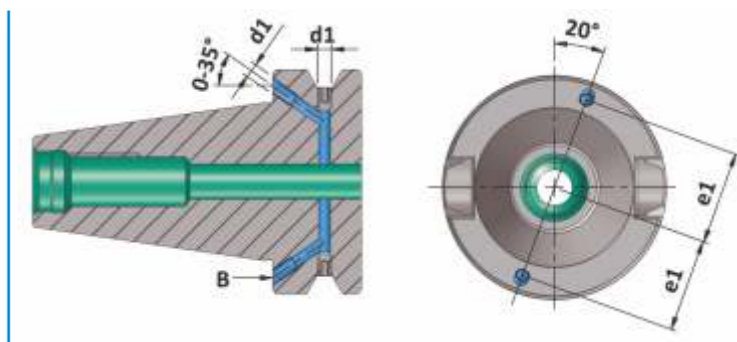

Material :- Case hardened steel, tensile strength in the core min. 950 N/mm²
Execution :- Case hardened to HRC 58 ± 2, Case Depth 0.8 mm., Silver finish.
Accuracy :- 7:24 Taper Angle Class AT 3 As per DIN 2080

Taper Class AT 3 Details

ISO	L	DA-DB	AT 3
30	42	12.280	+0.002
40	59	17.208	+0.003
50	92	26.833	+0.004

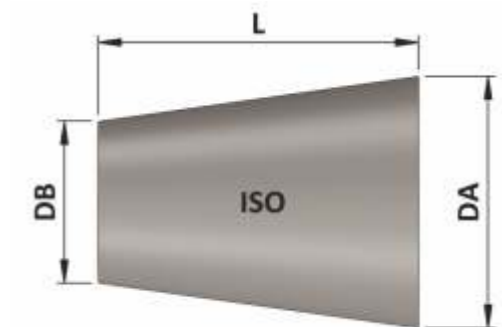

Note: All Dimensions are in mm

**BT (MAS 403) (DIN ISO 7388 - 2) JD
Collet Chuck ER (AD) (DIN 6499)**

Maximum Run out of the Internal Taper with respect to the External Taper 0.005 mm

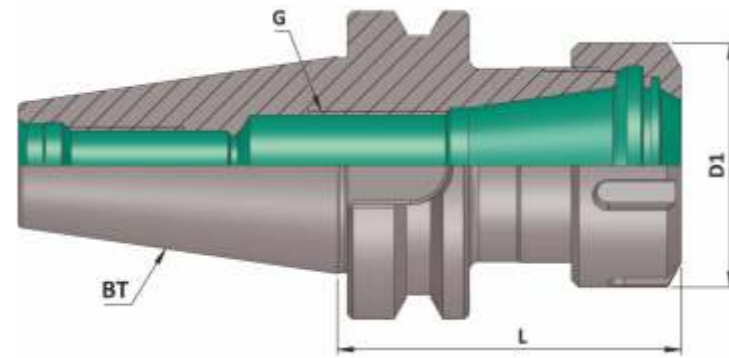

**(Balanced to 6.3 G 15000 RPM) /
(Balanced to 2.5 G 25000 RPM)**

BT (MAS 403) Collet Chuck ER (AD) (JD)

Item Name	Item Code	ISO	Suitable Collet	Collet Capacity	D1	G	L	Nut	Spanner
BT 30 ER 16 060 AD/6.3G15000 SL	S10101149117110	30	ER 16	0.5-10	32	M10X1	60	UM/ER16	E16
BT 30 ER 16 100 AD/6.3G15000 SL	S10101149148110	30	ER 16	0.5-10	32	M10X1	100	UM/ER16	E16
BT 30 ER 20 060 AD/6.3G15000 SL	S10101150117110	30	ER 20	1.0-13	35	M10X1	60	UM/ER20	E20
BT 30 ER 20 100 AD/6.3G15000 SL	S10101150148110	30	ER 20	1.0-13	35	M10X1	100	UM/ER20	E20
BT 30 ER 25 060 AD/6.3G15000 SL	S10101151117110	30	ER 25	1.0-16	42	M18X1	60	UM/ER25	E25
BT 30 ER 25 100 AD/6.3G15000 SL	S10101151148110	30	ER 25	1.0-16	42	M18X1	100	UM/ER25	E25
BT 30 ER 32 060 AD/6.3G15000 SL	S10101152117110	30	ER 32	2.0-20	50	M22X1.5	60	UM/ER32	E32
BT 30 ER 32 100 AD/6.3G15000 SL	S10101152148110	30	ER 32	2.0-20	50	M22X1.5	100	UM/ER32	E32
BT 30 ER 40 080 AD/6.3G15000 SL	S10101153131110	30	ER 40	3.0-26	63	M30X1.5	80	UM/ER40	E40

BT 30 ER 32 050 AD/2.5G25000SL	S10101152111228	30	ER 32	2.0-20	50	M22X1.5	50	UM/ER32	E32
--------------------------------	-----------------	----	-------	--------	----	---------	----	---------	-----

BT 40 ER 16 070 AD/6.3G15000 SL	S10102149125110	40	ER 16	0.5-10	32	M10X1	70	UM/ER16	E16
BT 40 ER 16 100 AD/6.3G15000 SL	S10102149148110	40	ER 16	0.5-10	32	M10X1	100	UM/ER16	E16
BT 40 ER 16 160 AD/6.3G15000 SL	S10102149175110	40	ER 16	0.5-10	32	M10X1	160	UM/ER16	E16
BT 40 ER 20 070 AD/6.3G15000 SL	S10102150125110	40	ER 20	1.0-13	35	M10X1	70	UM/ER20	E20
BT 40 ER 20 100 AD/6.3G15000 SL	S10102150148110	40	ER 20	1.0-13	35	M10X1	100	UM/ER20	E20
BT 40 ER 20 160 AD/6.3G15000 SL	S10102150175110	40	ER 20	1.0-13	35	M10X1	160	UM/ER20	E20
BT 40 ER 25 070 AD/6.3G15000 SL	S10102151125110	40	ER 25	1.0-16	42	M18X1	70	UM/ER25	E25
BT 40 ER 25 100 AD/6.3G15000 SL	S10102151148110	40	ER 25	1.0-16	42	M18X1	100	UM/ER25	E25
BT 40 ER 25 160 AD/6.3G15000 SL	S10102151175110	40	ER 25	1.0-16	42	M18X1	160	UM/ER25	E25
BT 40 ER 32 070 AD/6.3G15000 SL	S10102152125110	40	ER 32	2.0-20	50	M22X1.5	70	UM/ER32	E32
BT 40 ER 32 100 AD/6.3G15000 SL	S10102152148110	40	ER 32	2.0-20	50	M22X1.5	100	UM/ER32	E32
BT 40 ER 32 160 AD/6.3G15000 SL	S10102152175110	40	ER 32	2.0-20	50	M22X1.5	160	UM/ER32	E32
BT 40 ER 40 070 AD/6.3G15000 SL	S10102153125110	40	ER 40	3.0-26	63	M30X1.5	70	UM/ER40	E40
BT 40 ER 40 100 AD/6.3G15000 SL	S10102153148110	40	ER 40	3.0-26	63	M30X1.5	100	UM/ER40	E40
BT 40 ER 40 160 AD/6.3G15000 SL	S10102153175110	40	ER 40	3.0-26	63	M30X1.5	160	UM/ER40	E40
BT 40 ER 50 100 AD/6.3G15000 SL	S10102154148110	40	ER 50	10.0-34	78	M16X2	100	UM/ER50	E50

Note: All Dimensions are in mm

**BT (MAS 403) (DIN ISO 7388 - 2) JD
Collet Chuck ER (AD) (DIN 6499)**

Maximum Run out of the Internal Taper with respect to the External Taper 0.005 mm

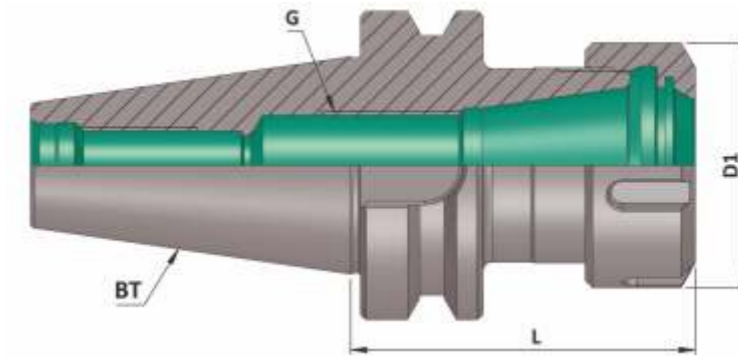

BT (MAS 403) Collet Chuck ER (AD) (JD)

(Balanced to 6.3 G 15000 RPM)

Item Name	Item Code	ISO	Suitable Collet	Collet Capacity	D1	G	L	Nut	Spanner
BT50 ER 16 080 AD/6.3G15000 SL	S10103149131110	50	ER 16	0.5-10	32	M10X1	80	UM/ER16	E16
BT50 ER 16 100 AD/6.3G15000 SL	S10103149148110	50	ER 16	0.5-10	32	M10X1	100	UM/ER16	E16
BT50 ER 16 160 AD/6.3G15000 SL	S10103149175110	50	ER 16	0.5-10	32	M10X1	160	UM/ER16	E16
BT50 ER 20 100 AD/6.3G15000 SL	S10103150148110	50	ER 20	1.0-13	35	M10X1	100	UM/ER20	E20
BT50 ER 20 160 AD/6.3G15000 SL	S10103150175110	50	ER 20	1.0-13	35	M10X1	160	UM/ER20	E20
BT50 ER 25 080 AD/6.3G15000 SL	S10103151131110	50	ER 25	1.0-16	42	M18X1	80	UM/ER25	E25
BT50 ER 25 100 AD/6.3G15000 SL	S10103151148110	50	ER 25	1.0-16	42	M18X1	100	UM/ER25	E25
BT50 ER 25 160 AD/6.3G15000 SL	S10103151175110	50	ER 25	1.0-16	42	M18X1	160	UM/ER25	E25
BT50 ER 32 080 AD/6.3G15000 SL	S10103152131110	50	ER 32	2.0-20	50	M22X1.5	80	UM/ER32	E32
BT50 ER 32 100 AD/6.3G15000 SL	S10103152148110	50	ER 32	2.0-20	50	M22X1.5	100	UM/ER32	E32
BT50 ER 32 160 AD/6.3G15000 SL	S10103152175110	50	ER 32	2.0-20	50	M22X1.5	160	UM/ER32	E32
BT50 ER 40 080 AD/6.3G15000 SL	S10103153131110	50	ER 40	3.0-26	63	M30X1.5	80	UM/ER40	E40
BT50 ER 40 100 AD/6.3G15000 SL	S10103153148110	50	ER 40	3.0-26	63	M30X1.5	100	UM/ER40	E40
BT50 ER 40 160 AD/6.3G15000 SL	S10103153175110	50	ER 40	3.0-26	63	M30X1.5	160	UM/ER40	E40
BT50 ER 50 100 AD/6.3G15000 SL	S10103154148110	50	ER 50	10.0-34	78	M16X2	100	UM/ER50	E50
BT50 ER 50 160 AD/6.3G15000 SL	S10103154175110	50	ER 50	10.0-34	78	M16X2	160	UM/ER50	E50

Accessories:

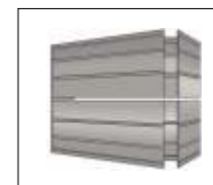

Collet ER (DIN 6499)
Ref. Page No. 164-168



Q.C.Tap Collet QCTC
Ref. Page No. 174-182



ER Nut
Ref. Page No. 151-152



ER Spanner
Ref. Page No. 153

Note: All Dimensions are in mm

**BT (MAS 403) (DIN ISO 7388 - 2) JD/JF
Collet Chuck ER (AD+B) (DIN 6499)**

Maximum Run out of the Internal Taper with respect to the External Taper 0.005 mm

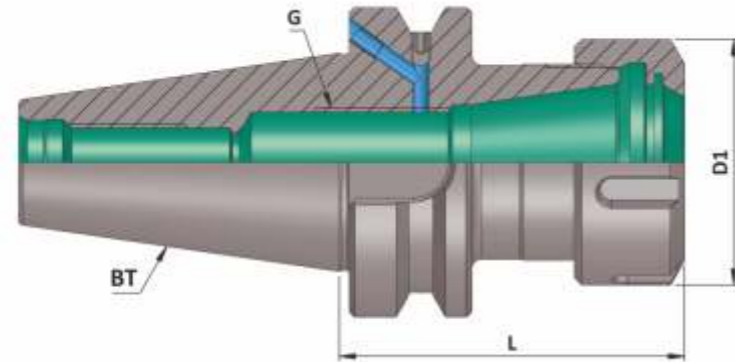

BT (MAS 403)
DIN ISO 7388 - 2 Holders

BT (MAS 403) Collet Chuck ER (AD+B) (JD/JF)

(Balanced to 6.3 G 15000 RPM)

Item Name	Item Code	ISO	Suitable Collet	Collet Capacity	D1	G	L	Nut	Spanner
BT40 ER 16 070 AD+B/6.3G15000SL	S10102149125112	40	ER 16	0.5-10	32	M10X1	70	UM/ER16	E16
BT40 ER 16 100 AD+B/6.3G15000SL	S10102149148112	40	ER 16	0.5-10	32	M10X1	100	UM/ER16	E16
BT40 ER 16 160 AD+B/6.3G15000SL	S10102149175112	40	ER 16	0.5-10	32	M10X1	160	UM/ER16	E16
BT40 ER 20 070 AD+B/6.3G15000 SL	S10102150125112	40	ER 20	1.0-13	35	M10X1	70	UM/ER20	E20
BT40 ER 20 100 AD+B/6.3G15000 SL	S10102150148112	40	ER 20	1.0-13	35	M10X1	100	UM/ER20	E20
BT40 ER 20 160 AD+B/6.3G15000 SL	S10102150175112	40	ER 20	1.0-13	35	M10X1	160	UM/ER20	E20
BT40 ER 25 070 AD+B/6.3G15000 SL	S10102151125112	40	ER 25	1.0-16	42	M18X1	70	UM/ER25	E25
BT40 ER 25 100 AD+B/6.3G15000 SL	S10102151148112	40	ER 25	1.0-16	42	M18X1	100	UM/ER25	E25
BT40 ER 25 160 AD+B/6.3G15000 SL	S10102151175112	40	ER 25	1.0-16	42	M18X1	160	UM/ER25	E25
BT40 ER 32 070 AD+B/6.3G15000 SL	S10102152125112	40	ER 32	2.0-20	50	M22X1.5	70	UM/ER32	E32
BT40 ER 32 100 AD+B/6.3G15000 SL	S10102152148112	40	ER 32	2.0-20	50	M22X1.5	100	UM/ER32	E32
BT40 ER 32 160 AD+B/6.3G15000 SL	S10102152175112	40	ER 32	2.0-20	50	M22X1.5	160	UM/ER32	E32
BT40 ER 40 070 AD+B/6.3G15000 SL	S10102153125112	40	ER 40	3.0-26	63	M30X1.5	70	UM/ER40	E40
BT40 ER 40 100 AD+B/6.3G15000 SL	S10102153148112	40	ER 40	3.0-26	63	M30X1.5	100	UM/ER40	E40
BT40 ER 40 160 AD+B/6.3G15000 SL	S10102153175112	40	ER 40	3.0-26	63	M30X1.5	160	UM/ER40	E40
BT40 ER 50 100 AD+B/6.3G15000 SL	S10102154148112	40	ER 50	10.0-34	78	M16X2	100	UM/ER50	E50

BT 50 ER 16 080 AD+B/6.3G 15000 SL	S10103149131233	50	ER 16	0.5-10	32	M10X1	80	UM/ER16	E16
BT 50 ER 16 100 AD+B/6.3G 15000 SL	S10103149148112	50	ER 16	0.5-10	32	M10X1	100	UM/ER16	E16
BT 50 ER 16 160 AD+B/6.3G 15000 SL	S10103149175112	50	ER 16	0.5-10	32	M10X1	160	UM/ER16	E16
BT 50 ER 25 080 AD+B/6.3G 15000 SL	S10103151131112	50	ER 25	1.0-16	42	M18X1	80	UM/ER25	E25
BT 50 ER 25 100 AD+B/6.3G 15000 SL	S10103151148112	50	ER 25	1.0-16	42	M18X1	100	UM/ER25	E25
BT 50 ER 25 160 AD+B/6.3G 15000 SL	S10103151175112	50	ER 25	1.0-16	42	M18X1	160	UM/ER25	E25
BT 50 ER 32 080 AD+B/6.3G 15000 SL	S10103152131112	50	ER 32	2.0-20	50	M22X1.5	80	UM/ER32	E32
BT 50 ER 32 100 AD+B/6.3G 15000 SL	S10103152148112	50	ER 32	2.0-20	50	M22X1.5	100	UM/ER32	E32
BT 50 ER 32 160 AD+B/6.3G 15000 SL	S10103152175112	50	ER 32	2.0-20	50	M22X1.5	160	UM/ER32	E32
BT 50 ER 40 080 AD+B/6.3G 15000 SL	S10103153131112	50	ER 40	3.0-26	63	M30X1.5	80	UM/ER40	E40
BT 50 ER 40 100 AD+B/6.3G 15000 SL	S10103153148112	50	ER 40	3.0-26	63	M30X1.5	100	UM/ER40	E40
BT 50 ER 40 160 AD+B/6.3G 15000 SL	S10103153175112	50	ER 40	3.0-26	63	M30X1.5	160	UM/ER40	E40
BT 50 ER 50 100 AD+B/6.3G 15000 SL	S10103154148112	50	ER 50	10.0-34	78	M16X2	100	UM/ER50	E50
BT 50 ER 50 160 AD+B/6.3G 15000 SL	S10103154175112	50	ER 50	10.0-34	78	M16X2	160	UM/ER50	E50

Note: All Dimensions are in mm

**BT (MAS 403) (DIN ISO 7388 - 2) JD/JF
Collet Chuck ER-M Type (AD+B) (DIN 6499)**

Maximum Run out of the Internal Taper with respect to the External Taper 0.005 mm

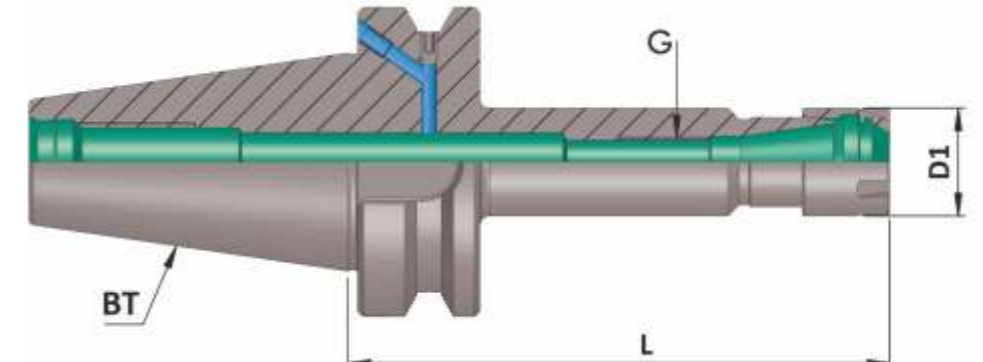

BT (MAS 403)
DIN ISO 7388 - 2 Holders

BT (MAS 403) Collet Chuck ER-M Type (AD+B) (JD/JF)

(Balanced to 2.5 G 25000 RPM)

Item Name	Item Code	ISO	Suitable Collet	Collet Capacity	D1	G	L	Nut	Spanner
BT 40 ER11M 070 AD+B/2.5G 25000 SL	S10102156125230	40	ER 11	0.5-7	16	M6X1	70	ER11M	E11M
BT 40 ER11M 100 AD+B/2.5G 25000 SL	S10102156148230	40	ER 11	0.5-7	16	M6X1	100	ER11M	E11M
BT 40 ER11M 160 AD+B/2.5G 25000 SL	S10102156175230	40	ER 11	0.5-7	16	M6X1	160	ER11M	E11M
BT 40 ER16M 070 AD+B/2.5G 25000 SL	S10102157125230	40	ER 16	0.5-10	22	M10X1	70	ER16M	E16M
BT 40 ER16M 100 AD+B/2.5G 25000 SL	S10102157148230	40	ER 16	0.5-10	22	M10X1	100	ER16M	E16M
BT 40 ER16M 120 AD+B/2.5G 25000 SL	S10102157162112	40	ER 16	0.5-10	22	M10X1	120	ER16M	E16M
BT 40 ER16M 160 AD+B/2.5G 25000 SL	S10102157175112	40	ER 16	0.5-10	22	M10X1	160	ER16M	E16M
BT 40 ER20M 120 AD+B/2.5G 25000 SL	S10102158162112	40	ER 20	1.0-13	28	M10X1	120	ER20M	E20M
BT 40 ER20M 160 AD+B/2.5G 25000 SL	S10102158175112	40	ER 20	1.0-13	28	M10X1	160	ER20M	E20M
BT 40 ER25M 070 AD+B/2.5G 25000 SL	S10102159125230	40	ER 25	1.0-16	35	M18X1	70	ER25M	E25M
BT 40 ER25M 100 AD+B/2.5G 25000 SL	S10102159148230	40	ER 25	1.0-16	35	M18X1	100	ER25M	E25M
BT 40 ER25M 120 AD+B/2.5G 25000 SL	S10102159162112	40	ER 25	1.0-16	35	M18X1	120	ER25M	E25M
BT 40 ER25M 160 AD+B/2.5G 25000 SL	S10102159175112	40	ER 25	1.0-16	35	M18X1	160	ER25M	E25M

Accessories:

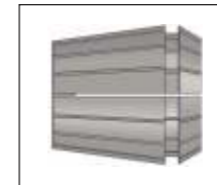

Collet ER (DIN 6499)
Ref. Page No. 164-168



Tap Collet ER-G
Ref. Page No. 169-171



Q.C.Tap Collet QCTC
Ref. Page No. 174-182



ER Nut & ER Sealed Nut & ER M Nut
Ref. Page No. 151-152 & 155-156



Sealing Disc
Ref. Page No. 157-162



ER Spanner
Ref. Page No. 153

Note: All Dimensions are in mm

**BT (MAS 403) (DIN ISO 7388 - 2)
Short GP Collet Chuck ER-A**

Maximum Run out of the Internal Taper with respect to the External Taper 0.005 mm

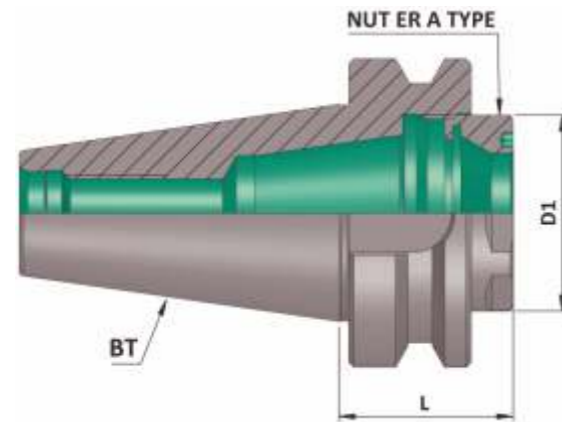

**(Balanced to 2.5 G 25000 RPM) /
(Balanced to 6.3 G 15000 RPM)**

BT (MAS 403) Short Length Collet Chuck ER - A

Item Name	Item Code	ISO	Suitable Collet	Collet Capacity	D1	L	Suitable Nut
BT 30 ER 25A 027AD/2.5G 25000 SL	S10101151500228	30	ER 25	1-16	32	27	ER25A
BT 40 ER 32A 32 AD/6.3G 15000 SL	S10102244248110	40	ER 32	2-20	40	32	ER32A
BT 50 ER 32A 43 AD/6.3G 15000 SL	S10103244249110	50	ER 32	2-20	40	43	ER32A

Accessories:



Collet ER (DIN 6499)
Ref. Page No. 164-168



Tap Collet ER-G
Ref. Page No. 169-171



Q.C. Tap Collet QCTC
Ref. Page No. 174-182



ER A Nut
Ref. Page No. 151-152

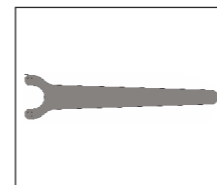

ER A Type Spanner
Ref. Page No. 153

Note: All Dimensions are in mm

**BT (MAS 403) (DIN ISO 7388 - 2) JD
Weldon Type End Mill Holder (DIN 6359) (WE) (AD)**

Maximum Run out of the Internal Dia with respect to the External Taper 0.005 mm

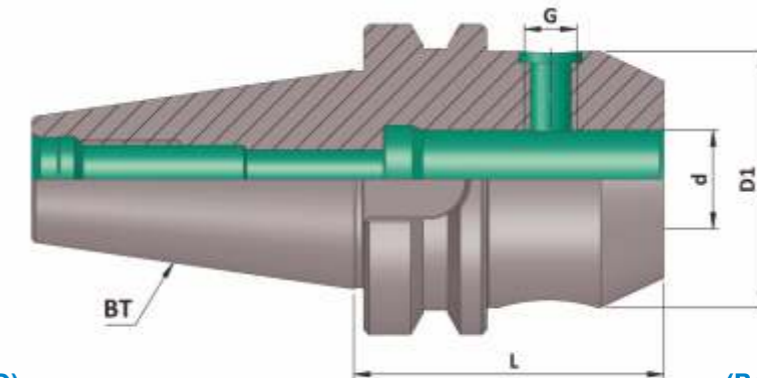

BT (MAS 403) (WE) (AD) (JD)

(Balanced to 6.3 G 15000 RPM)

Item Name	Item Code	ISO	d	D1	G	L	Screw Qty.
BT 30 WE06 050 AD/6.3G 15000SL	S101011111111110	30	6	25	M6	50	1
BT 30 WE08 050 AD/6.3G 15000 SL	S101011121111110	30	8	28	M8	50	1
BT 30 WE10 050 AD/6.3G 15000 SL	S101011131111110	30	10	35	M10	50	1
BT 30 WE12 055 AD/6.3G 15000 SL	S101011141115110	30	12	42	M12	55	1
BT 30 WE14 055 AD/6.3G 15000 SL	S10101258115110	30	14	44	M12	55	1
BT 30 WE16 063 AD/6.3G 15000 SL	S10101115119110	30	16	48	M14	63	1
BT 30WE18 063 AD/6.3G 15000 SL	S10101259119110	30	18	50	M14	63	1
BT 30WE20 070 AD/6.3G 15000 SL	S10101116125110	30	20	52	M16	70	1

BT 40WE06 050 AD/6.3G 15000 SL	S10102111111110	40	6	25	M6	50	1
BT 40WE06 100 AD/6.3G 15000 SL	S10102111148110	40	6	25	M6	100	1
BT 40WE06 160 AD/6.3G 15000 SL	S10102111175110	40	6	25	M6	160	1
BT 40WE 08 050 AD/6.3G 15000 SL	S10102112111110	40	8	28	M8	50	1
BT 40WE 08 100 AD/6.3G 15000 SL	S10102112148110	40	8	28	M8	100	1
BT 40WE 08 160 AD/6.3G 15000 SL	S10102112175110	40	8	28	M8	160	1
BT 40WE 10 063 AD/6.3G 15000 SL	S10102113119110	40	10	35	M10	63	1
BT 40WE 10 100 AD/6.3G 15000 SL	S10102113148110	40	10	35	M10	100	1
BT 40WE 10 160 AD/6.3G 15000 SL	S10102113175110	40	10	35	M10	160	1
BT 40WE 12 063 AD/6.3G 15000 SL	S10102114119110	40	12	42	M12	63	1
BT 40WE 12 100 AD/6.3G 15000 SL	S10102114148110	40	12	42	M12	100	1
BT 40WE 12 160 AD/6.3G 15000 SL	S10102114175110	40	12	42	M12	160	1
BT 40WE 14 063 AD/6.3G 15000 SL	S10102258119110	40	14	44	M12	63	1
BT 40WE 14 100 AD/6.3G 15000 SL	S10102258148110	40	14	44	M12	100	1
BT 40WE 14 160 AD/6.3G 15000 SL	S10102258175110	40	14	44	M12	160	1
BT 40WE 16 063 AD/6.3G 15000 SL	S10102115119110	40	16	48	M14	63	1
BT 40WE 16 100 AD/6.3G 15000 SL	S10102115148110	40	16	48	M14	100	1
BT 40WE 16 160 AD/6.3G 15000 SL	S10102115175110	40	16	48	M14	160	1
BT 40WE 18 063 AD/6.3G 15000 SL	S10102259119110	40	18	50	M14	63	1
BT 40WE 18 100 AD/6.3G 15000 SL	S10102259148110	40	18	50	M14	100	1
BT 40WE 18 160 AD/6.3G 15000 SL	S10102259175110	40	18	50	M14	160	1
BT 40WE 20 063 AD/6.3G 15000 SL	S10102116119110	40	20	52	M16	63	1
BT 40WE 20 100 AD/6.3G 15000 SL	S10102116148110	40	20	52	M16	100	1
BT 40WE 20 160 AD/6.3G 15000 SL	S10102116175110	40	20	52	M16	160	1

Note: • All Dimensions are in mm
• These Holders are most suitable for Weldon Type End Mill as per standard DIN 1835 - B

Continued...

BT (MAS 403) (DIN ISO 7388 - 2) JD
Weldon Type End Mill Holder (DIN 6359) (WE) (AD)

Maximum Run out of the Internal Dia with respect to the External Taper 0.005 mm

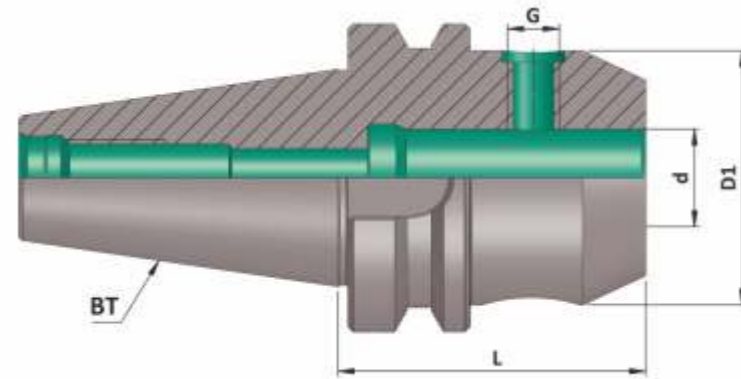

BT (MAS 403) (WE) (AD) (JD)

(Balanced to 6.3 G 15000 RPM)

Item Name	Item Code	ISO	d	D1	G	L	Screw Qty.
BT 40 WE 25 090 AD/6.3G15000 SL	S10102117140110	40	25	65	M18X2	90	2
BT 40 WE 25 160 AD/6.3G15000 SL	S10102117175110	40	25	65	M18X2	160	2
BT 40 WE 32 100 AD/6.3G15000 SL	S10102118148110	40	32	72	M20X2	100	2
BT 40 WE 32 160 AD/6.3G15000 SL	S10102118175110	40	32	72	M20X2	160	2
BT 40 WE 40 105 AD/6.3G15000 SL	S10102119152110	40	40	80	M20X2	105	2
BT 40 WE 40 160 AD/6.3G15000 SL	S10102119175110	40	40	80	M20X2	160	2

BT 50 WE 06 063 AD/6.3G15000 SL	S10103111119110	50	6	25	M6	63	1
BT 50 WE 06 100 AD/6.3G15000 SL	S10103111148110	50	6	25	M6	100	1
BT 50 WE 06 160 AD/6.3G15000 SL	S10103111175110	50	6	25	M6	160	1
BT 50 WE 08 063 AD/6.3G15000 SL	S10103112119110	50	8	28	M8	63	1
BT 50 WE 08 100 AD/6.3G15000 SL	S10103112148110	50	8	28	M8	100	1
BT 50 WE 08 160 AD/6.3G15000 SL	S10103112175110	50	8	28	M8	160	1
BT 50 WE 10 080 AD/6.3G15000 SL	S10103113125110	50	10	35	M10	80	1
BT 50 WE 10 100 AD/6.3G15000 SL	S10103113148110	50	10	35	M10	100	1
BT 50 WE 10 160 AD/6.3G15000 SL	S10103113175110	50	10	35	M10	160	1
BT 50 WE 12 080 AD/6.3G15000 SL	S10103114131110	50	12	42	M12	80	1
BT 50 WE 12 100 AD/6.3G15000 SL	S10103114148110	50	12	42	M12	100	1
BT 50 WE 12 160 AD/6.3G15000 SL	S10103114175110	50	12	42	M12	160	1
BT 50 WE 14 080 AD/6.3G15000 SL	S10103258131110	50	14	44	M12	80	1
BT 50 WE 14 100 AD/6.3G15000 SL	S10103258148110	50	14	44	M12	100	1
BT 50 WE 14 160 AD/6.3G15000 SL	S10103258175110	50	14	44	M12	160	1
BT 50 WE 16 080 AD/6.3G15000 SL	S10103115131110	50	16	48	M14	80	1
BT 50 WE 16 100 AD/6.3G15000 SL	S10103115148110	50	16	48	M14	100	1
BT 50 WE 16 160 AD/6.3G15000 SL	S10103115175110	50	16	48	M14	160	1
BT 50 WE 18 080 AD/6.3G15000 SL	S10103259131110	50	18	50	M14	80	1
BT 50 WE 18 100 AD/6.3G15000 SL	S10103259148110	50	18	50	M14	100	1
BT 50 WE 18 160 AD/6.3G15000 SL	S10103259175110	50	18	50	M14	160	1
BT 50 WE 20 080 AD/6.3G15000 SL	S10103116131110	50	20	52	M16	80	1
BT 50 WE 20 100 AD/6.3G15000 SL	S10103116148110	50	20	52	M16	100	1
BT 50 WE 20 160 AD/6.3G15000 SL	S10103116175110	50	20	52	M16	160	1

Note: • All Dimensions are in mm
 • These Holders are most suitable for Weldon Type End Mill as per standard DIN 1835 - B

BT (MAS 403) (DIN ISO 7388 - 2) JD
Weldon Type End Mill Holder (DIN 6359) (WE) (AD)

Maximum Run out of the Internal Dia with respect to the External Taper 0.005 mm

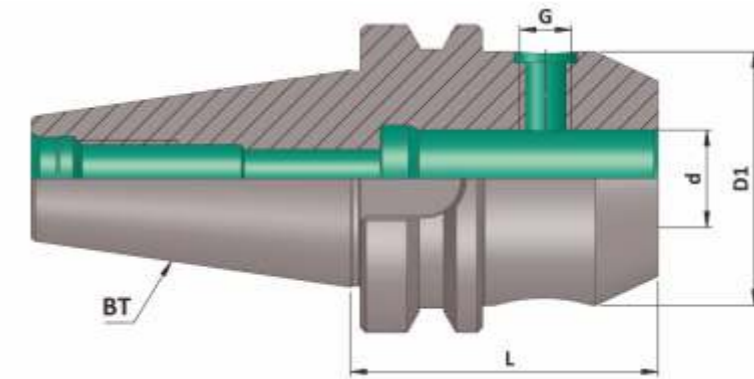

BT (MAS 403) (WE) (AD) (JD)

(Balanced to 6.3 G 15000 RPM)

Item Name	Item Code	ISO	d	D1	G	L	Screw Qty.
BT 50 WE 25 100 AD/6.3G 15000 SL	S10103117148110	50	25	65	M18X2	100	2
BT 50 WE 25 160 AD/6.3G 15000 SL	S10103117175110	50	25	65	M18X2	160	2
BT 50 WE 32 105 AD/6.3G 15000 SL	S10103118152110	50	32	72	M20X2	105	2
BT 50 WE 32 160 AD/6.3G 15000 SL	S10103118175110	50	32	72	M20X2	160	2
BT 50 WE 40 115 AD/6.3G 15000 SL	S10103119159110	50	40	80	M20X2	115	2
BT 50 WE 40 160 AD/6.3G 15000 SL	S10103119175110	50	40	80	M20X2	160	2
BT 50 WE 50 125 AD/6.3G 15000 SL	S10103120164110	50	50	100	M24X2	125	2

Note: • All Dimensions are in mm
 • These Holders are most suitable for Weldon Type End Mill as per standard DIN 1835 - B

**BT (MAS 403) (DIN ISO 7388 - 2) JD
Face Mill Holder (DIN 6357) (FMH) (AD)**

Maximum Run out of the External Dia with respect to the External Taper 0.005 mm

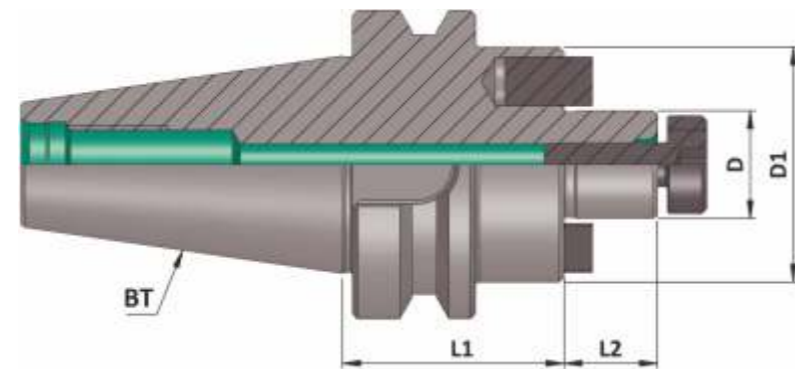

BT (MAS 403) FMH (AD) (JD)

(Balanced to 6.3 G 15000 RPM)

Item Name	Item Code	ISO	D	D1	L1	L2
BT 30 FMH16 035 AD/6.3G 15000 SL S.P.S	S10101126104232	30	16	38	35	17
BT 30 FMH22 040 AD/6.3G 15000 SL S.P.S	S10101127106232	30	22	48	40	19
BT 30 FMH27 040 AD/6.3G 15000 SL S.P.S	S10101128106232	30	27	58	40	21
BT 40 FMH16 045 AD/6.3G 15000 SL S.P.S	S10102126108232	40	16	38	45	17
BT 40 FMH16 100 AD/6.3G 15000 SL S.P.S	S10102126148232	40	16	38	100	17
BT 40 FMH16 160 AD/6.3G 15000 SL S.P.S	S10102126175232	40	16	38	160	17
BT 40 FMH22 045 AD/6.3G 15000 SL S.P.S	S10102127108232	40	22	48	45	19
BT 40 FMH22 100 AD/6.3G 15000 SL S.P.S	S10102127148232	40	22	48	100	19
BT 40 FMH22 160 AD/6.3G 15000 SL S.P.S	S10102127175232	40	22	48	160	19
BT 40 FMH27 045 AD/6.3G 15000 SL S.P.S	S10102128108232	40	27	58	45	21
BT 40 FMH27 100 AD/6.3G 15000 SL S.P.S	S10102128148232	40	27	58	100	21
BT 40 FMH27 160 AD/6.3G 15000 SL S.P.S	S10102128175232	40	27	58	160	21
BT 40 FMH32 050 AD/6.3G 15000 SL S.P.S	S10102129111232	40	32	78	50	24
BT 40 FMH32 100 AD/6.3G 15000 SL S.P.S	S10102129148232	40	32	78	100	24
BT 40 FMH32 160 AD/6.3G 15000 SL S.P.S	S10102129175232	40	32	78	160	24
BT 40 FMH40 055 AD/6.3G 15000 SL S.P.S	S10102130115232	40	40	88	55	27
BT 40 FMH40 100 AD/6.3G 15000 SL S.P.S	S10102130148232	40	40	88	100	27
BT 40 FMH40 160 AD/6.3G 15000 SL S.P.S	S10102130175232	40	40	88	160	27
BT 50 FMH16 060 AD/6.3G 15000 SL S.P.S	S10103126117232	50	16	38	60	17
BT 50 FMH16 100 AD/6.3G 15000 SL S.P.S	S10103126148232	50	16	38	100	17
BT 50 FMH16 160 AD/6.3G 15000 SL S.P.S	S10103126175232	50	16	38	160	17
BT 50 FMH22 060 AD/6.3G 15000 SL S.P.S	S10103127117232	50	22	48	60	19
BT 50 FMH22 100 AD/6.3G 15000 SL S.P.S	S10103127148232	50	22	48	100	19
BT 50 FMH22 160 AD/6.3G 15000 SL S.P.S	S10103127175232	50	22	48	160	19
BT 50 FMH27 060 AD/6.3G 15000 SL S.P.S	S10103128117232	50	27	58	60	21
BT 50 FMH27 100 AD/6.3G 15000 SL S.P.S	S10103128148232	50	27	58	100	21
BT 50 FMH27 160 AD/6.3G 15000 SL S.P.S	S10103128175232	50	27	58	160	21
BT 50 FMH32 060 AD/6.3G 15000 SL S.P.S	S10103129117232	50	32	78	60	24
BT 50 FMH32 100 AD/6.3G 15000 SL S.P.S	S10103129148232	50	32	78	100	24
BT 50 FMH32 160 AD/6.3G 15000 SL S.P.S	S10103129175232	50	32	78	160	24
BT 50 FMH40 060 AD/6.3G 15000 SL S.P.S	S10103130117232	50	40	88	60	27
BT 50 FMH40 100 AD/6.3G 15000 SL S.P.S	S10103130148232	50	40	88	100	27
BT 50 FMH40 160 AD/6.3G 15000 SL S.P.S	S10103130175232	50	40	88	160	27

Note: All Dimensions are in mm

**BT (MAS 403) (DIN ISO 7388 - 2) JD/JF
Face Mill Holder (Through Coolant) (DIN 6357)
(FMH-K) (AD+B)**

Maximum Run out of the External Dia with respect to the External Taper 0.005 mm

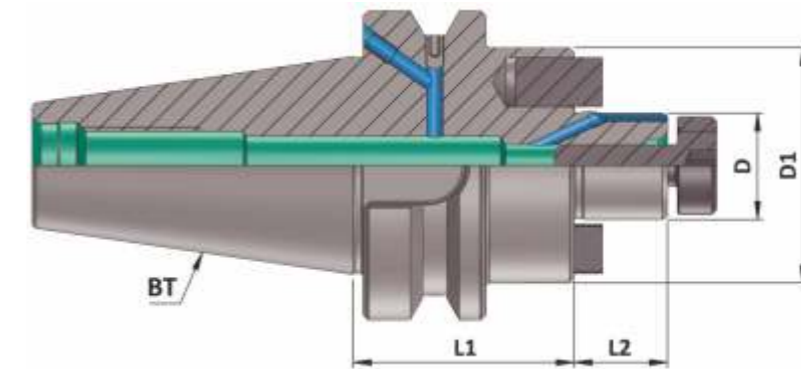

BT (MAS 403) (FMH-K) (AD+ B) (JD/JF)

(Balanced to 6.3 G 15000 RPM)

Item Name	Item Code	ISO	D	D1	L1	L2
BT 40 FMH-K16 045 AD+B/6.3G 15000 SL S.P.S	S10102131108234	40	16	38	45	17
BT 40 FMH-K16 100 AD+B/6.3G 15000 SL S.P.S	S10102131148234	40	16	38	100	17
BT 40 FMH-K16 160 AD+B/6.3G 15000 SL S.P.S	S10102131175234	40	16	38	160	17
BT 40 FMH-K22 045 AD+B/6.3G 15000 SL S.P.S	S10102132108234	40	22	48	45	19
BT 40 FMH-K22 100 AD+B/6.3G 15000 SL S.P.S	S10102132148234	40	22	48	100	19
BT 40 FMH-K22 160 AD+B/6.3G 15000 SL S.P.S	S10102132175234	40	22	48	160	19
BT 40 FMH-K27 045 AD+B/6.3G 15000 SL S.P.S	S10102133108234	40	27	58	45	21
BT 40 FMH-K27 100 AD+B/6.3G 15000 SL S.P.S	S10102133148234	40	27	58	100	21
BT 40 FMH-K27 160 AD+B/6.3G 15000 SL S.P.S	S10102133175234	40	27	58	160	21
BT 40 FMH-K32 050 AD+B/6.3G 15000 SL S.P.S	S10102134111234	40	32	78	50	24
BT 40 FMH-K32 100 AD+B/6.3G 15000 SL S.P.S	S10102134148234	40	32	78	100	24
BT 40 FMH-K32 160 AD+B/6.3G 15000 SL S.P.S	S10102134175234	40	32	78	160	24
BT 40 FMH-K40 055 AD+B/6.3G 15000 SL S.P.S	S10102135115234	40	40	88	55	27
BT 40 FMH-K40 100 AD+B/6.3G 15000 SL S.P.S	S10102135148234	40	40	88	100	27
BT 40 FMH-K40 160 AD+B/6.3G 15000 SL S.P.S	S10102135175234	40	40	88	160	27
BT 50 FMH-K16 060 AD+B/6.3G 15000 SL S.P.S	S10103131117234	50	16	38	60	17
BT 50 FMH-K16 100 AD+B/6.3G 15000 SL S.P.S	S10103131148234	50	16	38	100	17
BT 50 FMH-K16 160 AD+B/6.3G 15000 SL S.P.S	S10103131175234	50	16	38	160	17
BT 50 FMH-K22 060 AD+B/6.3G 15000 SL S.P.S	S10103132117234	50	22	48	60	19
BT 50 FMH-K22 100 AD+B/6.3G 15000 SL S.P.S	S10103132148234	50	22	48	100	19
BT 50 FMH-K22 160 AD+B/6.3G 15000 SL S.P.S	S10103132175234	50	22	48	160	19
BT 50 FMH-K27 060 AD+B/6.3G 15000 SL S.P.S	S10103133117234	50	27	58	60	21
BT 50 FMH-K27 100 AD+B/6.3G 15000 SL S.P.S	S10103133148234	50	27	58	100	21
BT 50 FMH-K27 160 AD+B/6.3G 15000 SL S.P.S	S10103133175234	50	27	58	160	21
BT 50 FMH-K32 060 AD+B/6.3G 15000 SL S.P.S	S10103134117234	50	32	78	60	24
BT 50 FMH-K32 100 AD+B/6.3G 15000 SL S.P.S	S10103134148234	50	32	78	100	24
BT 50 FMH-K32 160 AD+B/6.3G 15000 SL S.P.S	S10103134175234	50	32	78	160	24
BT 50 FMH-K40 060 AD+B/6.3G 15000 SL S.P.S	S10103135117234	50	40	88	60	27
BT 50 FMH-K40 100 AD+B/6.3G 15000 SL S.P.S	S10103135148234	50	40	88	100	27
BT 50 FMH-K40 160 AD+B/6.3G 15000 SL S.P.S	S10103135175234	50	40	88	160	27

Note: All Dimensions are in mm

**BT (MAS 403) (DIN ISO 7388 - 2)
Boring Bar Blank**

**BT (MAS 403)(DIN ISO 7388 - 2)
Master Mandrell**

Maximum Run out of the External Dia with respect to the External Taper 0.003 mm

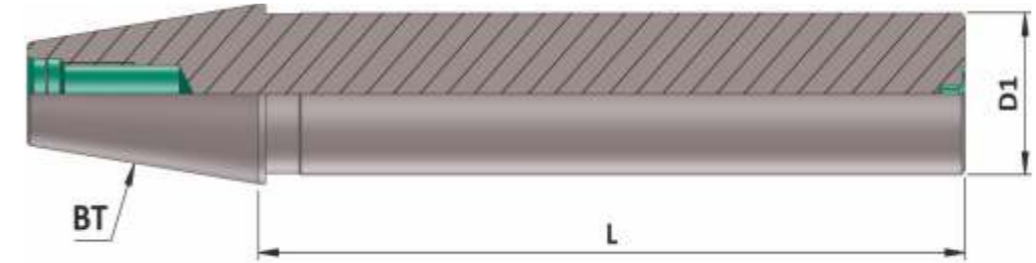
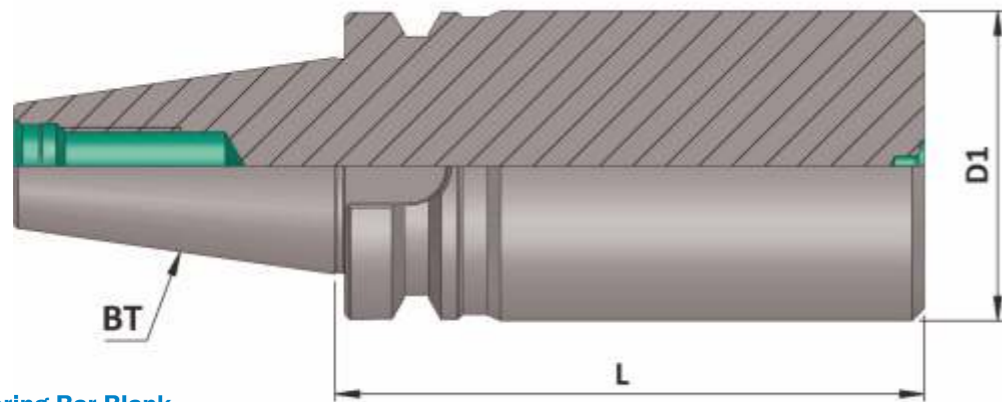

BT (MAS 403) Boring Bar Blank

BT (MAS 403) Master Mandrell

(Sub Zero Treated)

Item Name	Item Code	ISO	D1	L
BT 40 BORING BAR BLANK DIA 63.5 L 120	S10102173498127	40	63.5	120
BT 40 BORING BAR BLANK DIA 63.5 L 160	S10102173330127	40	63.5	160
BT 40 BORING BAR BLANK DIA 63.5 L 250	S10102173256224	40	63.5	250
BT 50 BORING BAR BLANK DIA 80.0 L 160	S10103264330127	50	80	160
BT 50 BORING BAR BLANK DIA 80.0 L 200	S10103264237127	50	80	200
BT 50 BORING BAR BLANK DIA 80.0 L 300	S10103264257127	50	80	300
BT 50 BORING BAR BLANK DIA 97.0 L 315	S10103265329127	50	97	315

Item Name	Item Code	ISO	D1	L
BT 30 MASTER MANDRELL DIA 32 L 250	S10192164256127	30	32	250
BT 40 MASTER MANDRELL DIA 40 L 300	S10102166257127	40	40	300
BT 50 MASTER MANDRELL DIA 50 L 350	S10103166258127	50	50	350

Note: All Dimensions are in mm

Note: All Dimensions are in mm

**BT (MAS 403) (DIN ISO 7388 - 2)
NC Drill Chuck (NCDC)**

Maximum Run out on the Mandrell with respect to the External Taper 0.050 mm

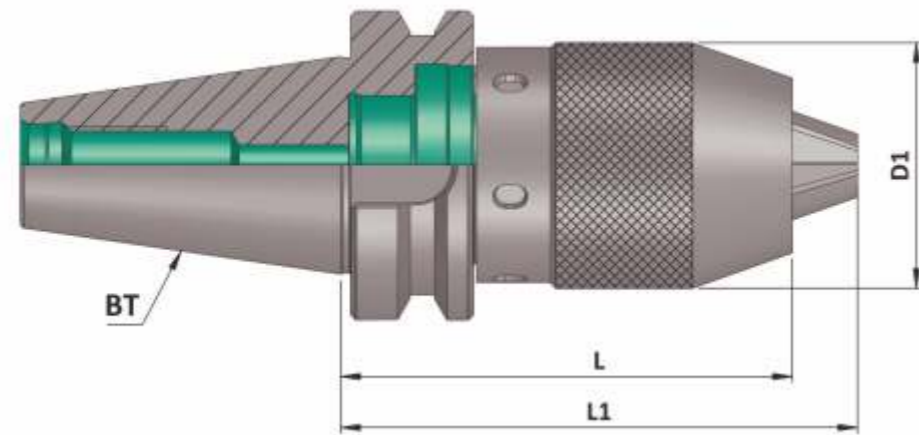

BT (MAS 403)
DIN ISO 7388 - 2 Holders

BT (MAS 403) (NCDC)

Item Name	Item Code	ISO	D1	L	L1
BT 30 NCDC 1-13 112.5	S10101167345122	30	50	112.5	125
BT 40 NCDC 1-13 092.5	S10102167143110	40	50	92.5	105
BT 50 NCDC 1-13 107.5	S10103167151110	50	50	107.5	120

Accessories:

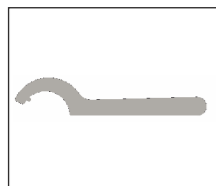

NCDC Spanner
Ref. Page No. 154

Note: All Dimensions are in mm

Die & Mould Chuck (DMC)

◆ **Features :**

- Small outside diameter.
- Best suitable for Die & Mould Industry.
- Most suitable for machining of cavities difficult to reach.
- High precision Runout < 0.005mm (4xd).
- All 'Sigma' Die & Mould Chucks are subjected to Sub-zero treatment (-90° C). This treatment helps to prevent the holders from deformation for many years & hence increases the life.

◆ **Capacity :**

- DMC 06 (3mm to 6mm)
- DMC 08 (3mm to 8 mm)
- DMC 10 (3mm to 10mm)

◆ **Available In Mountings :**

- HSK-A (DIN 69893-1)
- BT (MAS 403) (DIN ISO 7388 - 2)
- BBT (MAS 403)
- SK (DIN 69871) (DIN ISO 7388 - 1)
- Cylindrical Shank

◆ **Balancing :**

- Balanced To 2.5 G 25000 RPM



**BT (MAS 403) (DIN ISO 7388 - 2)
Die & Mould Chuck (DMC)**

Maximum Run out of the Internal Taper with respect to the External Taper < 0.005 mm

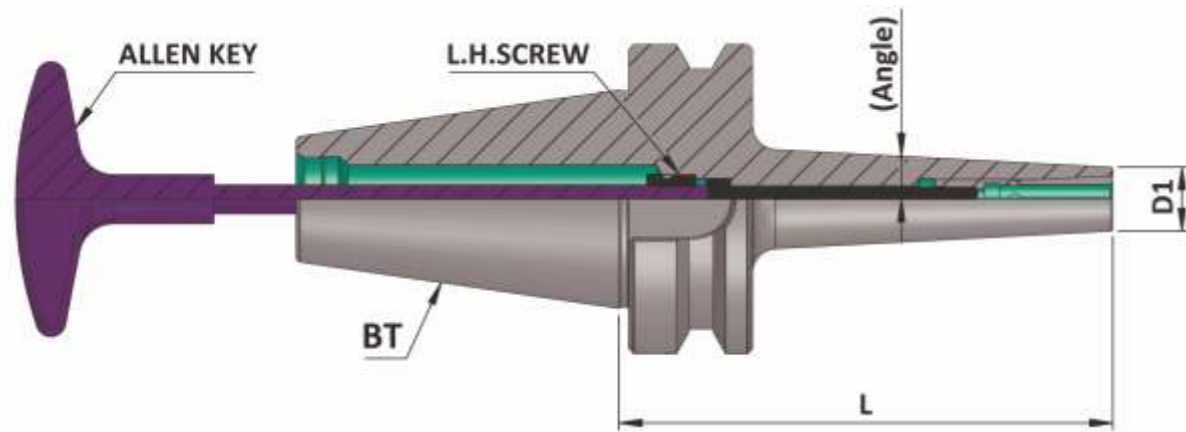

BT (MAS 403)
DIN ISO 7388 - 2 Holders

BT (MAS 403) (DMC)

(Balanced to 2.5 G 25000 RPM)

Item Name	Item Code	ISO	Gripping Range	D1	L	Angle	Suitable Collet	Screw	Allen Key
BT30 DMC 06 090 AD/2.5G 25000 SL	S10101161140114	30	3-6	13	90	3	DMC-6	M5	4X200
BT40 DMC 06 060 AD/2.5G 25000 SL	S10102161117129	40	3-6	13	60	3	DMC-6	M5	4X200
BT40 DMC 06 090 AD/2.5G 25000 SL	S10102161140129	40	3-6	13	90	3	DMC-6	M5	4X200
BT40 DMC 06 120 AD/2.5G 25000 SL	S10102161162129	40	3-6	13	120	3	DMC-6	M5	4X200
BT40 DMC 06 160 AD/2.5G 25000 SL	S10102161175227	40	3-6	13	160	3	DMC-6	M5	4X200
BT40 DMC 08 090 AD/2.5G 25000 SL	S10102162140129	40	3-8	22	90	3	DMC-8	M6	5X200
BT40 DMC 08 120 AD/2.5G 25000 SL	S10102162162129	40	3-8	22	120	3	DMC-8	M6	5X200
BT40 DMC 10 090 AD/2.5G 25000 SL	S10102163140129	40	3-10	28	90	3	DMC-10	M8	6X200
BT40 DMC 10 120 AD/2.5G 25000 SL	S10102163162129	40	3-10	28	120	3	DMC-10	M8	6X200
BT50 DMC 10 150 AD/2.5G 25000 SL	S10103163173129	50	3-10	28	150	3	DMC-10	M8	6X200

Accessories:



DMC Collet
Ref. Page No. 172

Note: All Dimensions are in mm

Power Milling Chuck (PMC)

◆ **Features:**

- 'Sigma' Power Milling Chuck is Very Rigid & Precision.
- It is best for Drilling, Reaming & Milling Operations.
- The tool runs true less than 5 micron on 2D. Hence the tool life increases drastically.
- It's Unibody construction reduces the vibrations, This also helps to increase the tool life.
- All 'Sigma' Power Milling Chucks are subjected to sub-zero treatment (-90° C). This treatment helps to prevent the holders from deformation for many years & hence increases the life.

◆ **Available In Mountings:**

- HSK-A (DIN 69893-1)
- BT (MAS 403) (DIN ISO 7388 - 2)
- BBT (MAS 403)
- SK (DIN 69871) (DIN ISO 7388 - 1)

◆ **Balancing:**

- Balanced To 6.3 G 15000 RPM



**BT (MAS 403) (DIN ISO 7388 - 2)
Power Milling Chuck (PMC)**

Maximum Run out of the Internal Dia with respect to the External Taper 0.005 mm

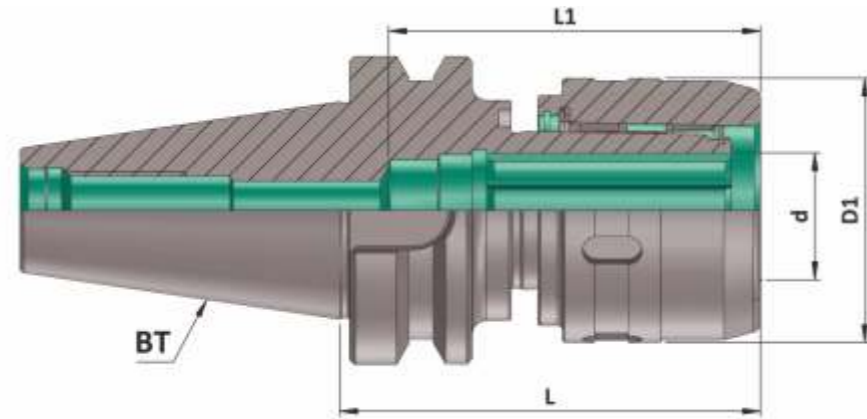

BT (MAS 403) (PMC)

(Balanced to 6.3 G 15000 RPM)

Item Name	Item Code	ISO	d	D1	L	L1
BT 30 C 20075 AD/6.3 G15000 SL	S1010145335212	30	20	54	75	70
BT 40 C 20080 AD/6.3 G15000SL	S10102453353129	40	20	54	80	70
BT 40 C 32090 AD/6.3 G15000SL	S10102453354129	40	32	72	90	100
BT 50 C 20105 AD/6.3 G15000 SL	S10103453355129	50	20	54	105	70
BT 50 C 32105 AD/6.3 G15000 SL	S10103453356129	50	32	72	105	100

Accessories:



Reduction Sleeve (RS)
Ref. Page No. 173

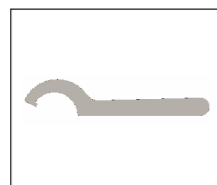

PMC Spanner
Ref. Page No. 174

Note: All Dimensions are in mm

Shrink Fit Holder 4.5 Degree (SFH 4.5°)

◆ **Features :**

- For Mounting Of Carbide Drills, End Mills etc.
- Easy to Reach at Deep Cavities.
- Best T. I. R. & Rigidity during long working life, Result of in house Reasearch & Development & special Heat Treatment.

◆ **Available In Mountings :**

- HSK- A (DIN 69893-1)
- BT (MAS 403) (DIN ISO 7388 - 2)
- BBT (MAS 403)
- SK (DIN 69871) (DIN ISO 7388 - 1)

◆ **Balancing:**

- Balanced To 2.5 G 25000 RPM



**BT (MAS 403) (DIN ISO 7388 - 2) JD
Shrink Fit Holder 4.5 Degree(SFH 4.5°) (AD)**

Maximum Run out of the Internal Dia with respect to the External Taper 0.003 mm

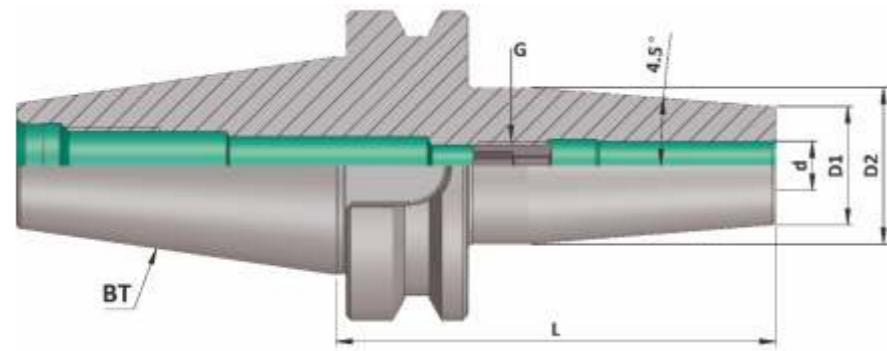

BT (MAS 403) (SFH 4.5°) (AD) JD

(Balanced to 2.5 G 25000 RPM)

Item Name	Item Code	ISO	d	D1	D2	G	L
BT 30 SFH03 080 AD/2.5G 25000 SL	S10101274140129	30	3	10	20	-	80
BT 30 SFH04 080 AD/2.5G 25000 SL	S10101275140129	30	4	15	22	-	80
BT 30 SFH05 080 AD/2.5G 25000 SL	S10101276140129	30	5	15	22	-	80
BT 30 SFH06 080 AD/2.5G 25000 SL	S10101277140129	30	6	21	27	M5	80
BT 30 SFH08 080 AD/2.5G 25000 SL	S10101285140129	30	8	21	27	M6	80
BT 30 SFH10 080 AD/2.5G 25000 SL	S10101279140129	30	10	24	31	M8	80
BT 30 SFH12 080 AD/2.5G 25000 SL	S10101280140129	30	12	24	31	M10	80
BT 30 SFH14 080 AD/2.5G 25000 SL	S10101284140129	30	14	27	34	M10	80
BT 30 SFH16 080 AD/2.5G 25000 SL	S10101281140129	30	16	27	34	M12	80
BT 30 SFH18 080 AD/2.5G 25000 SL	S10101282140129	30	18	33	40	M12	80
BT 30 SFH20 080 AD/2.5G 25000 SL	S10101283140129	30	20	33	40	M16	80

Note: All Dimensions are in mm

**BT (MAS 403) (DIN ISO 7388 - 2) (JD/JF)
Shrink Fit Holder 4.5 Degree (SFH 4.5°) (AD+B)**

Maximum Run out of the Internal Dia with respect to the External Taper 0.003 mm

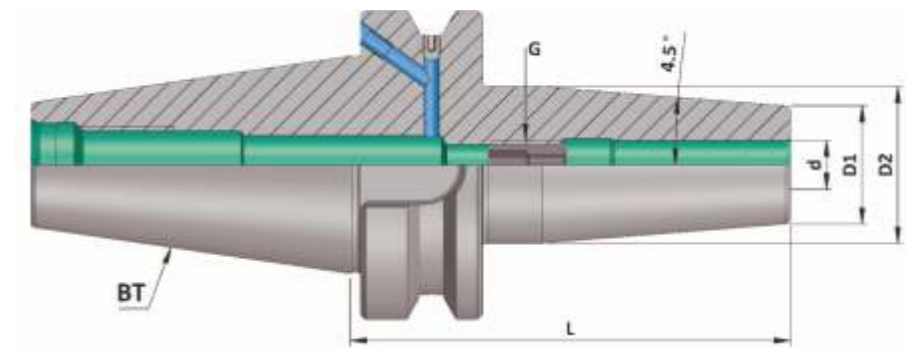

BT (MAS 403) (SFH 4.5°) (AD+B) JD/JF

(Balanced to 2.5 G 25000 RPM)

Item Name	Item Code	ISO	d	D1	D2	G	L
BT 40 SFH03 090 AD+B/2.5G 25000 SL	S10102274140140	40	3	10	20	-	90
BT 40 SFH03 120 AD+B/2.5G 25000 SL	S10102274162140	40	3	10	20	-	120
BT 40 SFH03 160 AD+B/2.5G 25000 SL	S10102274175140	40	3	10	20	-	160
BT 40 SFH04 090 AD+B/2.5G 25000 SL	S10102275140140	40	4	15	22	-	90
BT 40 SFH04 120 AD+B/2.5G 25000 SL	S10102275162140	40	4	15	22	-	120
BT 40 SFH04 160 AD+B/2.5G 25000 SL	S10102275175140	40	4	15	22	-	160
BT 40 SFH05 090 AD+B/2.5G 25000 SL	S10102276140140	40	5	15	22	-	90
BT 40 SFH05 120 AD+B/2.5G 25000 SL	S10102276162140	40	5	15	22	-	120
BT 40 SFH05 160 AD+B/2.5G 25000 SL	S10102276175140	40	5	15	22	-	160
BT 40 SFH06 090 AD+B/2.5G 25000 SL	S10102277140140	40	6	21	27	M5	90
BT 40 SFH06 120 AD+B/2.5G 25000 SL	S10102277162140	40	6	21	27	M5	120
BT 40 SFH06 160 AD+B/2.5G 25000 SL	S10102277175140	40	6	21	27	M5	160
BT 40 SFH08 090 AD+B/2.5G 25000 SL	S10102285140140	40	8	21	27	M6	90
BT 40 SFH08 120 AD+B/2.5G 25000 SL	S10102285162140	40	8	21	27	M6	120
BT 40 SFH08 160 AD+B/2.5G 25000 SL	S10102285175140	40	8	21	27	M6	160
BT 40 SFH10 090 AD+B/2.5G 25000 SL	S10102279140140	40	10	24	31	M8	90
BT 40 SFH10 120 AD+B/2.5G 25000 SL	S10102279162140	40	10	24	31	M8	120
BT 40 SFH10 160 AD+B/2.5G 25000 SL	S10102279175140	40	10	24	31	M8	160
BT 40 SFH12 090 AD+B/2.5G 25000 SL	S10102280140140	40	12	24	31	M10	90
BT 40 SFH12 120 AD+B/2.5G 25000 SL	S10102280162140	40	12	24	31	M10	120
BT 40 SFH12 160 AD+B/2.5G 25000 SL	S10102280175140	40	12	24	31	M10	160

Note: All Dimensions are in mm

**BT (MAS 403) (DIN ISO 7388 - 2) (JD/JF)
Shrink Fit Holder 4.5 Degree (SFH 4.5°) (AD+B)**

Maximum Run out of the Internal Dia with respect to the External Taper 0.003 mm

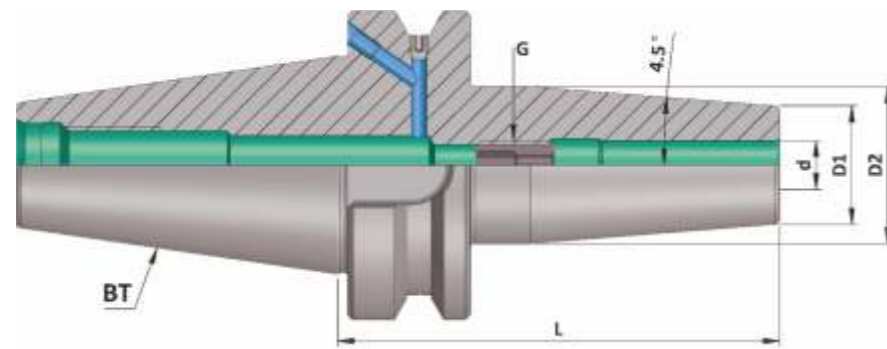

BT (MAS 403) (SFH 4.5°) (AD+B) JD/JF

(Balanced to 2.5 G 25000 RPM)

Item Name	Item Code	ISO	d	D1	D2	G	L
BT 40 SFH14 090 AD+B/2.5G 25000 SL	S10102284140140	40	14	27	34	M10	90
BT 40 SFH14 120 AD+B/2.5G 25000 SL	S10102284162140	40	14	27	34	M10	120
BT 40 SFH14 160 AD+B/2.5G 25000 SL	S10102284175140	40	14	27	34	M10	160
BT 40 SFH16 090 AD+B/2.5G 25000 SL	S10102281140140	40	16	27	34	M12	90
BT 40 SFH16 120 AD+B/2.5G 25000 SL	S10102281162140	40	16	27	34	M12	120
BT 40 SFH16 160 AD+B/2.5G 25000 SL	S10102281175140	40	16	27	34	M12	160
BT 40 SFH18 090 AD+B/2.5G 25000 SL	S10102282140140	40	18	33	40	M12	90
BT 40 SFH18 120 AD+B/2.5G 25000 SL	S10102282162140	40	18	33	40	M12	120
BT 40 SFH18 160 AD+B/2.5G 25000 SL	S10102282175140	40	18	33	40	M12	160
BT 40 SFH20 090 AD+B/2.5G 25000 SL	S10102283140140	40	20	33	40	M16	90
BT 40 SFH20 120 AD+B/2.5G 25000 SL	S10102283162140	40	20	33	40	M16	120
BT 40 SFH20 160 AD+B/2.5G 25000 SL	S10102283175140	40	20	33	40	M16	160
BT 40 SFH25 100 AD+B/2.5G 25000 SL	S10102287148140	40	25	44	53	M16	100
BT 40 SFH25 120 AD+B/2.5G 25000 SL	S10102287162140	40	25	44	53	M16	120
BT 40 SFH25 160 AD+B/2.5G 25000 SL	S10102287175140	40	25	44	53	M16	160
BT 40 SFH32 100 AD+B/2.5G 25000 SL	S10102288148140	40	32	44	53	M16	100
BT 40 SFH32 120 AD+B/2.5G 25000 SL	S10102288162140	40	32	44	53	M16	120
BT 40 SFH32 160 AD+B/2.5G 25000 SL	S10102288175140	40	32	44	53	M16	160

Note: All Dimensions are in mm

**BT (MAS 403) (DIN ISO 7388 - 2) (JD/JF)
Shrink Fit Holder 4.5 Degree (SFH 4.5°) (AD+B)**

Maximum Run out of the Internal Dia with respect to the External Taper 0.003 mm

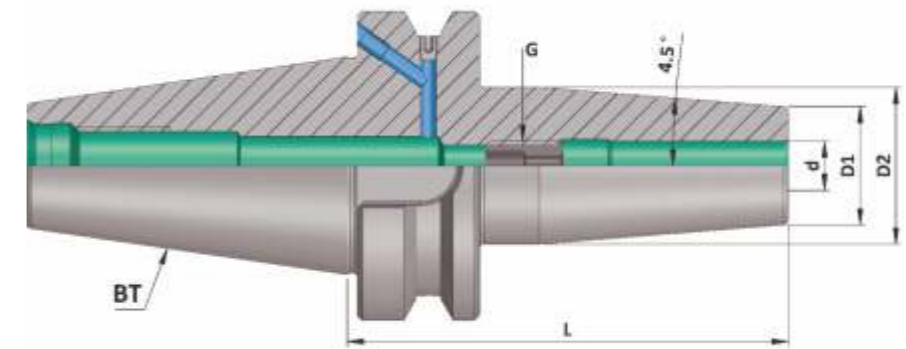

BT (MAS 403) (SFH 4.5°) (AD+B) JD/JF

(Balanced to 2.5 G 25000 RPM)

Item Name	Item Code	ISO	d	D1	D2	G	L
BT 50 SFH03 100 AD+B/2.5G 25000 SL	S10103274148140	50	3	10	20	-	100
BT 50 SFH03 120 AD+B/2.5G 25000 SL	S10103274162140	50	3	10	20	-	120
BT 50 SFH03 160 AD+B/2.5G 25000 SL	S10103274175140	50	3	10	20	-	160
BT 50 SFH04 100 AD+B/2.5G 25000 SL	S10103275148140	50	4	15	22	-	100
BT 50 SFH04 120 AD+B/2.5G 25000 SL	S10103275162140	50	4	15	22	-	120
BT 50 SFH04 160 AD+B/2.5G 25000 SL	S10103275175140	50	4	15	22	-	160
BT 50 SFH05 100 AD+B/2.5G 25000 SL	S10103276148140	50	5	15	22	-	100
BT 50 SFH05 120 AD+B/2.5G 25000 SL	S10103276162140	50	5	15	22	-	120
BT 50 SFH05 160 AD+B/2.5G 25000 SL	S10103276175140	50	5	15	22	-	160
BT 50 SFH06 100 AD+B/2.5G 25000 SL	S10103277148140	50	6	21	27	M5	100
BT 50 SFH06 120 AD+B/2.5G 25000 SL	S10103277162140	50	6	21	27	M5	120
BT 50 SFH06 160 AD+B/2.5G 25000 SL	S10103277175140	50	6	21	27	M5	160
BT 50 SFH08 100 AD+B/2.5G 25000 SL	S10103285148140	50	8	21	27	M6	100
BT 50 SFH08 120 AD+B/2.5G 25000 SL	S10103285162140	50	8	21	27	M6	120
BT 50 SFH08 160 AD+B/2.5G 25000 SL	S10103285175140	50	8	21	27	M6	160
BT 50 SFH10 100 AD+B/2.5G 25000 SL	S10103279148140	50	10	24	31	M8	100
BT 50 SFH10 120 AD+B/2.5G 25000 SL	S10103279162140	50	10	24	31	M8	120
BT 50 SFH10 160 AD+B/2.5G 25000 SL	S10103279175140	50	10	24	31	M8	160
BT 50 SFH12 100 AD+B/2.5G 25000 SL	S10103280148140	50	12	24	31	M10	100
BT 50 SFH12 120 AD+B/2.5G 25000 SL	S10103280162140	50	12	24	31	M10	120
BT 50 SFH12 160 AD+B/2.5G 25000 SL	S10103280175140	50	12	24	31	M10	160

Note: All Dimensions are in mm

**BT (MAS 403) (DIN ISO 7388 - 2) (JD/JF)
Shrink Fit Holder 4.5 Degree (SFH 4.5°) (AD+B)**

Maximum Run out of the Internal Dia with respect to the External Taper 0.003 mm

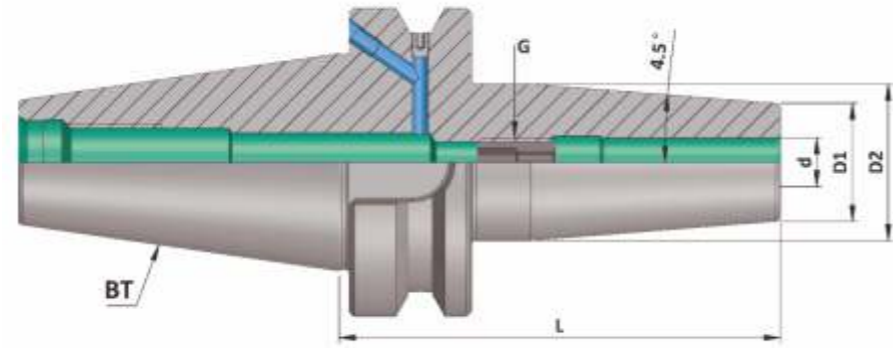

BT (MAS 403) (SFH 4.5°) (AD+B) JD/JF

(Balanced to 2.5 G 25000 RPM)

Item Name	Item Code	ISO	d	D1	D2	G	L
BT 50 SFH14 100 AD+B/2.5G 25000 SL	S10103284148140	50	14	27	34	M10	100
BT 50 SFH14 120 AD+B/2.5G 25000 SL	S10103284162140	50	14	27	34	M10	120
BT 50 SFH14 160 AD+B/2.5G 25000 SL	S10103284175140	50	14	27	34	M10	160
BT 50 SFH16 100 AD+B/2.5G 25000 SL	S10103281148140	50	16	27	34	M12	100
BT 50 SFH16 120 AD+B/2.5G 25000 SL	S10103281162140	50	16	27	34	M12	120
BT 50 SFH16 160 AD+B/2.5G 25000 SL	S10103281175140	50	16	27	34	M12	160
BT 50 SFH18 100 AD+B/2.5G 25000 SL	S10103282148140	50	18	33	40	M12	100
BT 50 SFH18 120 AD+B/2.5G 25000 SL	S10103282162140	50	18	33	40	M12	120
BT 50 SFH18 160 AD+B/2.5G 25000 SL	S10103282175140	50	18	33	40	M12	160
BT 50 SFH20 100 AD+B/2.5G 25000 SL	S10103283148140	50	20	33	40	M16	100
BT 50 SFH20 120 AD+B/2.5G 25000 SL	S10103283162140	50	20	33	40	M16	120
BT 50 SFH20 160 AD+B/2.5G 25000 SL	S10103283175140	50	20	33	40	M16	160
BT 50 SFH25 110 AD+B/2.5G 25000 SL	S10103287156140	50	25	44	53	M16	110
BT 50 SFH25 120 AD+B/2.5G 25000 SL	S10103287162140	50	25	44	53	M16	120
BT 50 SFH25 160 AD+B/2.5G 25000 SL	S10103287175140	50	25	44	53	M16	160
BT 50 SFH32 110 AD+B/2.5G 25000 SL	S10103288156140	50	32	44	53	M16	110
BT 50 SFH32 120 AD+B/2.5G 25000 SL	S10103288162140	50	32	44	53	M16	120
BT 50 SFH32 160 AD+B/2.5G 25000 SL	S10103288175140	50	32	44	53	M16	160

Note: All Dimensions are in mm

**BT (MAS 403) (DIN ISO 7388 - 2) JD
Shrink Fit Holder Slim 3 Degree (SFH Slim 3°) (AD)**

Maximum Run out of the Internal Dia with respect to the External Taper 0.003 mm

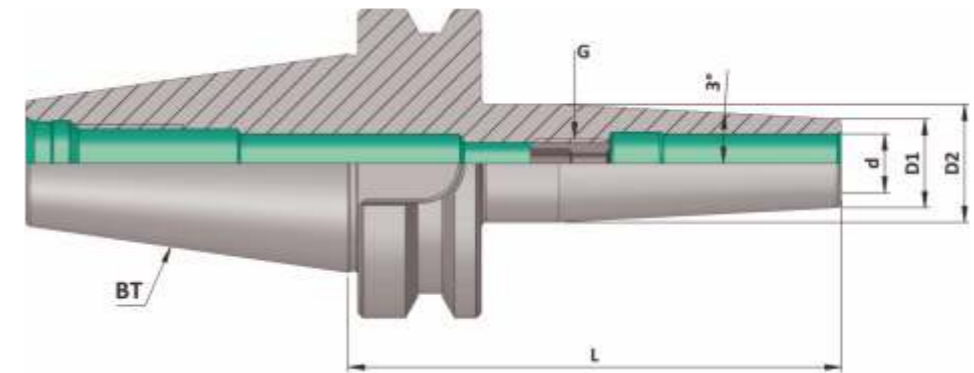

BT (MAS 403) (SFH SLIM 3°) (AD) JD

(Balanced to 2.5 G 25000 RPM)

Item Name	Item Code	ISO	d	D1	D2	G	L
BT30 SFH03 080 SLIM 2.5G 25000 SL	S10101274131258	30	3	9	15	-	80
BT30 SFH03 100 SLIM 2.5G 25000 SL	S10101274148258	30	3	9	18	-	100
BT30 SFH04 080 SLIM 2.5G 25000 SL	S10101275131258	30	4	10	16	-	80
BT30 SFH04 100 SLIM 2.5G 25000 SL	S10101275148258	30	4	10	19	-	100
BT30 SFH05 080 SLIM 2.5G 25000 SL	S10101276131258	30	5	11	17	-	80
BT30 SFH05 100 SLIM 2.5G 25000 SL	S10101276148258	30	5	11	20	-	100
BT30 SFH06 080 SLIM 2.5G 25000 SL	S10101277131258	30	6	12	18	M5	80
BT30 SFH06 100 SLIM 2.5G 25000 SL	S10101277148258	30	6	12	18	M5	100
BT30 SFH08 080 SLIM 2.5G 25000 SL	S10101285131258	30	8	14	20	M6	80
BT30 SFH08 100 SLIM 2.5G 25000 SL	S10101285148258	30	8	14	20	M6	100
BT30 SFH10 080 SLIM 2.5G 25000 SL	S10101279131258	30	10	16	22	M8	80
BT30 SFH10 100 SLIM 2.5G 25000 SL	S10101279148258	30	10	16	22	M8	100
BT30 SFH12 080 SLIM 2.5G 25000 SL	S10101280131258	30	12	18	24	M10	80
BT30 SFH12 100 SLIM 2.5G 25000 SL	S10101280148258	30	12	18	24	M10	100
BT30 SFH14 080 SLIM 2.5G 25000 SL	S10101284131258	30	14	20	26	M10	80
BT30 SFH14 100 SLIM 2.5G 25000 SL	S10101284148258	30	14	20	30	M10	100
BT30 SFH16 080 SLIM 2.5G 25000 SL	S10101281131258	30	16	22	28	M12	80
BT30 SFH16 100 SLIM 2.5G 25000 SL	S10101281148258	30	16	22	32	M12	100
BT30 SFH18 080 SLIM 2.5G 25000 SL	S10101282131258	30	18	24	30	M12	80
BT30 SFH18 100 SLIM 2.5G 25000 SL	S10101282148258	30	18	24	34	M12	100
BT30 SFH20 080 SLIM 2.5G 25000 SL	S10101283131258	30	20	26	32	M16	80
BT30 SFH20 100 SLIM 2.5G 25000 SL	S10101283148258	30	20	26	36	M16	100

Note: All Dimensions are in mm

BT (MAS 403) (DIN ISO 7388 - 2) JD/JF
Shrink Fit Holder Slim 3 Degree (SFH Slim 3°) (AD+B)

Maximum Run out of the Internal Dia with respect to the External Taper 0.003 mm

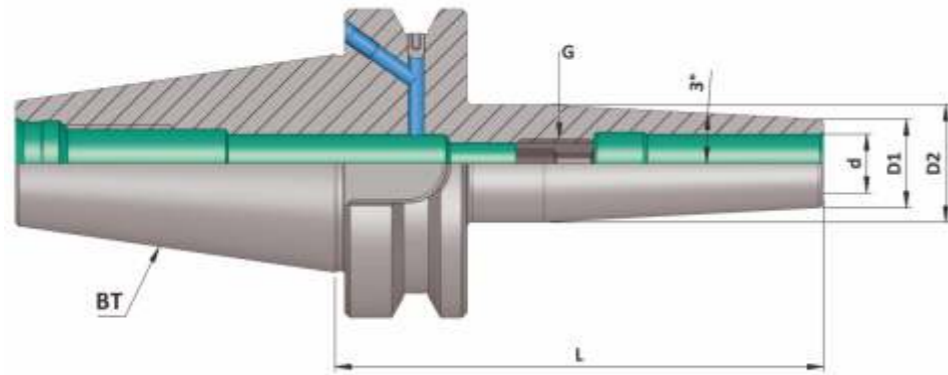

BT (MAS 403) (SFH SLIM 3°) (AD+B) JD/JF

(Balanced to 2.5 G 25000 RPM)

Item Name	Item Code	ISO	d	D1	D2	G	L
BT40 SFH03 090 SLIM AD+B/2.5G 25000 SL	S10102274140259	40	3	9	15	-	90
BT40 SFH03 120 SLIM AD+B/2.5G 25000 SL	S10102274162259	40	3	9	18	-	120
BT40 SFH04 090 SLIM AD+B/2.5G 25000 SL	S10102275140259	40	4	10	16	-	90
BT40 SFH04 120 SLIM AD+B/2.5G 25000 SL	S10102275162259	40	4	10	19	-	120
BT40 SFH05 090 SLIM AD+B/2.5G 25000 SL	S10102276140259	40	5	11	17	-	90
BT40 SFH05 120 SLIM AD+B/2.5G 25000 SL	S10102276162259	40	5	11	20	-	120
BT40 SFH06 090 SLIM AD+B/2.5G 25000 SL	S10102277140259	40	6	12	18	M5	90
BT40 SFH06 120 SLIM AD+B/2.5G 25000 SL	S10102277162259	40	6	12	21	M5	120
BT40 SFH06 160 SLIM AD+B/2.5G 25000 SL	S10102277175259	40	6	12	25	M5	160
BT40 SFH08 090 SLIM AD+B/2.5G 25000 SL	S10102285140259	40	8	14	20	M6	90
BT40 SFH08 120 SLIM AD+B/2.5G 25000 SL	S10102285162259	40	8	14	23	M6	120
BT40 SFH08 160 SLIM AD+B/2.5G 25000 SL	S10102285175259	40	8	14	27	M6	160
BT40 SFH10 090 SLIM AD+B/2.5G 25000 SL	S10102279140259	40	10	16	22	M8	90
BT40 SFH10 120 SLIM AD+B/2.5G 25000 SL	S10102279162259	40	10	16	25	M8	120
BT40 SFH10 160 SLIM AD+B/2.5G 25000 SL	S10102279175259	40	10	16	29	M8	160
BT40 SFH12 090 SLIM AD+B/2.5G 25000 SL	S10102280140259	40	12	18	24	M10	90
BT40 SFH12 120 SLIM AD+B/2.5G 25000 SL	S10102280162259	40	12	18	27	M10	120
BT40 SFH12 160 SLIM AD+B/2.5G 25000 SL	S10102280175259	40	12	18	31	M10	160
BT40 SFH14 090 SLIM AD+B/2.5G25000 SL	S10102284140258	40	14	20	26	M10	90
BT40 SFH14 120 SLIM AD+B/2.5G25000 SL	S10102284162258	40	14	20	29	M10	120
BT40 SFH14 160 SLIM AD+B/2.5G25000 SL	S10102284175258	40	14	20	32	M10	160
BT40 SFH16 090 SLIM AD+B/2.5G25000 SL	S10102281140258	40	16	22	28	M12	90
BT40 SFH16 120 SLIM AD+B/2.5G25000 SL	S10102281162258	40	16	22	31	M12	120
BT40 SFH16 160 SLIM AD+B/2.5G25000 SL	S10102281175258	40	16	22	34	M12	160
BT40 SFH18 090 SLIM AD+B/2.5G25000 SL	S10102282140258	40	18	24	30	M12	90
BT40 SFH18 120 SLIM AD+B/2.5G25000 SL	S10102282162258	40	18	24	33	M12	120
BT40 SFH18 160 SLIM AD+B/2.5G25000 SL	S10102282175258	40	18	24	36	M12	160
BT40 SFH20 090 SLIM AD+B/2.5G25000 SL	S10102283140258	40	20	26	32	M16	90
BT40 SFH20 120 SLIM AD+B/2.5G25000 SL	S10102283162258	40	20	26	35	M16	120
BT40 SFH20 160 SLIM AD+B/2.5G25000 SL	S10102283175258	40	20	26	38	M16	160

Note: All Dimensions are in mm

BT (MAS 403) (DIN ISO 7388 - 2) JD/JF
Shrink Fit Holder Slim 3 Degree (SFH Slim 3°) (AD+B)

Maximum Run out of the Internal Dia with respect to the External Taper 0.003 mm

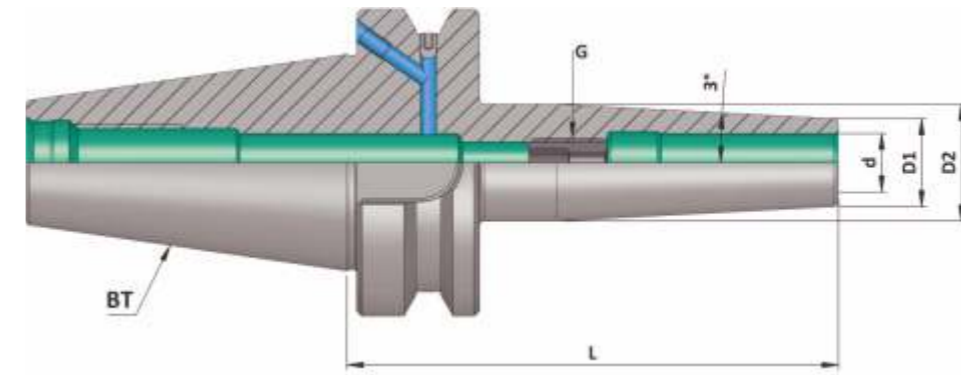

BT (MAS 403) (SFH SLIM 3°) (AD+B) JD/JF

(Balanced to 2.5 G 25000 RPM)

Item Name	Item Code	ISO	d	D1	D2	G	L
BT50 SFH03 100 SLIM AD+B/2.5G 25000 SL	S10103274148259	50	3	9	15.5	-	100
BT50 SFH03 120 SLIM AD+B/2.5G 25000 SL	S10103274162259	50	3	9	17.5	-	120
BT50 SFH04 100 SLIM AD+B/2.5G 25000 SL	S10103275148259	50	4	10	16.5	-	100
BT50 SFH04 120 SLIM AD+B/2.5G 25000 SL	S10103275162259	50	4	10	18.5	-	120
BT50 SFH05 100 SLIM AD+B/2.5G 25000 SL	S10103276148259	50	5	11	17.5	-	100
BT50 SFH05 120 SLIM AD+B/2.5G 25000 SL	S10103276162259	50	5	11	19.5	-	120
BT50 SFH06 100 SLIM AD+B/2.5G 25000 SL	S10103277148259	50	6	12	18.5	M5	100
BT50 SFH06 120 SLIM AD+B/2.5G 25000 SL	S10103277162259	50	6	12	20.5	M5	120
BT50 SFH06 160 SLIM AD+B/2.5G 25000 SL	S10103277175259	50	6	12	25	M5	160
BT50 SFH08 100 SLIM AD+B/2.5G 25000 SL	S10103285148259	50	8	14	20.5	M6	100
BT50 SFH08 120 SLIM AD+B/2.5G 25000 SL	S10103285162259	50	8	14	22.5	M6	120
BT50 SFH08 160 SLIM AD+B/2.5G 25000 SL	S10103285175259	50	8	14	27	M6	160
BT50 SFH10 100 SLIM AD+B/2.5G 25000 SL	S10103279148259	50	10	16	22.5	M8	100
BT50 SFH10 120 SLIM AD+B/2.5G 25000 SL	S10103279162259	50	10	16	24.5	M8	120
BT50 SFH10 160 SLIM AD+B/2.5G 25000 SL	S10103279175259	50	10	16	29	M8	160
BT50 SFH12 100 SLIM AD+B/2.5G 25000 SL	S10103280148259	50	12	18	24.5	M10	100
BT50 SFH12 120 SLIM AD+B/2.5G 25000 SL	S10103280162259	50	12	18	26.5	M10	120
BT50 SFH12 160 SLIM AD+B/2.5G 25000 SL	S10103280175259	50	12	18	31	M10	160
BT50 SFH14 100 SLIM AD+B/2.5G 25000 SL	S10103284148259	50	14	20	26	M10	100
BT50 SFH14 120 SLIM AD+B/2.5G 25000 SL	S10103284162259	50	14	20	29	M10	120
BT50 SFH14 160 SLIM AD+B/2.5G 25000 SL	S10103284175259	50	14	20	32	M10	160
BT50 SFH16 100 SLIM AD+B/2.5G 25000 SL	S10103281148259	50	16	22	28	M12	100
BT50 SFH16 120 SLIM AD+B/2.5G 25000 SL	S10103281162259	50	16	22	31	M12	120
BT50 SFH16 160 SLIM AD+B/2.5G 25000 SL	S10103281175259	50	16	22	34	M12	160
BT50 SFH18 100 SLIM AD+B/2.5G 25000 SL	S10103282148259	50	18	24	30	M12	100
BT50 SFH18 120 SLIM AD+B/2.5G 25000 SL	S10103282162259	50	18	24	33	M12	120
BT50 SFH18 160 SLIM AD+B/2.5G 25000 SL	S10103282175259	50	18	24	36	M12	160
BT50 SFH20 100 SLIM AD+B/2.5G 25000 SL	S10103283148259	50	20	26	32	M16	100
BT50 SFH20 120 SLIM AD+B/2.5G 25000 SL	S10103283162259	50	20	26	35	M16	120
BT50 SFH20 160 SLIM AD+B/2.5G 25000 SL	S10103283175259	50	20	26	38	M16	160

Note: All Dimensions are in mm

Minimum Length Compensation Tapping Chuck (MLC)

◆ Features :

- Sigma "Minimum Length Compensation Tapping Chuck (MLC)" For Synchronised (Rigid) Tapping Cycle.
- Best suitable for Die & Mould Industry.
- Compression & Expansion +/- 0.5mm
- High Concentricity Enables High Speed Tapping.
- Positive Clamping Through ER Tap Collet.

◆ Technical Details :

- "MLC" Tapping Chucks to be used with CNC Machines, having Synchronised Tapping cycle.
- In this case, Rigid Tapping cycle takes care of tap pitch controlling the feed, spindle speed and feed. So, theoretically, ordinary holder without any compensation also should be suitable for performing the process.
- ◆ But by law of theory, following factors they do affect tapping quality, tap life etc.
 1. Dynamics of machine
 2. Synchronisation of spindle speed & feed.
 3. During Change of Spindle, Rotational direction and feed direction.
 4. Pitch error on Tap / Tolerance on Pitch

◆ This will lead to :

1. Less Tap life because of Flank wear (one side)
2. Damaged Flanks on threads on the work piece
3. Threads not answering to Gauge.

◆ All above errors can be taken care by using ' MLC '

◆ Sigma 'MLC' Tapping Chucks with +/- 0.5 mm compensation.

◆ Available In Following Range :

- ER 16 : M3 to M12
- ER 20 : M3 to M16
- ER 25 : M3 to M20
- ER 32 : M4 to M27
- ER 40 : M6 to M33

◆ Available In Mountings :

- HSK- A (DIN 69893-1)
- BT (MAS 403) (DIN ISO 7388 - 2)
- BBT (MAS 403)
- SK (DIN 69871) (DIN ISO 7388 - 1)
- Cylindrical Shank

◆ Balancing :

- Main Body Balanced to 2.5G 25000 RPM



SK (DIN 69871) (DIN ISO 7388- 1) Minimum Length Compensation Tapping Chuck (MLC)

SIGMA
TOOLINGS

Maximum Run out of the Internal Taper with respect to the External Taper 0.020 mm

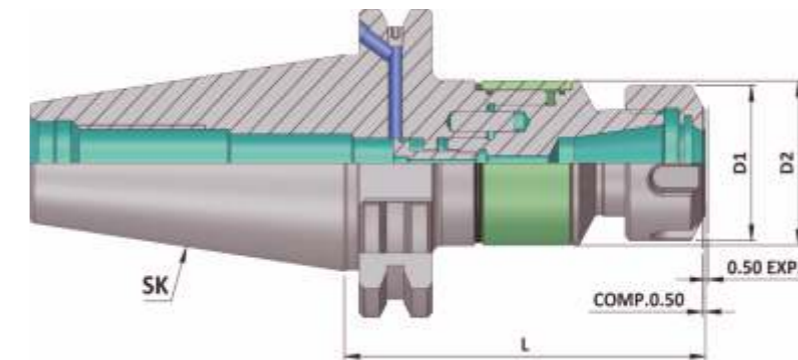

SK (DIN 69871) (MLC)

Item Name	Item Code	SK	Capacity	Clamping Range	Nut Size	D1	D2	L	Comp.	Exp.
SK 40 ER 16M 079 AD+B MLC	S10104157551245	40	M3-M12	1-10	ER 16M	22	34	79		0.5
SK 40 ER 16 079 AD+B MLC	S10104149551245	40	M3-M12	1-10	ER 16	32	34	79		0.5
SK 40 ER 20 080 AD+B MLC	S10104150131250	40	M3-M16	3.5-10	ER 20	35	34	80		0.5
SK 40 ER 25 084 AD+B MLC	S10104151134245	40	M3-M20	3.5-16	ER 25	42	34	84		0.5
SK 40 ER 32 095 AD+B MLC	S10104152145245	40	M4-M27	3.5-20	ER 32	50	45	95		0.5
SK 40 ER 40 120 AD+B MLC	S10104153162245	40	M6-M33	6-26	ER 40	63	62	120		0.5

SK 50 ER 16M 079 AD+B MLC	S10105157551250	50	M3-M12	1-10	ER 16M	22	34	79		0.5
SK 50 ER 16 079 AD+B MLC	S10105149551245	50	M3-M12	1-10	ER 16	32	34	79		0.5
SK 50 ER 20 080 AD+B MLC	S10105150131250	50	M3-M16	3.5-10	ER 20	35	34	80		0.5
SK 50 ER 25 084 AD+B MLC	S10105151134245	50	M3-M20	3.5-16	ER 25	42	34	84		0.5
SK 50 ER 32 095 AD+B MLC	S10105152145245	50	M4-M27	3.5-20	ER 32	50	45	95		0.5
SK 50 ER 40 105 AD+B MLC	S10105153152245	50	M6-M33	6-26	ER 40	63	62	105		0.5

Accessories:



Tap Collet ER G
Ref. Page No. 169-171



Q.C. Tap Collet QCTC
Ref. Page No. 174-182



ER Nut
Ref. Page No. 151-152







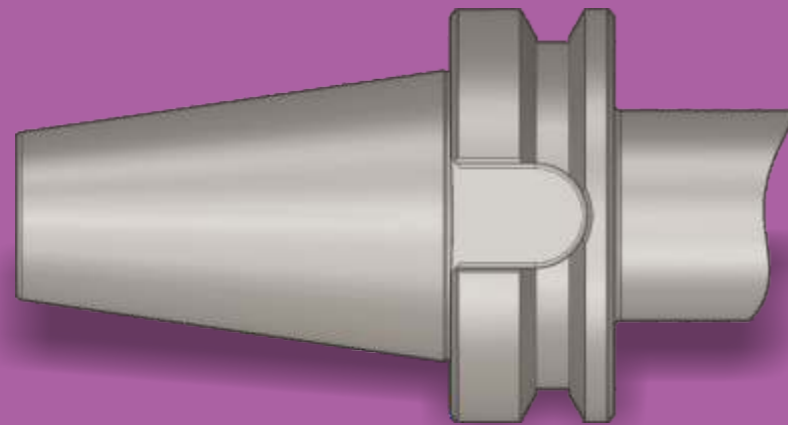

ER Spanner
Ref. Page No. 153

Note: All Dimensions are in mm



**Taper & Both Face
Contact Holder
BBT (BT MAS 403)**



INDEX

Sr. No.	Contents		Page No.
1	Technical Information : BBT (BT MAS 403) (Taper & Both Face Contact Holder)		65 - 66
2	BBT Collet Chuck ER (DIN 6499) <ul style="list-style-type: none"> • Collet Chuck ER (AD) • Collet Chuck ER M Type (AD) • Collet Chuck ER A Type (Short GP) 		67 - 70
3	BBT Weldon Type End Mill Holders (DIN 6359) <ul style="list-style-type: none"> • Weldon (WE) (AD) 		71 - 73
4	BBT Face Mill Holders (DIN 6357) <ul style="list-style-type: none"> • FMH (AD) • FMH-K (Through Coolant) (AD) 		74 - 75
5	BBT Boring Bar Blank		76
6	BBT NC Drill Chuck (NCDC)		77
7	BBT Die & Mould Chuck (DMC)		78 - 79
8	BBT Power Milling Chuck (PMC)		80 - 81

INDEX

Sr. No.	Contents		Page No.
9	BBT Shrink Fit Holders 4.5 Degree (SFH 4.5°) <ul style="list-style-type: none"> • Shrink Fit Holder (SFH 4.5°) (AD) • Shrink Fit Holder (SFH FCC 4.5°) (AD) (Face Coolant Channel) 		82 - 92
10	BBT Shrink Fit Holders Slim 3 Degree (SFH Slim 3°)		93 - 95
11	BBT Minimum Length Compensation Tapping Chuck (MLC)		96 - 97

BBT (BT MAS 403)

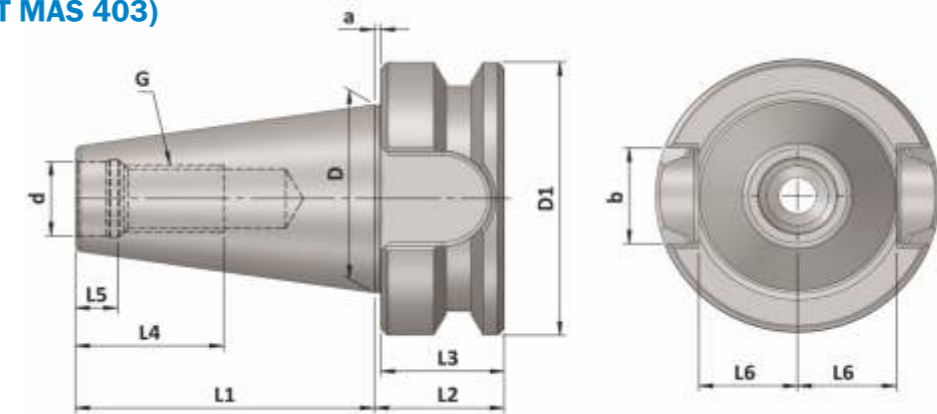

ISO	d	D	D1	a	b	G	L1	L2	L3	L4	L5	L6
30	12.5	31.75	46	1	16.1	M12	48.4	21	20	24	7.0	16.3
40	17	44.45	63	1	16.1	M16	65.4	27	26	32	9.0	22.6
50	25	69.85	100	1.5	25.7	M24	101.8	38	36.5	47	13.0	35.4

◆ Features:

- BBT Tool Holder Provides More “Rigid” Clamping than the Standard “BT” Tool Holders.
- Achieves Higher “Radial Rigidity”
- Improves Tool life.
- Balanced to 2.5 G, 25000 RPM.

● **Material** :- Case hardened steel, tensile strength in the core min. 950 N/mm²

● **Execution** :- Case hardened to HRC 58 ± 2, Case Depth 0.8 mm., Silver finish.

● **Accuracy** :- 7:24 Taper Angle Class AT 3 As per DIN 2080

Note: All Dimensions are in mm

BBT (BT MAS 403) : Technical Information

**BBT (BT MAS 403)
TAPER AND BOTH FACE CONTACT HOLDER
(After Clamping)**

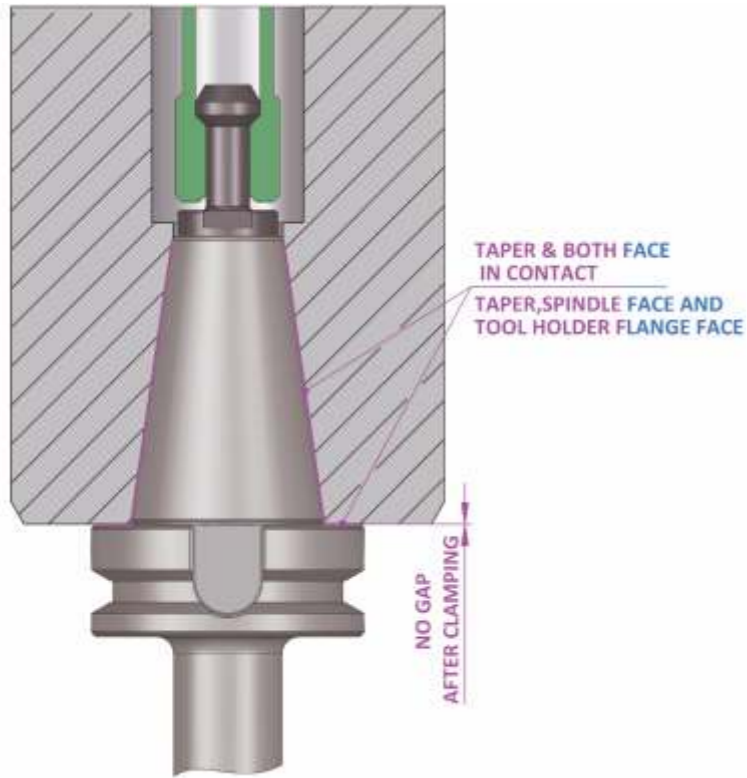

**BT (MAS 403) STANDARD HOLDER
(ONLY TAPER CONTACT)
(After Clamping)**

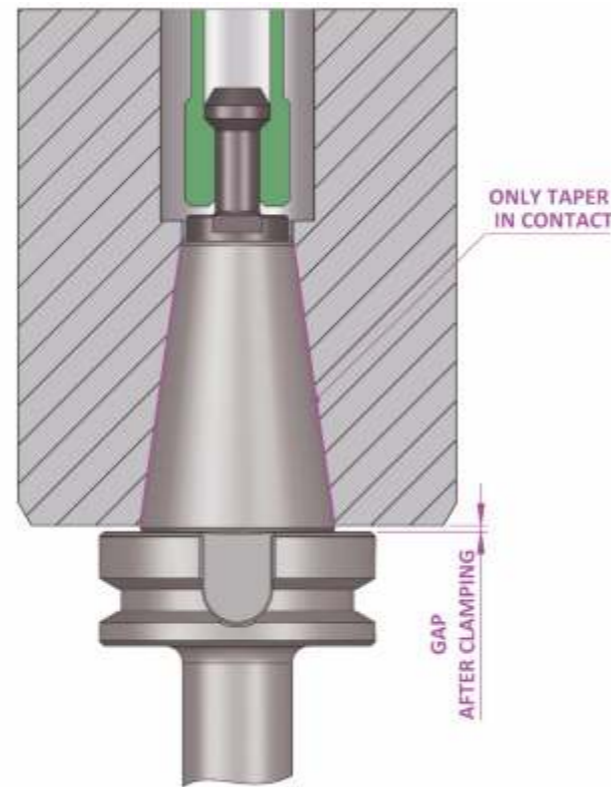

In BBT Tool Holder as mentioned Taper and both faces are in contact, due to which spindle and holder acts as one single unit, this allows a Higher “Radial Rigidity” hence we get good surface finish and dimensional accuracy while machining, also low vibration at higher speeds which increases Tool Life. Hence BBT Tool Holder has a remarkable significant as compared to Standard Tool Holders.

Note :
BBT Tool Holders are only recommended to use in Calibrated BBT Spindle Machines.

BBT (BT MAS 403) Collet Chuck ER (AD) (DIN 6499)



Maximum Run out of the Internal Taper with respect to the External Taper 0.005 mm

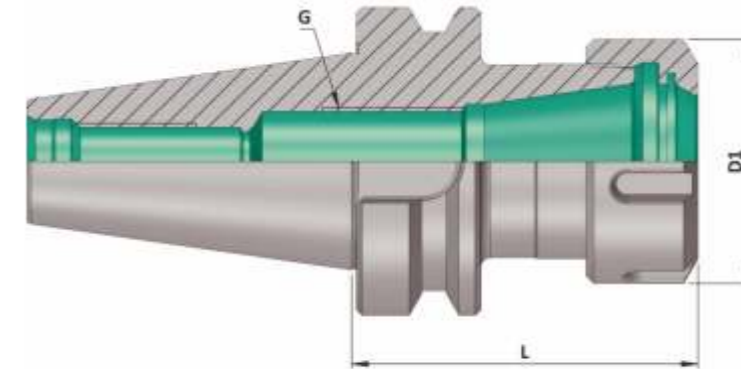

BBT (Collet Chuck ER) (AD)

(Balanced to 2.5 G 25000 RPM)

Item Name	Item Code	ISO	Suitable Collet	Collet Capacity	D1	G	L	Nut	Spanner
BBT30 ER 16 060 AD/2.5G 25000 SL	S10307149117110	30	ER 16	0.5-10	32	M10X1	60	UM/ER16	E16
BBT30 ER 16 100 AD/2.5G 25000 SL	S10307149148110	30	ER 16	0.5-10	32	M10X1	100	UM/ER16	E16
BBT30 ER 20 060 AD/2.5G 25000 SL	S10307150117110	30	ER 20	1.0-13	35	M10X1	60	UM/ER20	E20
BBT30 ER 20 100 AD/2.5G 25000 SL	S10307150148110	30	ER 20	1.0-13	35	M10X1	100	UM/ER20	E20
BBT30 ER 25 060 AD/2.5G 25000 SL	S10307151117110	30	ER 25	1.0-16	42	M18X1	60	UM/ER25	E25
BBT30 ER 25 100 AD/2.5G 25000 SL	S10307151148110	30	ER 25	1.0-16	42	M18X1	100	UM/ER25	E25
BBT30 ER 32 050 AD/2.5G 25000 SL	S10307152111228	30	ER32	2.0-20	50	M22X1.5	50	UM/ER32	E32
BBT30 ER 32 060 AD/2.5G 25000 SL	S10307152117110	30	ER 32	2.0-20	50	M22X1.5	60	UM/ER32	E32
BBT30 ER 32 100 AD/2.5G 25000 SL	S10307152148110	30	ER 32	2.0-20	50	M22X1.5	100	UM/ER32	E32
BBT30 ER 40 080 AD/2.5G 25000 SL	S10307153131110	30	ER 40	3.0-26	63	M30X1.5	80	UM/ER40	E40

BBT40 ER 16 070 AD/2.5G 25000 SL	S10291149125110	40	ER16	0.5-10	32	M10x1	70	UM/ER16	E16
BBT40 ER 16 100 AD/2.5G 25000 SL	S10291149148110	40	ER16	0.5-10	32	M10x1	100	UM/ER16	E16
BBT40 ER 16 160 AD/2.5G 25000 SL	S10291149175110	40	ER16	0.5-10	32	M10x1	160	UM/ER16	E16
BBT40 ER 20 070 AD/2.5G 25000 SL	S10291150125110	40	ER20	1.0-13	35	M10x1	70	UM/ER20	E20
BBT40 ER 20 100 AD/2.5G 25000 SL	S10291150148110	40	ER20	1.0-13	35	M10x1	100	UM/ER20	E20
BBT40 ER 20 160 AD/2.5G 25000 SL	S10291150175110	40	ER20	1.0-13	35	M10x1	160	UM/ER20	E20
BBT40 ER 25 070 AD/2.5G 25000 SL	S10291151125110	40	ER25	1.0-16	42	M18x1	70	UM/ER25	E25
BBT40 ER 25 100 AD/2.5G 25000 SL	S10291151148110	40	ER25	1.0-16	42	M18x1	100	UM/ER25	E25
BBT40 ER 25 160 AD/2.5G 25000 SL	S10291151175110	40	ER25	1.0-16	42	M18x1	160	UM/ER25	E25
BBT40 ER 32 070 AD/2.5G 25000 SL	S10291152125110	40	ER32	2.0-20	50	M22x1.5	70	UM/ER32	E32
BBT40 ER 32 100 AD/2.5G 25000 SL	S10291152148110	40	ER32	2.0-20	50	M22x1.5	100	UM/ER32	E32
BBT40 ER 32 160 AD/2.5G 25000 SL	S10291152175110	40	ER32	2.0-20	50	M22x1.5	160	UM/ER32	E32
BBT40 ER 40 070 AD/2.5G 25000 SL	S10291153125110	40	ER40	3.0-26	63	M30x1.5	70	UM/ER40	E40
BBT40 ER 40 100 AD/2.5G 25000 SL	S10291153148110	40	ER40	3.0-26	63	M30x1.5	100	UM/ER40	E40
BBT40 ER 40 160 AD/2.5G 25000 SL	S10291153175110	40	ER40	3.0-26	63	M30x1.5	160	UM/ER40	E40
BBT40 ER 50 100 AD/2.5G 25000 SL	S10291154148110	40	ER50	10.0-34	78	M16x2	100	UM/ER50	E50

Note: All Dimensions are in mm

BBT (MAS 403)
Holders

**BBT (BT MAS 403)
Collet Chuck ER (AD) (DIN 6499)**

Maximum Run out of the Internal Taper with respect to the External Taper 0.005 mm

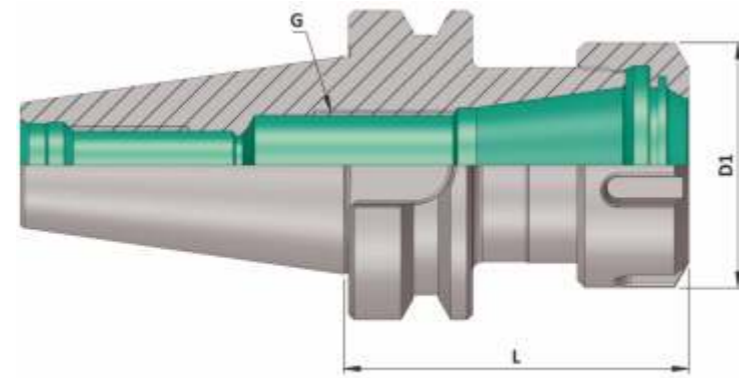

BBT (MAS 403)
Holders

BBT (Collet Chuck ER) (AD)

(Balanced to 2.5 G 25000 RPM)

Item Name	Item Code	ISO	Suitable Collet	Collet Capacity	D1	G	L	Nut	Spanner
BBT50 ER 16 080 AD/2.5G 25000 SL	S10308149131110	50	ER16	0.5-10	32	M10X1	80	UM/ER16	E16
BBT50 ER 16 100 AD/2.5G 25000 SL	S10308149148110	50	ER16	0.5-10	32	M10X1	100	UM/ER16	E16
BBT50 ER 16 160 AD/2.5G 25000 SL	S10308149175110	50	ER16	0.5-10	32	M10X1	160	UM/ER16	E16
BBT50 ER 20 100 AD/2.5G 25000 SL	S10308150148110	50	ER20	1.0-13	35	M10X1	100	UM/ER20	E20
BBT50 ER 20 160 AD/2.5G 25000 SL	S10308150175110	50	ER20	1.0-13	35	M10X1	160	UM/ER20	E20
BBT50 ER 25 080 AD/2.5G 25000 SL	S10308151131110	50	ER25	1.0-16	42	M18X1	80	UM/ER25	E25
BBT50 ER 25 100 AD/2.5G 25000 SL	S10308151148110	50	ER25	1.0-16	42	M18X1	100	UM/ER25	E25
BBT50 ER 25 160 AD/2.5G 25000 SL	S10308151175110	50	ER25	1.0-16	42	M18X1	160	UM/ER25	E25
BBT50 ER 32 080 AD/2.5G 25000 SL	S10308152131110	50	ER32	2.0-20	50	M22X1.5	80	UM/ER32	E32
BBT50 ER 32 100 AD/2.5G 25000 SL	S10308152148110	50	ER32	2.0-20	50	M22X1.5	100	UM/ER32	E32
BBT50 ER 32 160 AD/2.5G 25000 SL	S10308152175110	50	ER32	2.0-20	50	M22X1.5	160	UM/ER32	E32
BBT50 ER 40 080 AD/2.5G 25000 SL	S10308153131110	50	ER40	3.0-26	63	M30X1.5	80	UM/ER40	E40
BBT50 ER 40 100 AD/2.5G 25000 SL	S10308153148110	50	ER40	3.0-26	63	M30X1.5	100	UM/ER40	E40
BBT50 ER 40 160 AD/2.5G 25000 SL	S10308153175110	50	ER40	3.0-26	63	M30X1.5	160	UM/ER40	E40
BBT50 ER 50 100 AD/2.5G 25000 SL	S10308154148110	50	ER50	10.0-34	78	M16X2	100	UM/ER50	E50
BBT50 ER 50 160 AD/2.5G 25000 SL	S10308154175110	50	ER50	10.0-34	78	M16X2	160	UM/ER50	E50

Accessories:



Collet ER (DIN 6499)
Ref. Page No. 164-168



Tap Collet ER-G
Ref. Page No. 169-171



Q.C.Tap Collet (QCTC)
Ref. Page No. 174-182



ER Nut
Ref. Page No. 151-152

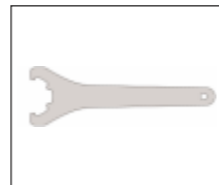

ER Spanner
Ref. Page No. 153

Note: All Dimensions are in mm

**BBT (BT MAS 403)
Collet Chuck ER - M (AD) (DIN 6499)**

Maximum Run out of the Internal Taper with respect to the External Taper 0.005 mm

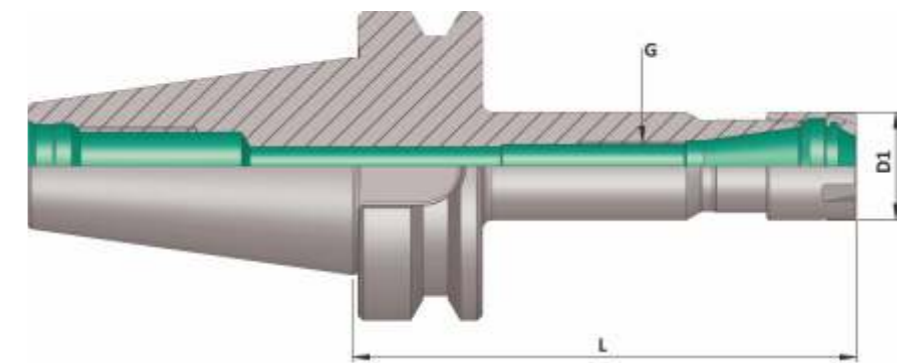

BBT (MAS 403)
Holders

BBT (Collet Chuck ER - M Type) (AD)

(Balanced to 2.5 G 25000 RPM)

Item Name	Item Code	ISO	Suitable Collet	Collet Capacity	D1	G	L	Nut	Spanner
BBT40 ER11M 070 AD/2.5G 25000 SL	S10291156125228	40	ER11	0.5-7	16	M6X1	70	ER11M	E11M
BBT40 ER11M 100 AD/2.5G 25000 SL	S10291156148228	40	ER11	0.5-7	16	M6X1	100	ER11M	E11M
BBT40 ER11M 160 AD/2.5G 25000 SL	S10291156175228	40	ER11	0.5-7	16	M6X1	160	ER11M	E11M
BBT40 ER16M 070 AD/2.5G 25000 SL	S10291157125228	40	ER16	0.5-10	22	M10X1	70	ER16M	E16M
BBT40 ER16M 100 AD/2.5G 25000 SL	S10291157148228	40	ER16	0.5-10	22	M10X1	100	ER16M	E16M
BBT40 ER16M 120 AD/2.5G 25000 SL	S10291157162228	40	ER16	0.5-10	22	M10X1	120	ER16M	E16M
BBT40 ER16M 160 AD/2.5G 25000 SL	S10291157175228	40	ER16	0.5-10	22	M10X1	160	ER16M	E16M
BBT40 ER20M 120 AD/2.5G 25000 SL	S10291158162228	40	ER20	1.0-13	28	M10X1	120	ER20M	E20M
BBT40 ER20M 160 AD/2.5G 25000 SL	S10291158175228	40	ER20	1.0-13	28	M10X1	160	ER20M	E20M
BBT40 ER25M 070 AD/2.5G 25000 SL	S10291159125228	40	ER25	1.0-16	35	M18X1	70	ER25M	E25M
BBT40 ER25M 100 AD/2.5G 25000 SL	S10291159148228	40	ER25	1.0-16	35	M18X1	100	ER25M	E25M
BBT40 ER25M 120 AD/2.5G 25000 SL	S10291159162228	40	ER25	1.0-16	35	M18X1	120	ER25M	E25M
BBT40 ER25M 160 AD/2.5G 25000 SL	S10291159175228	40	ER25	1.0-16	35	M18X1	160	ER25M	E25M

Accessories:



Collet ER (DIN 6499)
Ref. Page No. 164-168



Tap Collet ER-G
Ref. Page No. 169-171



Q.C.Tap Collet (QCTC)
Ref. Page No. 174-182



ER - M Nut
Ref. Page No. 151-152



ER M Type Spanner
Ref. Page No. 153

Note: All Dimensions are in mm

**BBT (BT MAS 403)
Short GP Collet Chuck ER-A**

Maximum Run out of the Internal Taper with respect to the External Taper 0.005 mm

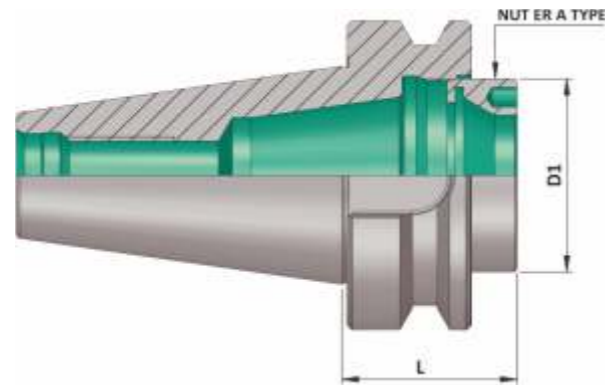

BBT (Short GP Collet Chuck ER - A)

(Balanced to 2.5 G 25000 RPM)

Item Name	Item Code	ISO	Suitable Collet	Collet Capacity	D1	L	Suitable Nut
BBT30 ER 25A 026 AD/2.5G 25000 SL	S10307243500228	30	ER 25	1-16	32	26	ER25A

Accessories:



Collet ER (DIN 6499)
Ref. Page No. 164-168



Tap Collet ER-G
Ref. Page No. 169-171



Q.C.Tap Collet (QCTC)
Ref. Page No. 174-182

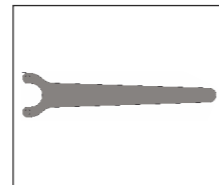

ER A Type Spanner
Ref. Page No. 153

Note: All Dimensions are in mm

**BBT (BT MAS 403)
Weldon Type End Mill Holder (DIN 6359) (WE) (AD)**

Maximum Run out of the Internal Dia with respect to the External Taper 0.005 mm

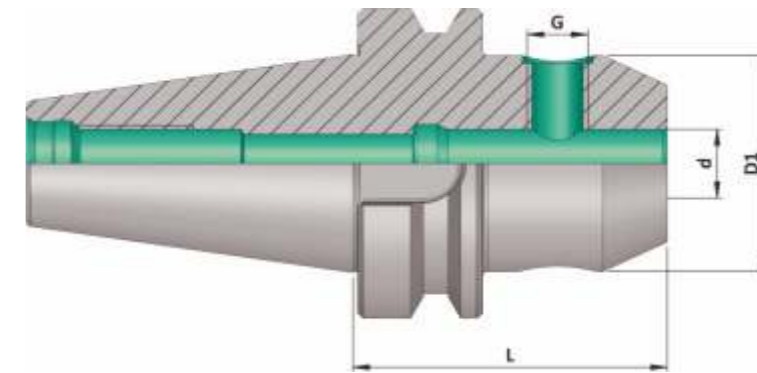

BBT (WE) (AD)

(Balanced to 6.3 G 15000 RPM)

Item Name	Item Code	ISO	d	D1	G	L	Screw Qty.
BBT30 WE06 050 AD/6.3G 15000 SL	S103071111111110	30	6	25	M6	50	1
BBT30 WE08 050 AD/6.3G 15000 SL	S103071121111110	30	8	28	M8	50	1
BBT30 WE10 050 AD/6.3G 15000 SL	S103071131111110	30	10	35	M10	50	1
BBT30 WE12 055 AD/6.3G 15000 SL	S103071141151110	30	12	42	M12	55	1
BBT30 WE14 055 AD/6.3G 15000 SL	S103072581151110	30	14	44	M12	55	1
BBT30 WE16 063 AD/6.3G 15000 SL	S10307115563110	30	16	48	M14	63	1
BBT30 WE18 063 AD/6.3G 15000 SL	S10307259563110	30	18	50	M14	63	1
BBT30 WE20 070 AD/6.3G 15000 SL	S10307116125110	30	20	52	M16	70	1

BBT (WE) (AD) SHORT GP

(Balanced to 2.5 G 25000 RPM)

BBT30 WE06 035 2.5G 25000 SL	S10307111599228	30	6	25	M6	35	1
BBT30 WE08 035 2.5G 25000 SL	S10307112599228	30	8	28	M8	35	1
BBT30 WE10 035 2.5G 25000 SL	S10307113599228	30	10	35	M10	35	1
BBT30 WE12 035 2.5G 25000 SL	S10307114599228	30	12	42	M12	35	1
BBT30 WE14 035 2.5G 25000 SL	S10307258599228	30	14	42	M12	35	1
BBT30 WE16 035 2.5G 25000 SL	S10307115599228	30	16	42	M14	35	1
BBT30 WE18 035 2.5G 25000 SL	S10307259599228	30	18	42	M14	35	1
BBT30 WE20 035 2.5G 25000 SL	S10307116599228	30	20	42	M16	35	1

Note: • All Dimensions are in mm
• These Holders are most suitable for Weldon Type End Mill as per standard DIN 1835 - B

BBT (BT MAS 403)
Weldon Type End Mill Holder (DIN 6359) (WE) (AD)

Maximum Run out of the Internal Dia with respect to the External Taper 0.005 mm

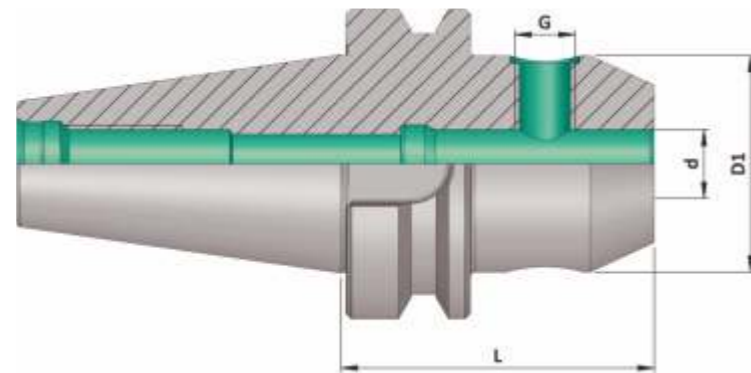

BBT (WE) (AD)

(Balanced to 6.3 G 15000 RPM)

Item Name	Item Code	ISO	d	D1	G	L	Screw Qty.
BBT40 WE06 050 AD/6.3G 15000 SL	S10291111111110	40	6	25	M6	50	1
BBT40 WE06 100 AD/6.3G 15000 SL	S10291111148110	40	6	25	M6	100	1
BBT40 WE06 160 AD/6.3G 15000 SL	S10291111175110	40	6	25	M6	160	1
BBT40 WE08 050 AD/6.3G 15000 SL	S10291112111110	40	8	28	M8	50	1
BBT40 WE08 100 AD/6.3G 15000 SL	S10291112148110	40	8	28	M8	100	1
BBT40 WE08 160 AD/6.3G 15000 SL	S10291112175110	40	8	28	M8	160	1
BBT40 WE10 063 AD/6.3G 15000 SL	S10291113111110	40	10	35	M10	63	1
BBT40 WE10 100 AD/6.3G 15000 SL	S10291113148110	40	10	35	M10	100	1
BBT40 WE10 160 AD/6.3G 15000 SL	S10291113175110	40	10	35	M10	160	1
BBT40 WE12 063 AD/6.3G 15000 SL	S10291114563110	40	12	42	M12	63	1
BBT40 WE12 100 AD/6.3G 15000 SL	S10291114148110	40	12	42	M12	100	1
BBT40 WE12 160 AD/6.3G 15000 SL	S10291114175110	40	12	42	M12	160	1
BBT40 WE14 063 AD/6.3G 15000 SL	S10291258563110	40	14	44	M12	63	1
BBT40 WE14 100 AD/6.3G 15000 SL	S10291258148110	40	14	44	M12	100	1
BBT40 WE14 160 AD/6.3G 15000 SL	S10291258175110	40	14	44	M12	160	1
BBT40 WE16 063 AD/6.3G 15000 SL	S10291115563110	40	16	48	M14	63	1
BBT40 WE16 100 AD/6.3G 15000 SL	S10291115148110	40	16	48	M14	100	1
BBT40 WE16 160 AD/6.3G 15000 SL	S10291115175110	40	16	48	M14	160	1
BBT40 WE18 063 AD/6.3G 15000 SL	S10291259563110	40	18	50	M14	63	1
BBT40 WE18 100 AD/6.3G 15000 SL	S10291259148110	40	18	50	M14	100	1
BBT40 WE18 160 AD/6.3G 15000 SL	S10291259175110	40	18	50	M14	160	1
BBT40 WE20 063 AD/6.3G 15000 SL	S10291116563110	40	20	52	M16	63	1
BBT40 WE20 100 AD/6.3G 15000 SL	S10291116148110	40	20	52	M16	100	1
BBT40 WE20 160 AD/6.3G 15000 SL	S10291116175110	40	20	52	M16	160	1
BBT40 WE25 090 AD/6.3G 15000 SL	S10291117140110	40	25	65	M18X2	90	2
BBT40 WE25 160 AD/6.3G 15000 SL	S10291117175110	40	25	65	M18X2	160	2
BBT40 WE32 100 AD/6.3G 15000 SL	S10291118148110	40	32	72	M20X2	100	2
BBT40 WE32 160 AD/6.3G 15000 SL	S10291118175110	40	32	72	M20X2	160	2
BBT40 WE40 105 AD/6.3G 15000 SL	S10291119152110	40	40	80	M20X2	105	2
BBT40 WE40 160 AD/6.3G 15000 SL	S10291119175110	40	40	80	M20X2	160	2

Note: • All Dimensions are in mm
• These Holders are most suitable for Weldon Type End Mill as per standard DIN 1835 - B

BBT (BT MAS 403)
Weldon Type End Mill Holder (DIN 6359) (WE) (AD)

Maximum Run out of the Internal Dia with respect to the External Taper 0.005 mm

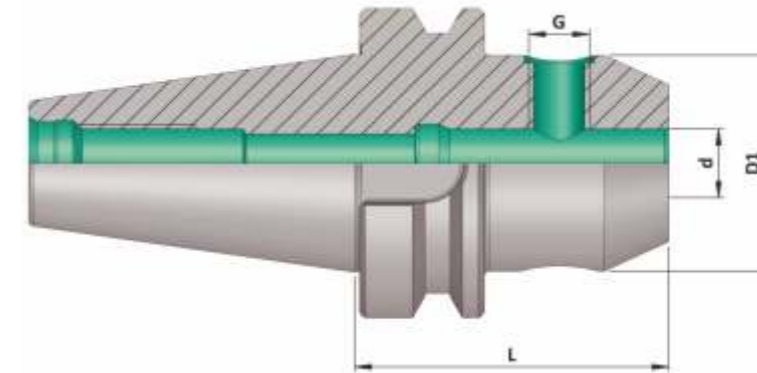

BBT (WE) (AD)

(Balanced to 6.3 G 15000 RPM)

Item Name	Item Code	ISO	d	D1	G	L	Screw Qty.
BBT50 WE06 063 AD/6.3G 15000 SL	S10308111563110	50	6	25	M6	63	1
BBT50 WE06 100 AD/6.3G 15000 SL	S10308111148110	50	6	25	M6	100	1
BBT50 WE06 160 AD/6.3G 15000 SL	S10308111175110	50	6	25	M6	160	1
BBT50 WE08 063 AD/6.3G 15000 SL	S10308112563110	50	8	28	M8	63	1
BBT50 WE08 100 AD/6.3G 15000 SL	S10308112148110	50	8	28	M8	100	1
BBT50 WE08 160 AD/6.3G 15000 SL	S10308112175110	50	8	28	M8	160	1
BBT50 WE10 080 AD/6.3G 15000 SL	S10308113563110	50	10	35	M10	80	1
BBT50 WE10 100 AD/6.3G 15000 SL	S10308113148110	50	10	35	M10	100	1
BBT50 WE10 160 AD/6.3G 15000 SL	S10308113175110	50	10	35	M10	160	1
BBT50 WE12 080 AD/6.3G 15000 SL	S10308114563110	50	12	42	M12	80	1
BBT50 WE12 100 AD/6.3G 15000 SL	S10308114148110	50	12	42	M12	100	1
BBT50 WE12 160 AD/6.3G 15000 SL	S10308114175110	50	12	42	M12	160	1
BBT50 WE14 080 AD/6.3G 15000 SL	S10308258563110	50	14	44	M12	80	1
BBT50 WE14 100 AD/6.3G 15000 SL	S10308258148110	50	14	44	M12	100	1
BBT50 WE14 160 AD/6.3G 15000 SL	S10308258175110	50	14	44	M12	160	1
BBT50 WE16 080 AD/6.3G 15000 SL	S10308115563110	50	16	48	M14	80	1
BBT50 WE16 100 AD/6.3G 15000 SL	S10308115148110	50	16	48	M14	100	1
BBT50 WE16 160 AD/6.3G 15000 SL	S10308115175110	50	16	48	M14	160	1
BBT50 WE18 080 AD/6.3G 15000 SL	S10308259563110	50	18	50	M14	80	1
BBT50 WE18 100 AD/6.3G 15000 SL	S10308259148110	50	18	50	M14	100	1
BBT50 WE18 160 AD/6.3G 15000 SL	S10308259175110	50	18	50	M14	160	1
BBT50 WE20 080 AD/6.3G 15000 SL	S1030811613110	50	20	52	M16	80	1
BBT50 WE20 100 AD/6.3G 15000 SL	S10308116148110	50	20	52	M16	100	1
BBT50 WE20 160 AD/6.3G 15000 SL	S10308116175110	50	20	52	M16	160	1
BBT50 WE25 100 AD/6.3G 15000 SL	S10308117148110	50	25	65	M18X2	100	2
BBT50 WE25 160 AD/6.3G 15000 SL	S10308117175110	50	25	65	M18X2	160	2
BBT50 WE32 105 AD/6.3G 15000 SL	S10308118152110	50	32	72	M20X2	105	2
BBT50 WE32 160 AD/6.3G 15000 SL	S10308118175110	50	32	72	M20X2	160	2
BBT50 WE40 115 AD/6.3G 15000 SL	S10308119159110	50	40	80	M20X2	115	2
BBT50 WE40 160 AD/6.3G 15000 SL	S10308119175110	50	40	80	M20X2	160	2
BBT50 WE50 125 AD/6.3G 15000 SL	S10308120164110	50	50	100	M24 X 2	125	2

Note: • All Dimensions are in mm
• These Holders are most suitable for Weldon Type End Mill as per standard DIN 1835 - B

**BBT (BT MAS 403)
Face Mill Holder (DIN 6357) (FMH) (AD)**

Maximum Run out of the External Dia with respect to the External Taper 0.005 mm

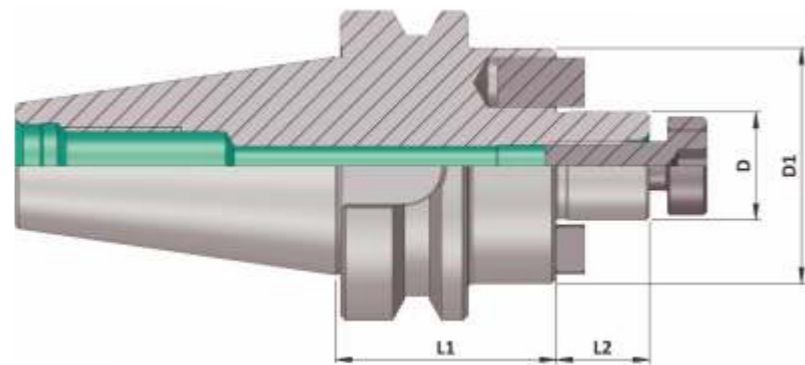

BBT (FMH) (AD)

(Balanced to 2.5 G 25000 RPM)

Item Name	Item Code	ISO	D	D1	L1	L2
BBT30 FMH16 035 AD/2.5G 25000 SL S.P.S	S10307126104232	30	16	38	35	17
BBT30 FMH22 040 AD/2.5G 25000 SL S.P.S	S10307127106232	30	22	48	40	19
BBT30 FMH27 040 AD/2.5G 25000 SL S.P.S	S10307128106232	30	27	58	40	21
BBT40 FMH16 045 AD/2.5G 25000 SL S.P.S	S10291126108232	40	16	38	45	17
BBT40 FMH16 100 AD/2.5G 25000 SL S.P.S	S10291126148232	40	16	38	100	17
BBT40 FMH16 160 AD/2.5G 25000 SL S.P.S	S10291126175232	40	16	38	160	17
BBT40 FMH22 045 AD/2.5G 25000 SL S.P.S	S10291127108232	40	22	48	45	19
BBT40 FMH22 100 AD/2.5G 25000 SL S.P.S	S10291127148232	40	22	48	100	19
BBT40 FMH22 160 AD/2.5G 25000 SL S.P.S	S10291127175232	40	22	48	160	19
BBT40 FMH27 045 AD/2.5G 25000 SL S.P.S	S10291128108232	40	27	58	45	21
BBT40 FMH27 100 AD/2.5G 25000 SL S.P.S	S10291128148232	40	27	58	100	21
BBT40 FMH27 160 AD/2.5G 25000 SL S.P.S	S10291128175232	40	27	58	160	21
BBT40 FMH32 050 AD/2.5G 25000 SL S.P.S	S10291129111232	40	32	78	50	24
BBT40 FMH32 100 AD/2.5G 25000 SL S.P.S	S10291129148232	40	32	78	100	24
BBT40 FMH32 160 AD/2.5G 25000 SL S.P.S	S10291129175232	40	32	78	160	24
BBT40 FMH40 055 AD/2.5G 25000 SL S.P.S	S10291130115232	40	40	88	55	27
BBT40 FMH40 100 AD/2.5G 25000 SL S.P.S	S10291130148232	40	40	88	100	27
BBT40 FMH40 160 AD/2.5G 25000 SL S.P.S	S10291130175232	40	40	88	160	27
BBT50 FMH16 060 AD/2.5G 25000 SL S.P.S	S10308126117232	50	16	38	60	17
BBT50 FMH16 100 AD/2.5G 25000 SL S.P.S	S10308126148232	50	16	38	100	17
BBT50 FMH16 160 AD/2.5G 25000 SL S.P.S	S10308126175232	50	16	38	160	17
BBT50 FMH22 060 AD/2.5G 25000 SL S.P.S	S10308127117232	50	22	48	60	19
BBT50 FMH22 100 AD/2.5G 25000 SL S.P.S	S10308127148232	50	22	48	100	19
BBT50 FMH22 160 AD/2.5G 25000 SL S.P.S	S10308127175232	50	22	48	160	19
BBT50 FMH27 060 AD/2.5G 25000 SL S.P.S	S10308128117232	50	27	58	60	21
BBT50 FMH27 100 AD/2.5G 25000 SL S.P.S	S10308128148232	50	27	58	100	21
BBT50 FMH27 160 AD/2.5G 25000 SL S.P.S	S10308128175232	50	27	58	160	21
BBT50 FMH32 060 AD/2.5G 25000 SL S.P.S	S10308129117232	50	32	78	60	24
BBT50 FMH32 100 AD/2.5G 25000 SL S.P.S	S10308129148232	50	32	78	100	24
BBT50 FMH32 160 AD/2.5G 25000 SL S.P.S	S10308129175232	50	32	78	160	24
BBT50 FMH40 060 AD/2.5G 25000 SL S.P.S	S10308130117232	50	40	88	60	27
BBT50 FMH40 100 AD/2.5G 25000 SL S.P.S	S10308130148232	50	40	88	100	27
BBT50 FMH40 160 AD/2.5G 25000 SL S.P.S	S10308130175232	50	40	88	160	27

Note: All Dimensions are in mm

**BBT (BT MAS 403)
Face Mill Holder (Through Coolant) (DIN 6357) (FMH-K) (AD)**

Maximum Run out of the External Dia with respect to the External Taper 0.005 mm

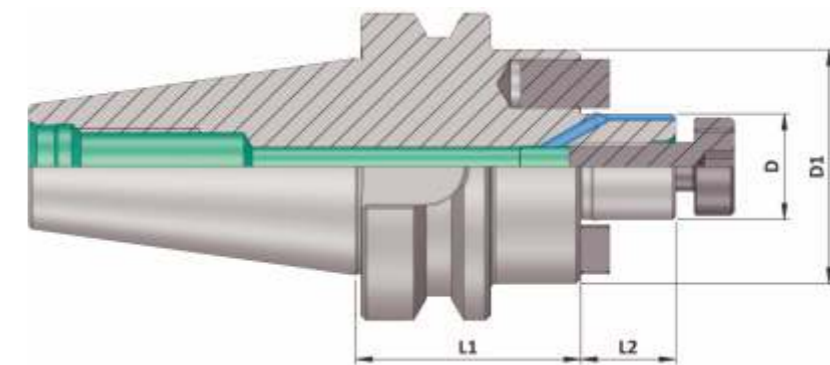

BBT (FMH - K) (AD)

(Balanced to 2.5 G 25000 RPM)

Item Name	Item Code	ISO	D	D1	L1	L2
BBT40 FMH-K16 045 AD/2.5G 25000 SL S.P.S	S10291131108232	40	16	38	45	17
BBT40 FMH-K16 100 AD/2.5G 25000 SL S.P.S	S10291131148232	40	16	38	100	17
BBT40 FMH-K16 160 AD/2.5G 25000 SL S.P.S	S10291131175232	40	16	38	160	17
BBT40 FMH-K22 045 AD/2.5G 25000 SL S.P.S	S10291132108232	40	22	48	45	19
BBT40 FMH-K22 100 AD/2.5G 25000 SL S.P.S	S10291132148232	40	22	48	100	19
BBT40 FMH-K22 160 AD/2.5G 25000 SL S.P.S	S10291132175232	40	22	48	160	19
BBT40 FMH-K27 045 AD/2.5G 25000 SL S.P.S	S10291133108232	40	27	58	45	21
BBT40 FMH-K27 100 AD/2.5G 25000 SL S.P.S	S10291133148232	40	27	58	100	21
BBT40 FMH-K27 160 AD/2.5G 25000 SL S.P.S	S10291133175232	40	27	58	160	21
BBT40 FMH-K32 050 AD/2.5G 25000 SL S.P.S	S10291134111232	40	32	78	50	24
BBT40 FMH-K32 100 AD/2.5G 25000 SL S.P.S	S10291134148232	40	32	78	100	24
BBT40 FMH-K32 160 AD/2.5G 25000 SL S.P.S	S10291134175232	40	32	78	160	24
BBT40 FMH-K40 055 AD/2.5G 25000 SL S.P.S	S10291576115232	40	40	88	55	27
BBT40 FMH-K40 100 AD/2.5G 25000 SL S.P.S	S10291576148232	40	40	88	100	27
BBT40 FMH-K40 160 AD/2.5G 25000 SL S.P.S	S10291576175232	40	40	88	160	27

BBT50 FMH-K16 060 AD/2.5G 25000 SL S.P.S	S10308131117232	50	16	38	60	17
BBT50 FMH-K16 100 AD/2.5G 25000 SL S.P.S	S10308131148232	50	16	38	100	17
BBT50 FMH-K16 160 AD/2.5G 25000 SL S.P.S	S10308131175232	50	16	38	160	17
BBT50 FMH-K22 060 AD/2.5G 25000 SL S.P.S	S10308132117232	50	22	48	60	19
BBT50 FMH-K22 100 AD/2.5G 25000 SL S.P.S	S10308132148232	50	22	48	100	19
BBT50 FMH-K22 160 AD/2.5G 25000 SL S.P.S	S10308132175232	50	22	48	160	19
BBT50 FMH-K27 060 AD/2.5G 25000 SL S.P.S	S10308133117232	50	27	58	60	21
BBT50 FMH-K27 100 AD/2.5G 25000 SL S.P.S	S10308133148232	50	27	58	100	21
BBT50 FMH-K27 160 AD/2.5G 25000 SL S.P.S	S10308133175232	50	27	58	160	21
BBT50 FMH-K32 060 AD/2.5G 25000 SL S.P.S	S10308134117232	50	32	78	60	24
BBT50 FMH-K32 100 AD/2.5G 25000 SL S.P.S	S10308134148232	50	32	78	100	24
BBT50 FMH-K32 160 AD/2.5G 25000 SL S.P.S	S10308134175232	50	32	78	160	24
BBT50 FMH-K40 060 AD/2.5G 25000 SL S.P.S	S10308576117232	50	40	88	60	27
BBT50 FMH-K40 100 AD/2.5G 25000 SL S.P.S	S10308576148232	50	40	88	100	27
BBT50 FMH-K40 160 AD/2.5G 25000 SL S.P.S	S10308576175232	50	40	88	160	27

Note: All Dimensions are in mm

**BBT (BT MAS 403)
Boring Bar Blank**

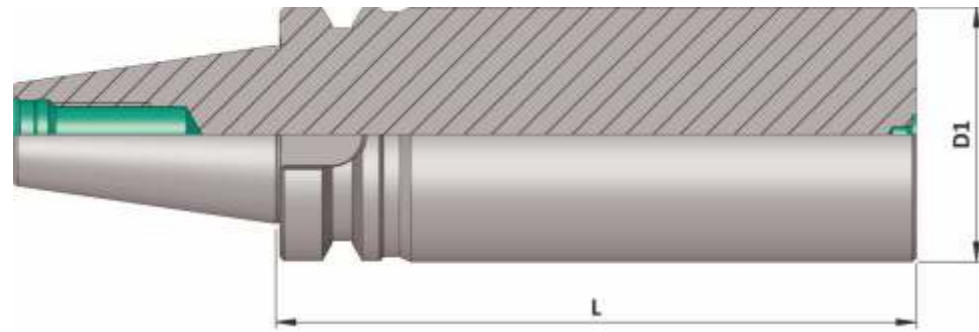

BBT (Boring Bar Blank)

Item Name	Item Code	ISO	D1	L
BBT40 BORING BAR BLANK DIA 63.5 L 120	S10291173498127	40	63.5	120
BBT40 BORING BAR BLANK DIA 63.5 L 160	S10291173330127	40	63.5	160
BBT40 BORING BAR BLANK DIA 63.5 L 250	S1029117325612	40	63.5	250
BBT50 BORING BAR BLANK DIA 80.0 L 160	S10308264330127	50	80	160
BBT50 BORING BAR BLANK DIA 80.0 L 200	S10308264237127	50	80	200
BBT50 BORING BAR BLANK DIA 80.0 L 300	S10308264257127	50	80	300
BBT50 BORING BAR BLANK DIA 97.0 L 315	S10308265329127	50	97	315

**BBT (BT MAS 403)
NC Drill Chuck (NCDC)**

Maximum Run out on the Mandrell with respect to the External Taper 0.050 mm

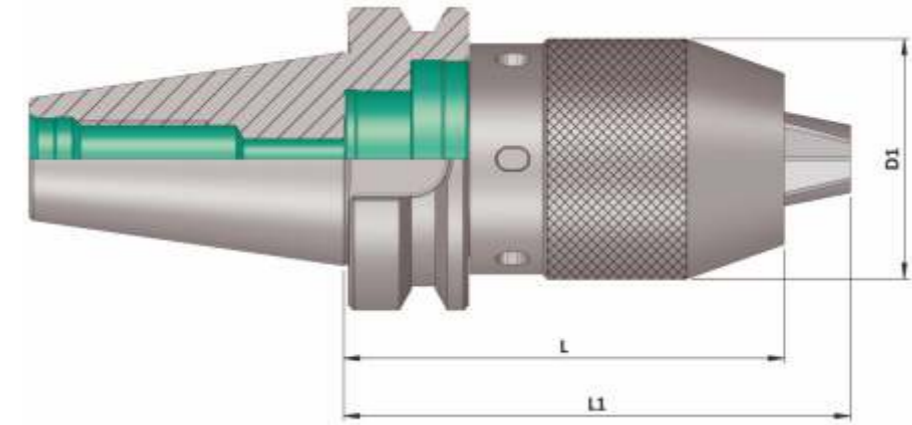

BBT (NCDC)

Item Name	Item Code	ISO	D1	L	L1
BBT30 NCDC1-13 112.5	S10307167345127	30	50	112.5	125
BBT40 NCDC1-13 092.5	S10291167142127	40	50	92.5	105
BBT50 NCDC1-13 107.5	S10308167154127	50	50	107.5	120

Accessories:

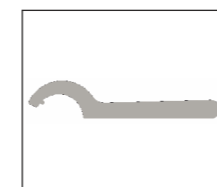

NCDC Spanner
Ref. Page No. 154

Note: All Dimensions are in mm

Note: All Dimensions are in mm

Die & Mould Chuck (DMC)

◆ **Features :**

- Small outside diameter.
- Best suitable for Die & Mould Industry.
- Most suitable for machining of cavities difficult to reach.
- High precision Runout < 0.005mm (4xd).
- All 'Sigma' Die & Mould Chucks are subjected to Sub-zero treatment (-90° C). This treatment helps to prevent the holders from deformation for many years & hence increases the life.

◆ **Capacity :**

- DMC 06 (3mm to 6mm)
- DMC 08 (3mm to 8 mm)
- DMC 10 (3mm to 10mm)

◆ **Available In Mountings :**

- HSK-A (DIN 69893-1)
- BT (MAS 403) (DIN ISO 7388 -2)
- BBT (MAS 403)
- SK (DIN 69871) (DIN ISO 7388 - 1)
- Cylindrical Shank

◆ **Balancing :**

- Balanced To 2.5 G 25000 RPM



BBT (BT MAS 403) Die & Mould Chuck (DMC)

Maximum Run out of the Internal Taper with respect to the External Taper < 0.005 mm

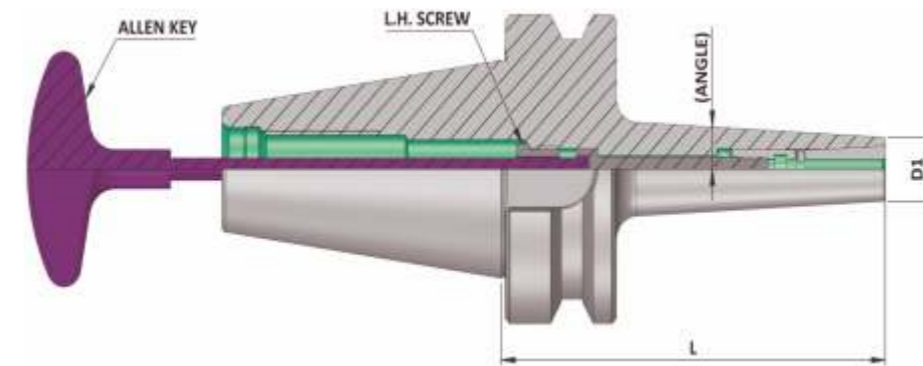

BBT (MAS 403)
Holders

BBT (DMC)

(Balanced to 2.5 G 25000 RPM)

Item Name	Item Code	ISO	Gripping Range	D1	L	Angle	Suitable Collet	Screw	Allen Key
BBT30 DMC 06 090 AD/2.5G 25000 SL	S10307161140228	30	3 - 6	13	90	3	DMC-6	M5	4X200
BBT40 DMC 06 060 AD/2.5G 25000 SL	S10291161117228	40	3 - 6	13	60	3	DMC-6	M5	4X200
BBT40 DMC 06 090 AD/2.5G 25000 SL	S10291161140228	40	3 - 6	13	90	3	DMC-6	M5	4X200
BBT40 DMC 06 120 AD/2.5G 25000 SL	S10291161162228	40	3 - 6	13	120	3	DMC-6	M5	4X200
BBT40 DMC 06 160 AD/2.5G 25000 SL	S10291161175228	40	3 - 6	13	160	3	DMC-6	M5	4X200
BBT40 DMC 08 090 AD/2.5G 25000 SL	S10291162140228	40	3 - 8	22	90	3	DMC-8	M6	5X200
BBT40 DMC 08 120 AD/2.5G 25000 SL	S10291162162228	40	3 - 8	22	120	3	DMC-8	M6	5X200
BBT40 DMC 10 090 AD/2.5G 25000 SL	S10291163140228	40	3 - 10	28	90	-	DMC-10	M8	6X200
BBT40 DMC 10 120 AD/2.5G 25000 SL	S10291163162228	40	3 - 10	28	120	-	DMC-10	M8	6X200
BBT50 DMC 10 150 AD/2.5G 25000 SL	S10308163173228	50	3 - 10	28	150	-	DMC-10	M8	6X200

Accessories:



DMC Collet
Ref. Page No. 172

Note: All Dimensions are in mm

Power Milling Chuck (PMC)

◆ Features:

- 'Sigma' Power Milling Chuck is Very Rigid & Precision.
- It is best for Drilling, Reaming & Milling Operations.
- The tool runs true less than 5 micron on 2D. Hence the tool life increases drastically.
- It's Unibody construction reduces the vibrations, This also helps to increase the tool life.
- All 'Sigma' Power Milling Chucks are subjected to sub-zero treatment (-90° C). This treatment helps to prevent the holders from deformation for many years & hence increases the life.

◆ Available In Mountings:

- HSK-A (DIN 69893-1)
- BT (MAS 403) (DIN ISO 7388-2)
- BBT (MAS 403)
- SK (DIN 69871) (DIN ISO 7388-1)

◆ Balancing:

- Balanced To 6.3 G 15000 RPM



BBT (BT MAS 403) Power Milling Chuck (PMC)

Maximum Run out of the Internal Dia with respect to the External Taper 0.005 mm

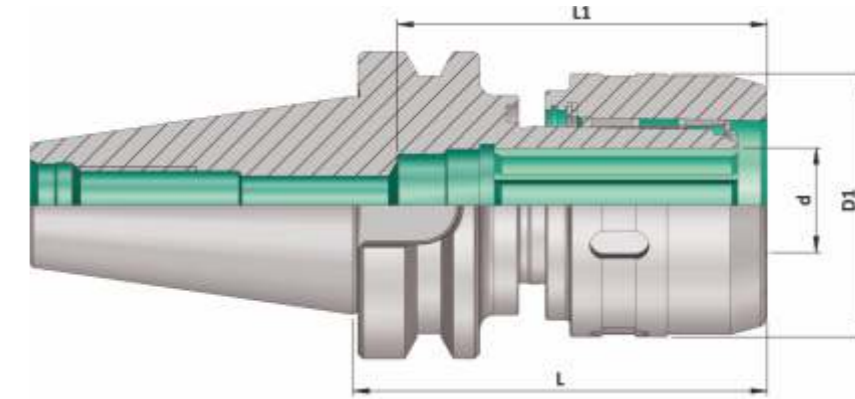

BBT (PMC)

(Balanced to 6.3 G 15000 RPM)

Item Name	Item Code	ISO	d	D1	L	L1
BBT30 C20 075 AD/6.3G 15000 SL	S10307445127110	30	20	54	75	70
BBT40 C20 080 AD/6.3G 15000 SL	S10291445131110	40	20	54	80	70
BBT40 C32 090 AD/6.3G 15000 SL	S10291446140110	40	32	72	90	100
BBT50 C20 105 AD/6.3G 15000 SL	S10308445152110	50	20	54	105	70
BBT50 C32 105 AD/6.3G 15000 SL	S10308446152110	50	32	72	105	100

Accessories:



Reduction Sleeve (RS)
Ref. Page No. 173

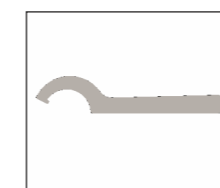

PMC Spanner
Ref. Page No. 154

Note: All Dimensions are in mm

Shrink Fit Holder 4.5 Degree (SFH 4.5°)

◆ Features :

- For Mounting Of Carbide Drills, End Mills etc.
- Easy to Reach at Deep Cavities.
- Best T. I. R. & Rigidity during long working life, Result of in house Reasearch & Development & special Heat Treatment.

◆ Available In Mountings :

- HSK-A (DIN 69893-1)
- BT (MAS 403) (DIN ISO 7388 - 2)
- BBT (MAS 403)
- SK (DIN 69871) (DIN ISO 7388 - 1)

◆ Balancing :

- Balanced To 2.5 G 25000 RPM



BBT (BT MAS 403) Shrink Fit Holder (SFH 4.5°) (AD)

Maximum Run out of the Internal Dia with respect to the External Taper 0.003 mm

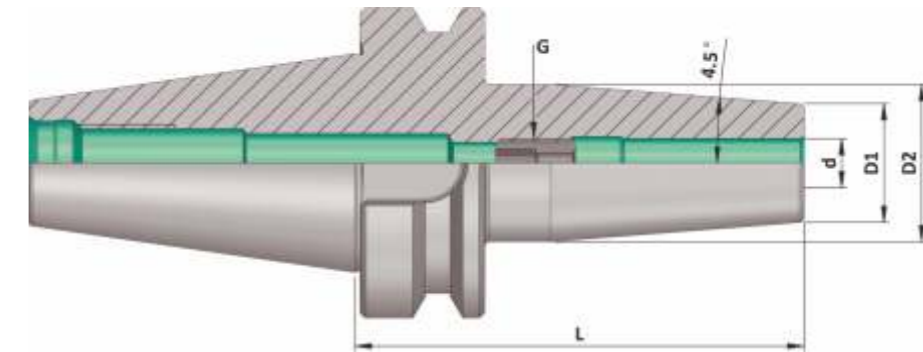

BBT (SFH 4.5°) (AD)

(Balanced to 2.5 G 25000 RPM)

Item Name	Item Code	ISO	d	D1	D2	G	L
BBT30 SFH03 080 AD/2.5G 25000 SL	S10307274131228	30	3	10	20	-	80
BBT30 SFH04 080 AD/2.5G 25000 SL	S10307275131228	30	4	15	22	-	80
BBT30 SFH05 080 AD/2.5G 25000 SL	S10307276131228	30	5	15	22	-	80
BBT30 SFH06 080 AD/2.5G 25000 SL	S10307277131228	30	6	21	27	M5	80
BBT30 SFH08 080 AD/2.5G 25000 SL	S10307285131228	30	8	21	27	M6	80
BBT30 SFH10 080 AD/2.5G 25000 SL	S10307279131228	30	10	24	31	M8	80
BBT30 SFH12 080 AD/2.5G 25000 SL	S10307280131228	30	12	24	31	M10	80
BBT30 SFH14 080 AD/2.5G 25000 SL	S10307284131228	30	14	27	34	M10	80
BBT30 SFH16 080 AD/2.5G 25000 SL	S10307281131228	30	16	27	34	M12	80
BBT30 SFH18 080 AD/2.5G 25000 SL	S10307282131228	30	18	33	40	M12	80
BBT30 SFH20 080 AD/2.5G 25000 SL	S10307283131228	30	20	33	40	M16	80

Note: All Dimensions are in mm

**BBT (BT MAS 403)
Shrink Fit Holder (SFH 4.5°) (AD)**

Maximum Run out of the Internal Dia with respect to the External Taper 0.003 mm

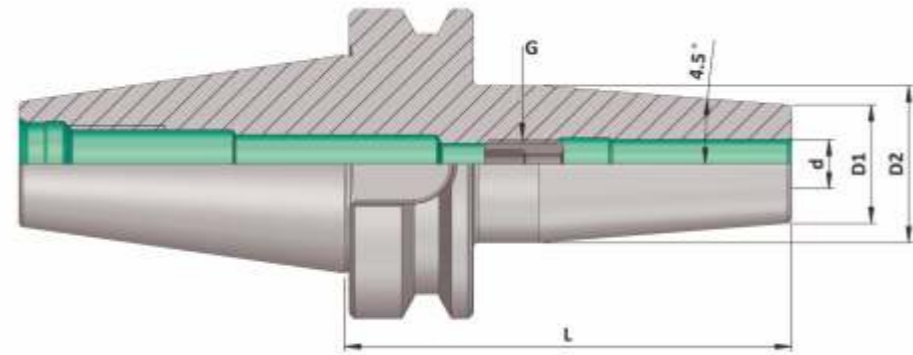

BBT (SFH 4.5°) (AD)

(Balanced to 2.5 G 25000 RPM)

Item Name	Item Code	ISO	d	D1	D2	G	L
BBT40 SFH03 090 AD/2.5G 25000 SL	S10291274140228	40	3	10	20	-	90
BBT40 SFH03 120 AD/2.5G 25000 SL	S10291274162228	40	3	10	20	-	120
BBT40 SFH03 160 AD/2.5G 25000 SL	S10291274175228	40	3	10	20	-	160
BBT40 SFH04 090 AD/2.5G 25000 SL	S10291275140228	40	4	15	22	-	90
BBT40 SFH04 120 AD/2.5G 25000 SL	S10291275162228	40	4	15	22	-	120
BBT40 SFH04 160 AD/2.5G 25000 SL	S10291275175228	40	4	15	22	-	160
BBT40 SFH05 090 AD/2.5G 25000 SL	S10291276140228	40	5	15	22	-	90
BBT40 SFH05 120 AD/2.5G 25000 SL	S10291276162228	40	5	15	22	-	120
BBT40 SFH05 160 AD/2.5G 25000 SL	S10291276175228	40	5	15	22	-	160
BBT40 SFH06 090 AD/2.5G 25000 SL	S10291277140228	40	6	21	27	M5	90
BBT40 SFH06 120 AD/2.5G 25000 SL	S10291277162228	40	6	21	27	M5	120
BBT40 SFH06 160 AD/2.5G 25000 SL	S10291277175228	40	6	21	27	M5	160
BBT40 SFH08 090 AD/2.5G 25000 SL	S10291285140228	40	8	21	27	M6	90
BBT40 SFH08 120 AD/2.5G 25000 SL	S10291285162228	40	8	21	27	M6	120
BBT40 SFH08 160 AD/2.5G 25000 SL	S10291285175228	40	8	21	27	M6	160
BBT40 SFH10 090 AD/2.5G 25000 SL	S10291279140228	40	10	24	31	M8	90
BBT40 SFH10 120 AD/2.5G 25000 SL	S10291279162228	40	10	24	31	M8	120
BBT40 SFH10 160 AD/2.5G 25000 SL	S10291279175228	40	10	24	31	M8	160
BBT40 SFH12 090 AD/2.5G 25000 SL	S10291280140228	40	12	24	31	M10	90
BBT40 SFH12 120 AD/2.5G 25000 SL	S10291280162228	40	12	24	31	M10	120
BBT40 SFH12 160 AD/2.5G 25000 SL	S10291280175228	40	12	24	31	M10	160

**BBT (BT MAS 403)
Shrink Fit Holder (SFH 4.5°) (AD)**

Maximum Run out of the Internal Dia with respect to the External Taper 0.003 mm

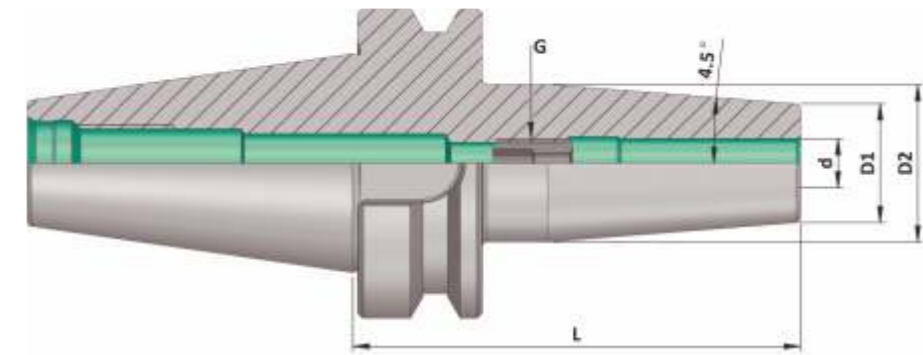

BBT (SFH 4.5°) (AD)

(Balanced to 2.5 G 25000 RPM)

Item Name	Item Code	ISO	d	D1	D2	G	L
BBT40 SFH14 090 AD/2.5G 25000 SL	S10291284140228	40	14	27	34	M10	90
BBT40 SFH14 120 AD/2.5G 25000 SL	S10291284162228	40	14	27	34	M10	120
BBT40 SFH14 160 AD/2.5G 25000 SL	S10291284175228	40	14	27	34	M10	160
BBT40 SFH16 090 AD/2.5G 25000 SL	S10291281140228	40	16	27	34	M12	90
BBT40 SFH16 120 AD/2.5G 25000 SL	S10291281162228	40	16	27	34	M12	120
BBT40 SFH16 160 AD/2.5G 25000 SL	S10291281175228	40	16	27	34	M12	160
BBT40 SFH18 090 AD/2.5G 25000 SL	S10291282140228	40	18	33	40	M12	90
BBT40 SFH18 120 AD/2.5G 25000 SL	S10291282162228	40	18	33	40	M12	120
BBT40 SFH18 160 AD/2.5G 25000 SL	S10291282175228	40	18	33	40	M12	160
BBT40 SFH20 090 AD/2.5G 25000 SL	S10291283148228	40	20	33	40	M16	90
BBT40 SFH20 120 AD/2.5G 25000 SL	S10291283162228	40	20	33	40	M16	120
BBT40 SFH20 160 AD/2.5G 25000 SL	S10291283175228	40	20	33	40	M16	160
BBT40 SFH25 100 AD/2.5G 25000 SL	S10291287156228	40	25	44	53	M16	100
BBT40 SFH25 120 AD/2.5G 25000 SL	S10291287162228	40	25	44	53	M16	120
BBT40 SFH25 160 AD/2.5G 25000 SL	S10291287175228	40	25	44	53	M16	160
BBT40 SFH32 100 AD/2.5G 25000 SL	S10291288156228	40	32	44	53	M16	100
BBT40 SFH32 120 AD/2.5G 25000 SL	S10291288162228	40	32	44	53	M16	120
BBT40 SFH32 160 AD/2.5G 25000 SL	S10291288175228	40	32	44	53	M16	160

**BBT (BT MAS 403)
Shrink Fit Holder (SFH 4.5°) (AD)**

Maximum Run out of the Internal Dia with respect to the External Taper 0.003 mm

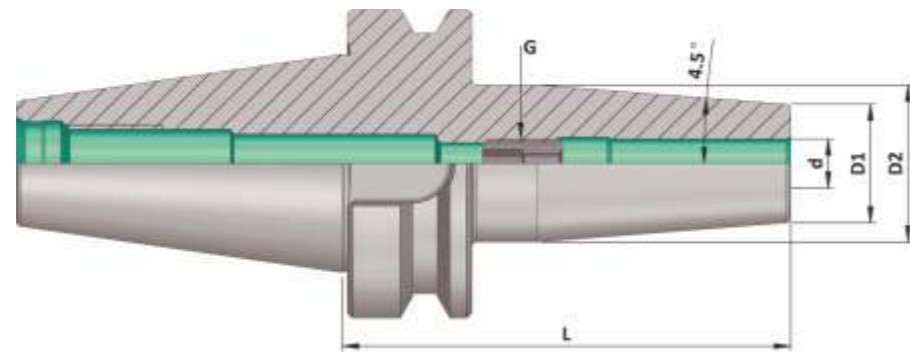

BBT (SFH 4.5°) (AD)

(Balanced to 2.5 G 25000 RPM)

Item Name	Item Code	ISO	d	D1	D2	G	L
BBT50 SFH03 100 AD/2.5G 25000 SL	S10308274148228	50	3	10	20	-	100
BBT50 SFH03 120 AD/2.5G 25000 SL	S10308274162228	50	3	10	20	-	120
BBT50 SFH03 160 AD/2.5G 25000 SL	S10308274175228	50	3	10	20	-	160
BBT50 SFH04 100 AD/2.5G 25000 SL	S10308275148228	50	4	15	22	-	100
BBT50 SFH04 120 AD/2.5G 25000 SL	S10308275162228	50	4	15	22	-	120
BBT50 SFH04 160 AD/2.5G 25000 SL	S10308275175228	50	4	15	22	-	160
BBT50 SFH05 100 AD/2.5G 25000 SL	S10308276148228	50	5	15	22	-	100
BBT50 SFH05 120 AD/2.5G 25000 SL	S10308276162228	50	5	15	22	-	120
BBT50 SFH05 160 AD/2.5G 25000 SL	S10308276175228	50	5	15	22	-	160
BBT50 SFH06 100 AD/2.5G 25000 SL	S10308277148228	50	6	21	27	M5	100
BBT50 SFH06 120 AD/2.5G 25000 SL	S10308277162228	50	6	21	27	M5	120
BBT50 SFH06 160 AD/2.5G 25000 SL	S10308277175228	50	6	21	27	M5	160
BBT50 SFH08 100 AD/2.5G 25000 SL	S10308285148228	50	8	21	27	M6	100
BBT50 SFH08 120 AD/2.5G 25000 SL	S10308285162228	50	8	21	27	M6	120
BBT50 SFH08 160 AD/2.5G 25000 SL	S10308285175228	50	8	21	27	M6	160
BBT50 SFH10 100 AD/2.5G 25000 SL	S10308279148228	50	10	24	31	M8	100
BBT50 SFH10 120 AD/2.5G 25000 SL	S10308279162228	50	10	24	31	M8	120
BBT50 SFH10 160 AD/2.5G 25000 SL	S10308279175228	50	10	24	31	M8	160
BBT50 SFH12 100 AD/2.5G 25000 SL	S10308280148228	50	12	24	31	M10	100
BBT50 SFH12 120 AD/2.5G 25000 SL	S10308280162228	50	12	24	31	M10	120
BBT50 SFH12 160 AD/2.5G 25000 SL	S10308280175228	50	12	24	31	M10	160

**BBT (BT MAS 403)
Shrink Fit Holder (SFH 4.5°) (AD)**

Maximum Run out of the Internal Dia with respect to the External Taper 0.003 mm

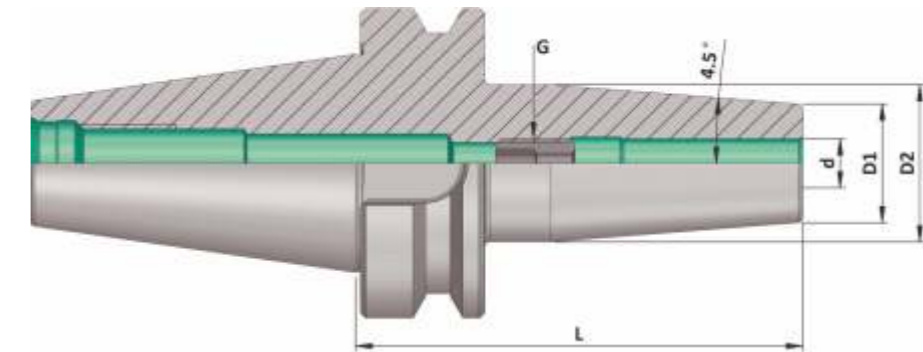

BBT (SFH 4.5°) (AD)

(Balanced to 2.5 G 25000 RPM)

Item Name	Item Code	ISO	d	D1	D2	G	L
BBT50 SFH14 100 AD/2.5G 25000 SL	S10308284148228	50	14	27	34	M10	100
BBT50 SFH14 120 AD/2.5G 25000 SL	S10308284162228	50	14	27	34	M10	120
BBT50 SFH14 160 AD/2.5G 25000 SL	S10308284175228	50	14	27	34	M10	160
BBT50 SFH16 100 AD/2.5G 25000 SL	S10308281148228	50	16	27	34	M12	100
BBT50 SFH16 120 AD/2.5G 25000 SL	S10308281162228	50	16	27	34	M12	120
BBT50 SFH16 160 AD/2.5G 25000 SL	S10308281175228	50	16	27	34	M12	160
BBT50 SFH18 100 AD/2.5G 25000 SL	S10308282148228	50	18	33	40	M12	100
BBT50 SFH18 120 AD/2.5G 25000 SL	S10308282162228	50	18	33	40	M12	120
BBT50 SFH18 160 AD/2.5G 25000 SL	S10308282175228	50	18	33	40	M12	160
BBT50 SFH20 100 AD/2.5G 25000 SL	S10308283148228	50	20	33	40	M16	100
BBT50 SFH20 120 AD/2.5G 25000 SL	S10308283162228	50	20	33	40	M16	120
BBT50 SFH20 160 AD/2.5G 25000 SL	S10308283175228	50	20	33	40	M16	160
BBT50 SFH25 110 AD/2.5G 25000 SL	S10308287156228	50	25	44	53	M16	110
BBT50 SFH25 120 AD/2.5G 25000 SL	S10308287162228	50	25	44	53	M16	120
BBT50 SFH25 160 AD/2.5G 25000 SL	S10308287175228	50	25	44	53	M16	160
BBT50 SFH32 110 AD/2.5G 25000 SL	S10308288156228	50	32	44	53	M16	110
BBT50 SFH32 120 AD/2.5G 25000 SL	S10308288162228	50	32	44	53	M16	120
BBT50 SFH32 160 AD/2.5G 25000 SL	S10308288175228	50	32	44	53	M16	160

BBT (BT MAS 403)
Shrink Fit Holder (Face Coolant Channel)
(SFH 4.5°) (FCC)

Maximum Run out of the Internal Dia with respect to the External Taper 0.003 mm

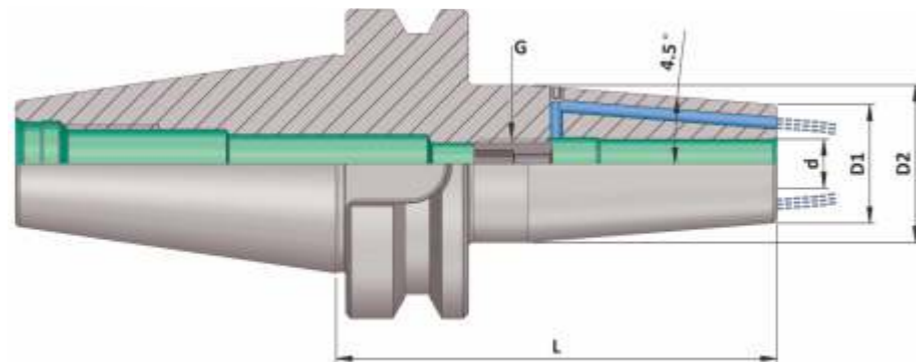

BBT (SFH 4.5°) (FCC)

(Balanced to 2.5 G 25000 RPM)

Item Name	Item Code	ISO	d	D1	D2	G	L
BBT30 SFH03 080 FCC 2.5G 25000 SL	S10307274131256	30	3	10	20	-	80
BBT30 SFH04 080 FCC 2.5G 25000 SL	S10307275131256	30	4	15	22	-	80
BBT30 SFH05 080 FCC 2.5G 25000 SL	S10307276131256	30	5	15	22	-	80
BBT30 SFH06 080 FCC 2.5G 25000 SL	S10307277131256	30	6	21	27	M5	80
BBT30 SFH08 080 FCC 2.5G 25000 SL	S10307285131256	30	8	21	27	M6	80
BBT30 SFH10 080 FCC 2.5G 25000 SL	S10307279131256	30	10	24	31	M8	80
BBT30 SFH12 080 FCC 2.5G 25000 SL	S10307280131256	30	12	24	31	M10	80
BBT30 SFH14 080 FCC 2.5G 25000 SL	S10307284131256	30	14	27	34	M10	80
BBT30 SFH16 080 FCC 2.5G 25000 SL	S10307281131256	30	16	27	34	M12	80
BBT30 SFH18 080 FCC 2.5G 25000 SL	S10307282131256	30	18	33	40	M12	80
BBT30 SFH20 080 FCC 2.5G 25000 SL	S10307283131256	30	20	33	40	M16	80

BBT (BT MAS 403)
Shrink Fit Holder (Face Coolant Channel)
(SFH 4.5°) (FCC)

Maximum Run out of the Internal Dia with respect to the External Taper 0.003 mm

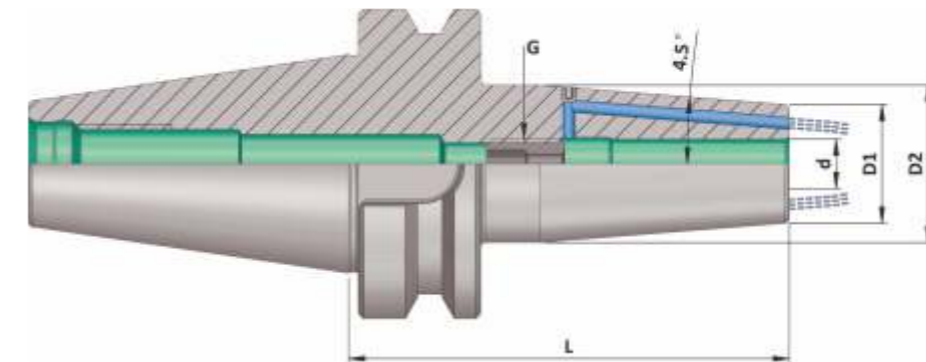

BBT (SFH 4.5°) (FCC)

(Balanced to 2.5 G 25000 RPM)

Item Name	Item Code	ISO	d	D1	D2	G	L
BBT40 SFH03 090 FCC 2.5G 25000 SL	S10291274140256	40	3	10	20	-	90
BBT40 SFH03 120 FCC 2.5G 25000 SL	S10291274162256	40	3	10	20	-	120
BBT40 SFH03 160 FCC 2.5G 25000 SL	S10291274175256	40	3	10	20	-	160
BBT40 SFH04 090 FCC 2.5G 25000 SL	S10291275140256	40	4	15	22	-	90
BBT40 SFH04 120 FCC 2.5G 25000 SL	S10291275162256	40	4	15	22	-	120
BBT40 SFH04 160 FCC 2.5G 25000 SL	S10291275175256	40	4	15	22	-	160
BBT40 SFH05 090 FCC 2.5G 25000 SL	S10291276140256	40	5	15	22	-	90
BBT40 SFH05 120 FCC 2.5G 25000 SL	S10291276162256	40	5	15	22	-	120
BBT40 SFH05 160 FCC 2.5G 25000 SL	S10291276175256	40	5	15	22	-	160
BBT40 SFH06 090 FCC 2.5G 25000 SL	S10291277140256	40	6	21	27	M5	90
BBT40 SFH06 120 FCC 2.5G 25000 SL	S10291277162256	40	6	21	27	M5	120
BBT40 SFH06 160 FCC 2.5G 25000 SL	S10291277175256	40	6	21	27	M5	160
BBT40 SFH08 090 FCC 2.5G 25000 SL	S10291285140256	40	8	21	27	M6	90
BBT40 SFH08 120 FCC 2.5G 25000 SL	S10291285162256	40	8	21	27	M6	120
BBT40 SFH08 160 FCC 2.5G 25000 SL	S10291285175256	40	8	21	27	M6	160
BBT40 SFH10 090 FCC 2.5G 25000 SL	S10291279140256	40	10	24	31	M8	90
BBT40 SFH10 120 FCC 2.5G 25000 SL	S10291279162256	40	10	24	31	M8	120
BBT40 SFH10 160 FCC 2.5G 25000 SL	S10291279175256	40	10	24	31	M8	160
BBT40 SFH12 090 FCC 2.5G 25000 SL	S10291280140256	40	12	24	31	M10	90
BBT40 SFH12 120 FCC 2.5G 25000 SL	S10291280162256	40	12	24	31	M10	120
BBT40 SFH12 160 FCC 2.5G 25000 SL	S10291280175256	40	12	24	31	M10	160

**BBT (BT MAS 403)
Shrink Fit Holder (Face Coolant Channel)
(SFH 4.5°) (FCC)**

Maximum Run out of the Internal Dia with respect to the External Taper 0.003 mm

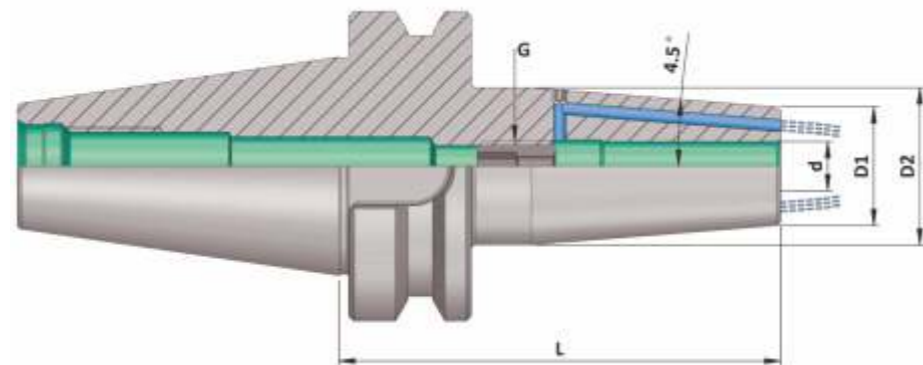

BBT (SFH 4.5°) (FCC)

(Balanced to 2.5 G 25000 RPM)

Item Name	Item Code	ISO	d	D1	D2	G	L
BBT40 SFH14 090 FCC 2.5G 25000 SL	S10291284140256	40	14	27	34	M10	90
BBT40 SFH14 120 FCC 2.5G 25000 SL	S10291284162256	40	14	27	34	M10	120
BBT40 SFH14 160 FCC 2.5G 25000 SL	S10291284175256	40	14	27	34	M10	160
BBT40 SFH16 090 FCC 2.5G 25000 SL	S10291281140256	40	16	27	34	M12	90
BBT40 SFH16 120 FCC 2.5G 25000 SL	S10291281162256	40	16	27	34	M12	120
BBT40 SFH16 160 FCC 2.5G 25000 SL	S10291281175256	40	16	27	34	M12	160
BBT40 SFH18 090 FCC 2.5G 25000 SL	S10291282140256	40	18	33	40	M12	90
BBT40 SFH18 120 FCC 2.5G 25000 SL	S10291282162256	40	18	33	40	M12	120
BBT40 SFH18 160 FCC 2.5G 25000 SL	S10291282175256	40	18	33	40	M12	160
BBT40 SFH20 090 FCC 2.5G 25000 SL	S10291283140256	40	20	33	40	M16	90
BBT40 SFH20 120 FCC 2.5G 25000 SL	S10291283162256	40	20	33	40	M16	120
BBT40 SFH20 160 FCC 2.5G 25000 SL	S10291283175256	40	20	33	40	M16	160
BBT40 SFH25 100 FCC 2.5G 25000 SL	S10291287148256	40	25	44	53	M16	100
BBT40 SFH25 120 FCC 2.5G 25000 SL	S10291287162256	40	25	44	53	M16	120
BBT40 SFH25 160 FCC 2.5G 25000 SL	S10291287175256	40	25	44	53	M16	160
BBT40 SFH32 100 FCC 2.5G 25000 SL	S10291288148256	40	32	44	53	M16	100
BBT40 SFH32 120 FCC 2.5G 25000 SL	S10291288162256	40	32	44	53	M16	120
BBT40 SFH32 160 FCC 2.5G 25000 SL	S10291288175256	40	32	44	53	M16	160

Note: All Dimensions are in mm

**BBT (BT MAS 403)
Shrink Fit Holder (Face Coolant Channel)
(SFH 4.5°) (FCC)**

Maximum Run out of the Internal Dia with respect to the External Taper 0.003 mm

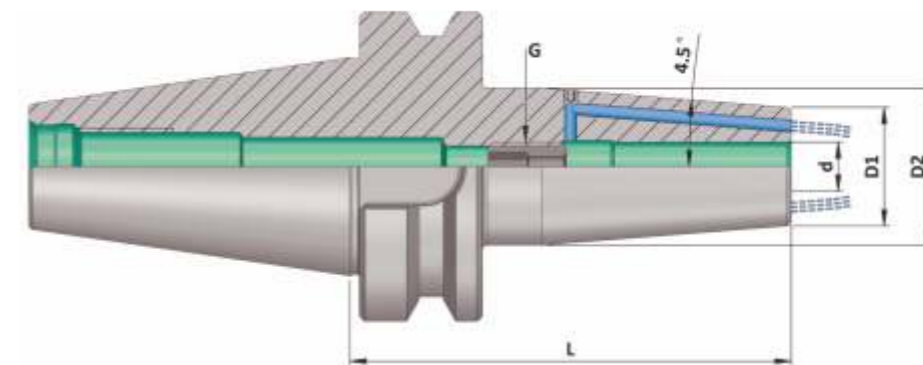

BBT (SFH 4.5°) (FCC)

(Balanced to 2.5 G 25000 RPM)

Item Name	Item Code	ISO	d	D1	D2	G	L
BBT50 SFH03 100 FCC 2.5G 25000 SL	S10308274148256	50	3	10	20	-	100
BBT50 SFH03 120 FCC 2.5G 25000 SL	S10308274162256	50	3	10	20	-	120
BBT50 SFH03 160 FCC 2.5G 25000 SL	S10308274175256	50	3	10	20	-	160
BBT50 SFH04 100 FCC 2.5G 25000 SL	S10308275148256	50	4	15	22	-	100
BBT50 SFH04 120 FCC 2.5G 25000 SL	S10308275162256	50	4	15	22	-	120
BBT50 SFH04 160 FCC 2.5G 25000 SL	S10308275175256	50	4	15	22	-	160
BBT50 SFH05 100 FCC 2.5G 25000 SL	S10308276148256	50	5	15	22	-	100
BBT50 SFH05 120 FCC 2.5G 25000 SL	S10308276162256	50	5	15	22	-	120
BBT50 SFH05 160 FCC 2.5G 25000 SL	S10308276175256	50	5	15	22	-	160
BBT50 SFH06 100 FCC 2.5G 25000 SL	S10308277148256	50	6	21	27	M5	100
BBT50 SFH06 120 FCC 2.5G 25000 SL	S10308277162256	50	6	21	27	M5	120
BBT50 SFH06 160 FCC 2.5G 25000 SL	S10308277175256	50	6	21	27	M5	160
BBT50 SFH08 100 FCC 2.5G 25000 SL	S10308285148256	50	8	21	27	M6	100
BBT50 SFH08 120 FCC 2.5G 25000 SL	S10308285162256	50	8	21	27	M6	120
BBT50 SFH08 160 FCC 2.5G 25000 SL	S10308285175256	50	8	21	27	M6	160
BBT50 SFH10 100 FCC 2.5G 25000SL	S10308279148207	50	10	24	31	M8	100
BBT50 SFH10 120 FCC 2.5G 25000 SL	S10308279162256	50	10	24	31	M8	120
BBT50 SFH10 160 FCC 2.5G 25000 SL	S10308279175256	50	10	24	31	M8	160
BBT50 SFH12 100 FCC 2.5G 25000 SL	S10308280148256	50	12	24	31	M10	100
BBT50 SFH12 120 FCC 2.5G 25000 SL	S10308280162256	50	12	24	31	M10	120
BBT50 SFH12 160 FCC 2.5G 25000 SL	S10308280175256	50	12	24	31	M10	160

Note: All Dimensions are in mm

**BBT (BT MAS 403)
Shrink Fit Holder (Face Coolant Channel)
(SFH 4.5°) (FCC)**

Maximum Run out of the Internal Dia with respect to the External Taper 0.003 mm

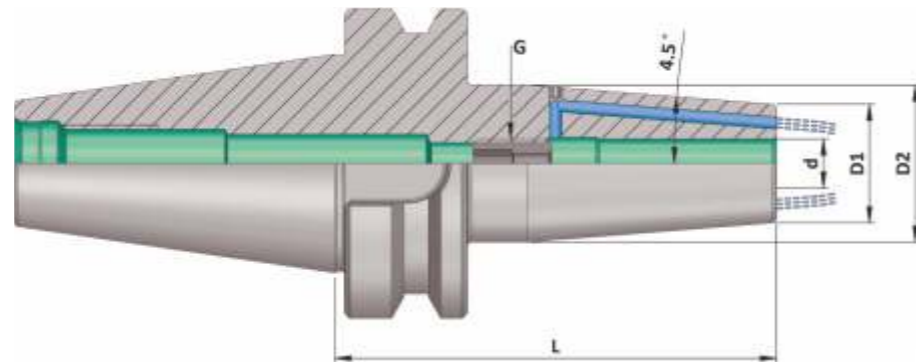

BBT (SFH 4.5°) (FCC)

(Balanced to 2.5 G 25000 RPM)

Item Name	Item Code	ISO	d	D1	D2	G	L
BBT50 SFH14 100 FCC 2.5G 25000 SL	S10308284148256	50	14	27	34	M10	100
BBT50 SFH14 120 FCC 2.5G 25000 SL	S10308284162256	50	14	27	34	M10	120
BBT50 SFH14 160 FCC 2.5G 25000 SL	S10308284175256	50	14	27	34	M10	160
BBT50 SFH16 100 FCC 2.5G 25000 SL	S10308281148256	50	16	27	34	M12	100
BBT50 SFH16 120 FCC 2.5G 25000 SL	S10308281162256	50	16	27	34	M12	120
BBT50 SFH16 160 FCC 2.5G 25000 SL	S10308281175256	50	16	27	34	M12	160
BBT50 SFH18 100 FCC 2.5G 25000 SL	S10308282148256	50	18	33	40	M12	100
BBT50 SFH18 120 FCC 2.5G 25000 SL	S10308282162256	50	18	33	40	M12	120
BBT50 SFH18 160 FCC 2.5G 25000 SL	S10308282175256	50	18	33	40	M12	160
BBT50 SFH20 100 FCC 2.5G 25000 SL	S10308283148256	50	20	33	40	M16	100
BBT50 SFH20 120 FCC 2.5G 25000 SL	S10308283162256	50	20	33	40	M16	120
BBT50 SFH20 160 FCC 2.5G 25000 SL	S10308283175256	50	20	33	40	M16	160
BBT50 SFH25 110 FCC 2.5G 25000 SL	S10308287156256	50	25	44	53	M16	110
BBT50 SFH25 120 FCC 2.5G 25000 SL	S10308287162256	50	25	44	53	M16	120
BBT50 SFH25 160 FCC 2.5G 25000 SL	S10308287175256	50	25	44	53	M16	160
BBT50 SFH32 110 FCC 2.5G 25000 SL	S10308288156256	50	32	44	53	M16	110
BBT50 SFH32 120 FCC 2.5G 25000 SL	S10308288162256	50	32	44	53	M16	120
BBT50 SFH32 160 FCC 2.5G 25000 SL	S10308288175256	50	32	44	53	M16	160

**BBT (BT MAS 403)
Shrink Fit Holder (SFH SLIM 3°) (AD)**

Maximum Run out of the Internal Dia with respect to the External Taper 0.003 mm

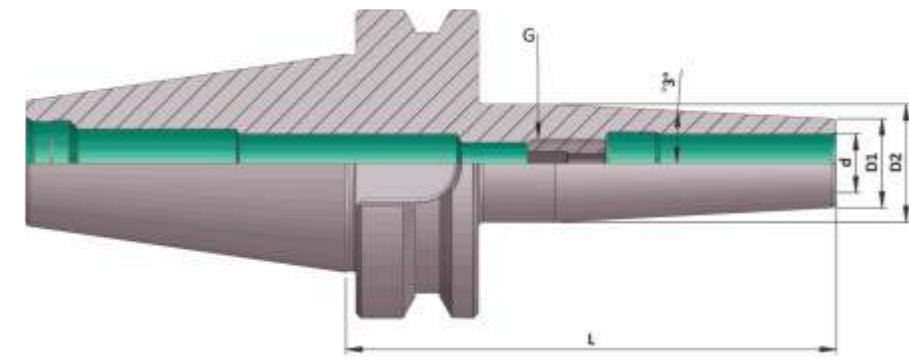

BBT (MAS 403) (SFH SLIM 3°) (AD)

(Balanced to 2.5 G 25000 RPM)

Item Name	Item Code	ISO	d	D1	D2	G	L
BBT30 SFH03 080 SLIM 2.5G 25000SL	S10307274131258	30	3	9	15	-	80
BBT30 SFH04 080 SLIM 2.5G 25000SL	S10307275131258	30	4	10	16	-	80
BBT30 SFH05 080 SLIM 2.5G 25000SL	S10307276131258	30	5	11	17	-	80
BBT30 SFH06 080 SLIM 2.5G 25000SL	S10307277131258	30	6	12	18	M5	80
BBT30 SFH08 080 SLIM 2.5G 25000SL	S10307285131258	30	8	14	20	M6	80
BBT30 SFH10 080 SLIM 2.5G 25000SL	S10307279131258	30	10	16	22	M8	80
BBT30 SFH12 080 SLIM 2.5G 25000SL	S10307280131258	30	12	18	24	M10	80
BBT30 SFH14 080 SLIM 2.5G 25000SL	S10307284131258	30	14	20	26	M10	80
BBT30 SFH16 080 SLIM 2.5G 25000SL	S10307281131258	30	16	22	28	M12	80
BBT30 SFH18 080 SLIM 2.5G 25000SL	S10307282131258	30	18	24	30	M12	80
BBT30 SFH20 080 SLIM 2.5G 25000SL	S10307283131258	30	20	26	32	M16	80

**BBT (BT MAS 403)
Shrink Fit Holder (SFH SLIM 3°) (AD)**

Maximum Run out of the Internal Dia with respect to the External Taper 0.003 mm

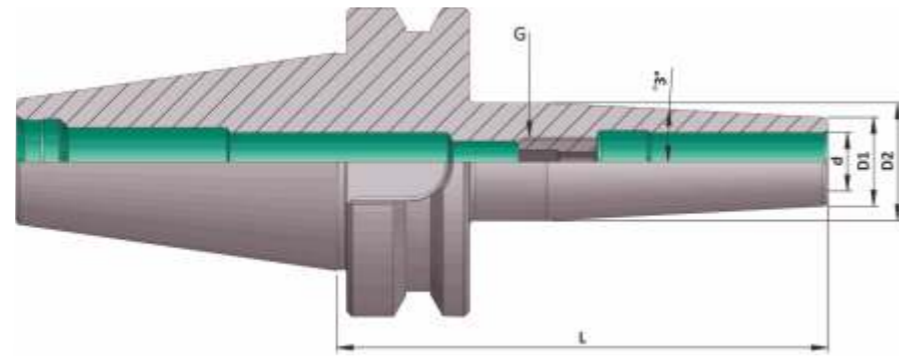

BBT (MAS 403) (SFH SLIM 3°) (AD)

(Balanced to 2.5 G 25000 RPM)

Item Name	Item Code	ISO	d	D1	D2	G	L
BBT40 SFH03 090 SLIM 2.5G 25000 SL	S10291274140258	40	3	9	15	-	90
BBT40 SFH03 120 SLIM 2.5G 25000 SL	S10291274162258	40	3	9	18	-	120
BBT40 SFH04 090 SLIM 2.5G 25000 SL	S10291275140258	40	4	10	16	-	90
BBT40 SFH04 120 SLIM 2.5G 25000 SL	S10291275162258	40	4	10	19	-	120
BBT40 SFH05 090 SLIM 2.5G 25000 SL	S10291276140258	40	5	11	17	-	90
BBT40 SFH05 120 SLIM 2.5G 25000 SL	S10291276162258	40	5	11	20	-	120
BBT40 SFH06 090 SLIM 2.5G 25000 SL	S10291277140258	40	6	12	18	M5	90
BBT40 SFH06 120 SLIM 2.5G 25000 SL	S10291277162258	40	6	12	21	M5	120
BBT40 SFH06 160 SLIM 2.5G 25000 SL	S10291277175258	40	6	12	25	M5	160
BBT40 SFH08 090 SLIM 2.5G 25000 SL	S10291285140258	40	8	14	20	M6	90
BBT40 SFH08 120 SLIM 2.5G 25000 SL	S10291285162258	40	8	14	23	M6	120
BBT40 SFH08 160 SLIM 2.5G 25000 SL	S10291285175258	40	8	14	27	M6	160
BBT40 SFH10 090 SLIM 2.5G 25000 SL	S10291279140258	40	10	16	22	M8	90
BBT40 SFH10 120 SLIM 2.5G 25000 SL	S10291279162258	40	10	16	25	M8	120
BBT40 SFH10 160 SLIM 2.5G 25000 SL	S10291279175258	40	10	16	29	M8	160
BBT40 SFH12 090 SLIM 2.5G 25000 SL	S10291280140258	40	12	18	24	M10	90
BBT40 SFH12 120 SLIM 2.5G 25000 SL	S10291280162258	40	12	18	27	M10	120
BBT40 SFH12 160 SLIM 2.5G 25000 SL	S10291280175258	40	12	18	31	M10	160
BBT40 SFH14 090 SLIM 2.5G 25000 SL	S10291284140258	40	14	20	26	M10	90
BBT40 SFH14 120 SLIM 2.5G 25000 SL	S10291284162258	40	14	20	29	M10	120
BBT40 SFH14 160 SLIM 2.5G 25000 SL	S10291284175258	40	14	20	32	M10	160
BBT40 SFH16 090 SLIM 2.5G 25000 SL	S10291281140258	40	16	22	28	M12	90
BBT40 SFH16 120 SLIM 2.5G 25000 SL	S10291281162258	40	16	22	31	M12	120
BBT40 SFH16 160 SLIM 2.5G 25000 SL	S10291281175258	40	16	22	34	M12	160
BBT40 SFH18 090 SLIM 2.5G 25000 SL	S10291282140258	40	18	24	30	M12	90
BBT40 SFH18 120 SLIM 2.5G 25000 SL	S10291282162258	40	18	24	33	M12	120
BBT40 SFH18 160 SLIM 2.5G 25000 SL	S10291282175258	40	18	24	36	M12	160
BBT40 SFH20 090 SLIM 2.5G 25000 SL	S10291283140258	40	20	26	32	M16	90
BBT40 SFH20 120 SLIM 2.5G 25000 SL	S10291283162258	40	20	26	35	M16	120
BBT40 SFH20 160 SLIM 2.5G 25000 SL	S10291283175258	40	20	26	38	M16	160

Note: All Dimensions are in mm

**BBT (BT MAS 403)
Shrink Fit Holder (SFH SLIM 3°) (AD)**

Maximum Run out of the Internal Dia with respect to the External Taper 0.003 mm

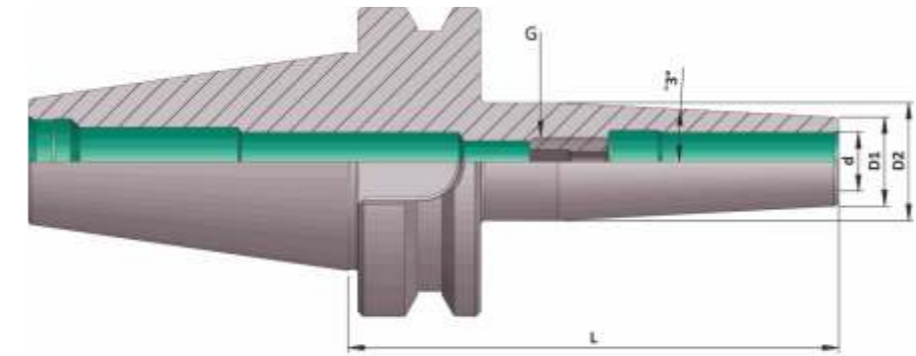

BBT (MAS 403) (SFH SLIM 3°) (AD)

(Balanced to 2.5 G 25000 RPM)

Item Name	Item Code	ISO	d	D1	D2	G	L
BBT50 SFH03 100 SLIM 2.5G 25000 SL	S10308274148258	50	3	9	15.5	-	100
BBT50 SFH03 120 SLIM 2.5G 25000 SL	S10308274162258	50	3	9	17.5	-	120
BBT50 SFH04 100 SLIM 2.5G 25000 SL	S10308275148258	50	4	10	16.5	-	100
BBT50 SFH04 120 SLIM 2.5G 25000 SL	S10308275162258	50	4	10	18.5	-	120
BBT50 SFH05 100 SLIM 2.5G 25000 SL	S10308276148258	50	5	11	17.5	-	100
BBT50 SFH05 120 SLIM 2.5G 25000 SL	S10308276162258	50	5	11	19.5	-	120
BBT50 SFH06 100 SLIM 2.5G 25000 SL	S10308277148258	50	6	12	18.5	M5	100
BBT50 SFH06 120 SLIM 2.5G 25000 SL	S10308277162258	50	6	12	20.5	M5	120
BBT50 SFH06 160 SLIM 2.5G 25000 SL	S10308277175258	50	6	12	25	M5	160
BBT50 SFH08 100 SLIM 2.5G 25000 SL	S10308285148258	50	8	14	20.5	M6	100
BBT50 SFH08 120 SLIM 2.5G 25000 SL	S10308285162258	50	8	14	22.5	M6	120
BBT50 SFH08 160 SLIM 2.5G 25000 SL	S10308285175258	50	8	14	27	M6	160
BBT50 SFH10 100 SLIM 2.5G 25000 SL	S10308279148258	50	10	16	22.5	M8	100
BBT50 SFH10 120 SLIM 2.5G 25000 SL	S10308279162258	50	10	16	24.5	M8	120
BBT50 SFH10 160 SLIM 2.5G 25000 SL	S10308279175258	50	10	16	29	M8	160
BBT50 SFH12 100 SLIM 2.5G 25000 SL	S10308280148258	50	12	18	24.5	M10	100
BBT50 SFH12 120 SLIM 2.5G 25000 SL	S10308280162258	50	12	18	26.5	M10	120
BBT50 SFH12 160 SLIM 2.5G 25000 SL	S10308280175258	50	12	18	31	M10	160
BBT50 SFH14 100 SLIM 2.5G 25000 SL	S10308284148258	50	14	20	26	M10	100
BBT50 SFH14 120 SLIM 2.5G 25000 SL	S10308284162258	50	14	20	29	M10	120
BBT50 SFH14 160 SLIM 2.5G 25000 SL	S10308284175258	50	14	20	32	M10	160
BBT50 SFH16 100 SLIM 2.5G 25000 SL	S10308281148258	50	16	22	28	M12	100
BBT50 SFH16 120 SLIM 2.5G 25000 SL	S10308281162258	50	16	22	31	M12	120
BBT50 SFH16 160 SLIM 2.5G 25000 SL	S10308281175258	50	16	22	34	M12	160
BBT50 SFH18 100 SLIM 2.5G 25000 SL	S10308282148258	50	18	24	30	M12	100
BBT50 SFH18 120 SLIM 2.5G 25000 SL	S10308282162258	50	18	24	33	M12	120
BBT50 SFH18 160 SLIM 2.5G 25000 SL	S10308282175258	50	18	24	36	M12	160
BBT50 SFH20 100 SLIM 2.5G 25000 SL	S10308283148258	50	20	26	32	M16	100
BBT50 SFH20 120 SLIM 2.5G 25000 SL	S10308283162258	50	20	26	35	M16	120
BBT50 SFH20 160 SLIM 2.5G 25000 SL	S10308283175258	50	20	26	38	M16	160

Note: All Dimensions are in mm

Minimum Length Compensation Tapping Chuck (MLC)

◆ Features :

- Sigma "Minimum Length Compensation Tapping Chuck (MLC)" For Synchronised (Rigid) Tapping Cycle.
- Best suitable for Die & Mould Industry.
- Compression & Expansion +/- 0.5mm
- High Concentricity Enables High Speed Tapping.
- Positive Clamping Through ER Tap Collet.

◆ Technical Details :

- "MLC" Tapping Chucks to be used with CNC Machines, having Synchronised Tapping cycle.
- In this case, Rigid Tapping cycle takes care of tap pitch controlling the feed, spindle speed and feed. So, theoretically, ordinary holder without any compensation also should be suitable for performing the process.
- ◆ But by law of theory, following factors they do affect tapping quality, tap life etc.
 1. Dynamics of machine
 2. Synchronisation of spindle speed & feed.
 3. During Change of Spindle, Rotational direction and feed direction.
 4. Pitch error on Tap / Tolerance on Pitch

◆ This will lead to :

1. Less Tap life because of Flank wear (one side)
2. Damaged Flanks on threads on the work piece
3. Threads not answering to Gauge.

◆ All above errors can be taken care by using ' MLC '

◆ Sigma 'MLC' Tapping Chucks with +/- 0.5 mm compensation.

◆ Available In Following Range :

- ER 16 : M3 to M12
- ER 20 : M3 to M16
- ER 25 : M3 to M20
- ER 32 : M4 to M27
- ER 40 : M6 to M33

◆ Available In Mountings :

- HSK- A (DIN 69893-1)
- BT (MAS 403) (DIN ISO 7388 - 2)
- BBT (MAS 403)
- SK (DIN 69871) (DIN ISO 7388 - 1)
- Cylindrical Shank

◆ Balancing :

- Main Body Balanced to 2.5G 25000 RPM



BBT (BT MAS 403) Minimum Length Compensation Tapping Chuck (MLC)

Maximum Run out of the Internal Taper with respect to the External Taper 0.020 mm

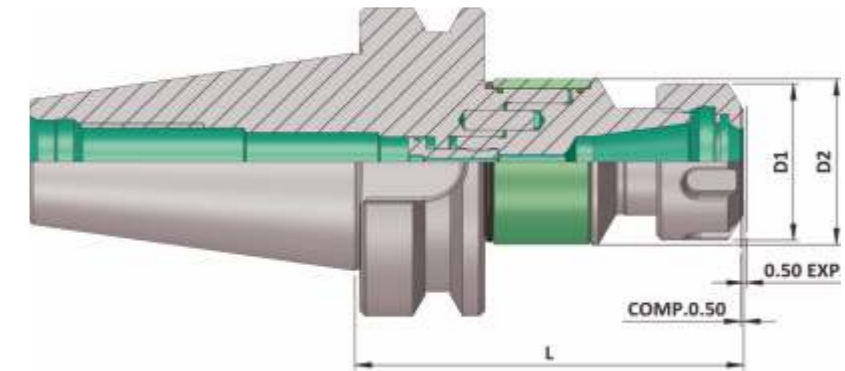

BBT (MLC)

Item Name	Item Code	ISO	Capacity	Clamping Range	Nut Size	D1	D2	L	Comp.	Exp.
BBT40 ER 16 079 AD MLC	S10291149551260	40	M3-M12	1-10	ER 16	32	34	79	0.50	0.50
BBT40 ER 20 085 AD MLC	S10291150135260	40	M3-M16	3.5-10	ER 20	35	34	85	0.50	0.50
BBT40 ER 25 089 AD MLC	S10291151139260	40	M3-M20	3.5-16	ER 25	42	34	89	0.50	0.50
BBT40 ER 32 110 AD MLC	S10291152156260	40	M4-M27	3.5-20	ER 32	50	45	110	0.50	0.50
BBT40 ER 40 115 AD MLC	S10291153159260	40	M6-M33	6-26	ER 40	63	62	115	0.50	0.50

BBT50 ER 16 095 AD MLC	S10308149145260	50	M3-M12	1-10	ER 16	32	34	95	0.50	0.50
BBT50 ER 20 100 AD MLC	S10308150148260	50	M3-M16	3.5-10	ER 20	35	34	100	0.50	0.50
BBT50 ER 25 110 AD MLC	S10308151156260	50	M3-M20	3.5-16	ER 25	42	34	110	0.50	0.50
BBT50 ER 32 120 AD MLC	S10308152162260	50	M4-M27	3.5-20	ER 32	50	45	120	0.50	0.50
BBT50 ER 40 120 AD MLC	S10308153162260	50	M6-M33	6-26	ER 40	63	62	120	0.50	0.50

Accessories:



Tap Collet ER G
Ref. Page No. 169-171



Q.C. Tap Collet QCTC
Ref. Page No. 174-182



ER Nut
Ref. Page No. 151-152



ER Spanner
Ref. Page No. 153

Note: All Dimensions are in mm



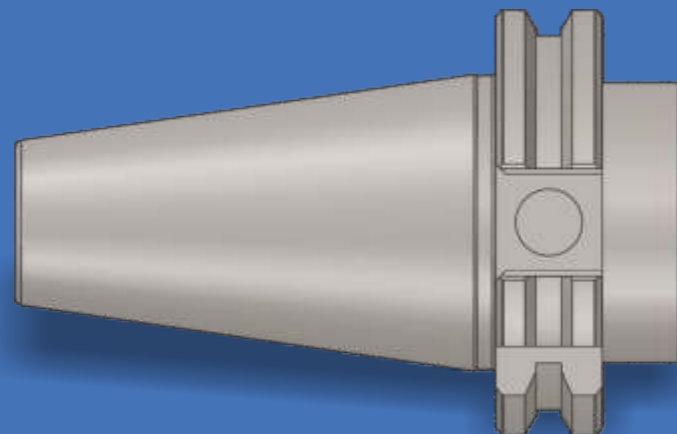



**Precision Tool Holders
SK - DIN ISO 7388 - 1
(DIN 69871)**



INDEX

Sr. No.	Contents		Page No.
1	Technical Information: SK - DIN ISO 7388 - 1 (DIN 69871)		101
2	Collet Chuck ER (DIN 6499) <ul style="list-style-type: none"> • Collet Chuck ER (AD) DIN ISO 7388 - 1 AD • Collet Chuck ER (AD+B) DIN ISO 7388 - 1 AD/AF • Collet Chuck ER "M" Type (AD+B) DIN ISO 7388 - 1 AD/AF • Collet Chuck ER "A" Type (Short GP) 		102 - 105
3	Weldon Type End Mill Holders (DIN 6359) <ul style="list-style-type: none"> • Weldon (WE) (AD) DIN ISO 7388 - 1 AD 		106 - 107
4	Face Mill Holders (DIN 6357) <ul style="list-style-type: none"> • FMH (AD) DIN ISO 7388 - 1 AD • FMH-K Through Coolant (AD+B) DIN ISO 7388 - 1 AD/AF 		108 - 109
5	Boring Bar Blank		110
6	Master Mandrell		111
7	NC Drill Chuck (NDCDC)		112

INDEX

Sr. No.	Contents		Page No.
8	Die & Mould Chuck (DMC)		113 - 114
9	Power Milling Chuck (PMC)		115 - 116
10	Milling Cutter Arbor (MCA)		117 - 119
11	Shrink Fit Holders 4.5 Degree (SFH 4.5°) <ul style="list-style-type: none"> Shrink Fit Holder (SFH 4.5°) (AD+B) DIN ISO 7388 - 1 AD/AF Shrink Fit Holder (SFH FCC 4.5°) (AD+B) DIN ISO 7388 - 1 AD/AF (Face Coolant Channel) 		120 - 127
12	Shrink Fit Holders Slim 3 Degree (SFH Slim 3°) <ul style="list-style-type: none"> Shrink Fit Holder (SFH Slim 3°) (AD+B) DIN ISO 7388 - 1 AD/AF 		128 - 129
13	Minimum Length Compensation Tapping Chuck (MLC)		130 - 131

SK (DIN 69871) (DIN ISO 7388- 1) :
Technical Information

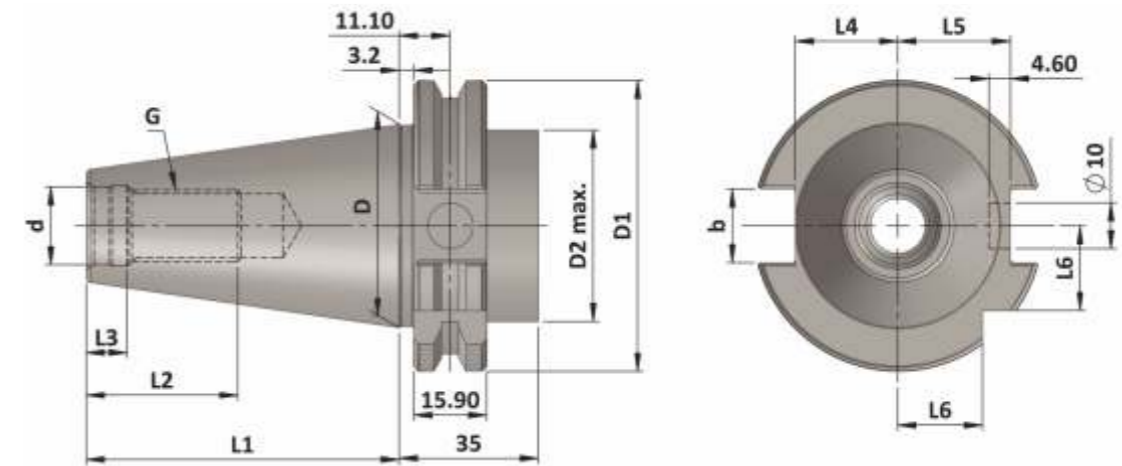

SK	d	d1	D	D1	D2	e	b	G	L1	L2	L3	L4	L5	L6
30	13	4	31.75	50.00	45	21	16.1	M12	47.80	24	5.5	16.4	19.0	15.00
40	17	4	44.45	63.55	50	27	16.1	M16	68.40	32	8.2	22.80	25.0	18.50
50	25	6	69.85	97.50	80	42	25.7	M24	101.75	47	11.5	35.5	37.7	30.00

Material :- Case hardened steel, tensile strength in the core min. 950 N/mm²

Execution :- Case hardened to HRC 58 ± 2, Case Depth 0.8 mm., Silver finish.

Accuracy :- 7:24 Taper Angle Class AT 3 As per DIN 2080

Old Name : SK (DIN 69871) AD
New Name : SK (DIN 69871) DIN ISO 7388- 1 AD
(Coolant Supply Through Center)

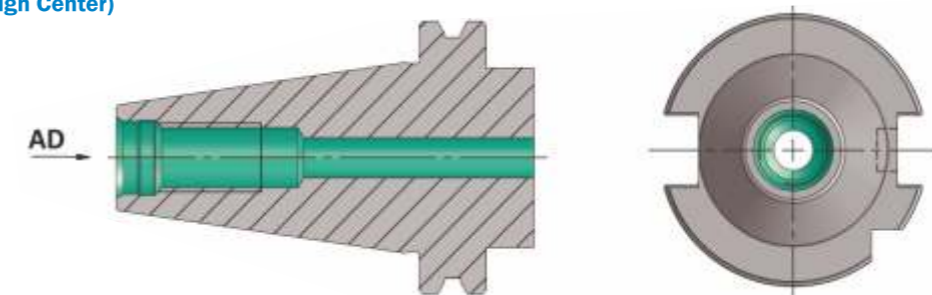

Old Name : SK (DIN 69871) AD+ B
New Name : SK (DIN 69871) DIN ISO 7388- 1 AD / AF
(Coolant Supply Through Flange)

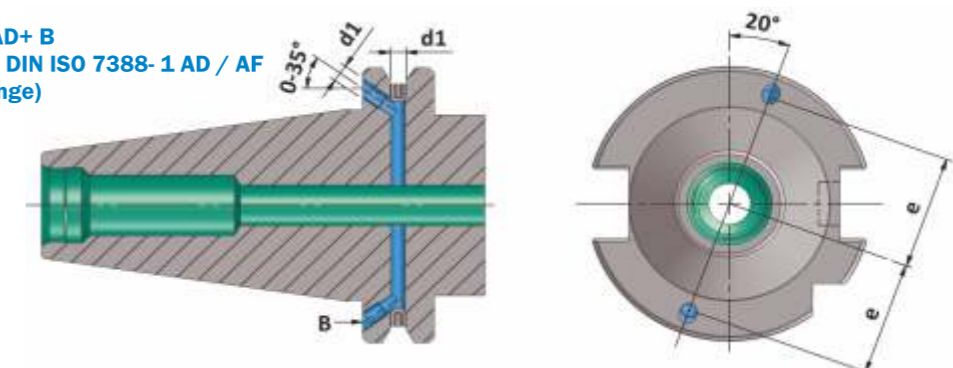

Note: All Dimensions are in mm

**SK (DIN 69871) (DIN ISO 7388- 1)
Collet Chuck ER (AD) (DIN 6499)**

Maximum Run out of the Internal Taper with respect to the External Taper 0.005 mm

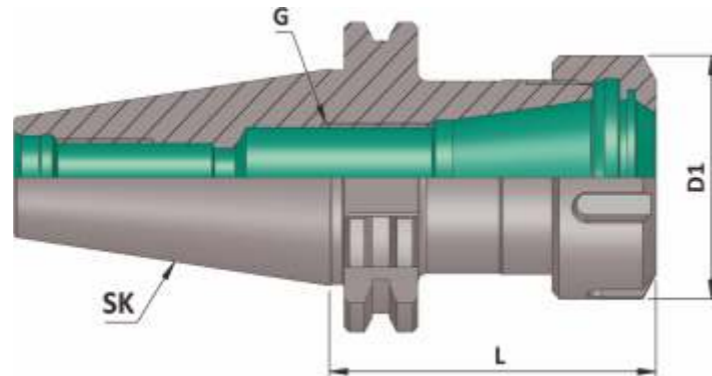

SK (DIN 69871) Collet Chuck ER (AD)

(Balanced to 6.3 G 15000 RPM)

Item Name	Item Code	SK	Suitable Collet	Collet Capacity	D1	G	L	Nut	Spanner
SK 40 ER 16 070 AD/6.3G15000 SL	S10104149125110	40	ER 16	0.5-10	32	M10X1	70	UM/ER16	E16
SK 40 ER 16 100 AD/6.3G15000 SL	S10104149148110	40	ER 16	0.5-10	32	M10X1	100	UM/ER16	E16
SK 40 ER 16 160 AD/6.3G15000 SL	S10104149175110	40	ER 16	0.5-10	32	M10X1	160	UM/ER16	E16
SK 40 ER 20 070 AD/6.3G15000 SL	S10104150125110	40	ER 20	1.0-13	35	M10X1	70	UM/ER20	E20
SK 40 ER 20 100 AD/6.3G15000 SL	S10104150148110	40	ER 20	1.0-13	35	M10X1	100	UM/ER20	E20
SK 40 ER 20 160 AD/6.3G15000 SL	S10104150175110	40	ER 20	1.0-13	35	M10X1	160	UM/ER20	E20
SK 40 ER 25 070 AD/6.3G15000 SL	S10104151125110	40	ER 25	1.0-16	42	M18X1	70	UM/ER25	E25
SK 40 ER 25 100 AD/6.3G15000 SL	S10104151148110	40	ER 25	1.0-16	42	M18X1	100	UM/ER25	E25
SK 40 ER 25 160 AD/6.3G15000 SL	S10104151175110	40	ER 25	1.0-16	42	M18X1	160	UM/ER25	E25
SK 40 ER 32 070 AD/6.3G15000 SL	S10104152125110	40	ER 32	2.0-20	50	M22X1.5	70	UM/ER32	E32
SK 40 ER 32 100 AD/6.3G15000 SL	S10104152148110	40	ER 32	2.0-20	50	M22X1.5	100	UM/ER32	E32
SK 40 ER 32 160 AD/6.3G15000 SL	S10104152175110	40	ER 32	2.0-20	50	M22X1.5	160	UM/ER32	E32
SK 40 ER 40 070 AD/6.3G15000 SL	S10104153125110	40	ER 40	3.0-26	63	M30X1.5	70	UM/ER40	E40
SK 40 ER 40 100 AD/6.3G15000 SL	S10104153148110	40	ER 40	3.0-26	63	M30X1.5	100	UM/ER40	E40
SK 40 ER 40 160 AD/6.3G15000 SL	S10104153175110	40	ER 40	3.0-26	63	M30X1.5	160	UM/ER40	E40
SK 40 ER 50 100 AD/6.3G15000 SL	S10104154148110	40	ER 50	10-34	78	M16X2	100	UM/ER50	E50

SK 50 ER 16 070 AD/6.3G15000 SL	S10105149125110	50	ER 16	0.5-10	32	M10X1	70	UM/ER16	E16
SK 50 ER 16 100 AD/6.3G15000 SL	S10105149148110	50	ER 16	0.5-10	32	M10X1	100	UM/ER16	E16
SK 50 ER 16 160 AD/6.3G15000 SL	S10105149175110	50	ER 16	0.5-10	32	M10X1	160	UM/ER16	E16
SK 50 ER 25 070 AD/6.3G15000 SL	S10105151125110	50	ER 25	1.0-16	42	M18X1	70	UM/ER25	E25
SK 50 ER 25 100 AD/6.3G15000 SL	S10105151148110	50	ER 25	1.0-16	42	M18X1	100	UM/ER25	E25
SK 50 ER 25 160 AD/6.3G15000 SL	S10105151175110	50	ER 25	1.0-16	42	M18X1	160	UM/ER25	E25
SK 50 ER 32 070 AD/6.3G15000 SL	S10105152125110	50	ER 32	2.0-20	50	M22X1.5	70	UM/ER32	E32
SK 50 ER 32 100 AD/6.3G15000 SL	S10105152148110	50	ER 32	2.0-20	50	M22X1.5	100	UM/ER32	E32
SK 50 ER 32 160 AD/6.3G15000 SL	S10105152175110	50	ER 32	2.0-20	50	M22X1.5	160	UM/ER32	E32
SK 50 ER 40 080 AD/6.3G15000 SL	S10105153131110	50	ER 40	3.0-26	63	M30X1.5	80	UM/ER40	E40
SK 50 ER 40 100 AD/6.3G15000 SL	S10105153148110	50	ER 40	3.0-26	63	M30X1.5	100	UM/ER40	E40
SK 50 ER 40 160 AD/6.3G15000 SL	S10105153175110	50	ER 40	3.0-26	63	M30X1.5	160	UM/ER40	E40
SK 50 ER 50 100 AD/6.3G15000 SL	S10105154148110	50	ER 50	10-34	78	M16X2	100	UM/ER50	E50
SK 50 ER 50 160 AD/6.3G15000 SL	S10105154175110	50	ER 50	10-34	78	M16X2	160	UM/ER50	E50

**SK (DIN 69871)(DIN ISO 7388- 1) AD/AF
Collet Chuck ER (AD+B) (DIN 6499)**

Maximum Run out of the Internal Taper with respect to the External Taper 0.005 mm

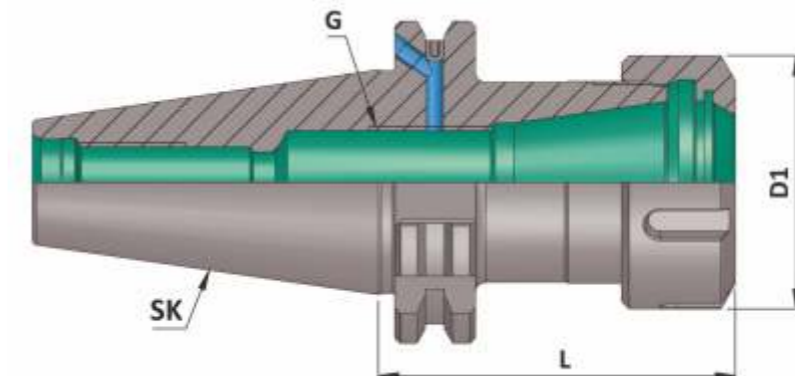

SK (DIN 69871) Collet Chuck ER (AD+B) AD/AF

(Balanced to 6.3 G 15000 RPM)

Item Name	Item Code	SK	Suitable Collet	Collet Capacity	D1	G	L	Nut	Spanner
SK 40 ER 16 070 AD+B/6.3G15000 SL	S10104149125112	40	ER 16	0.5-10	32	M10X1	70	UM/ER16	E16
SK 40 ER 16 100 AD+B/6.3G15000 SL	S10104149148112	40	ER 16	0.5-10	32	M10X1	100	UM/ER16	E16
SK 40 ER 16 160 AD+B/6.3G15000 SL	S10104149175112	40	ER 16	0.5-10	32	M10X1	160	UM/ER16	E16
SK 40 ER 20 070 AD+B/6.3G15000 SL	S10104150125112	40	ER 20	1.0-13	35	M10X1	70	UM/ER20	E20
SK 40 ER 20 100 AD+B/6.3G15000 SL	S10104150148112	40	ER 20	1.0-13	35	M10X1	100	UM/ER20	E20
SK 40 ER 20 160 AD+B/6.3G15000 SL	S10104150175112	40	ER 20	1.0-13	35	M10X1	160	UM/ER20	E20
SK 40 ER 25 070 AD+B/6.3G15000 SL	S10104151125112	40	ER 25	1.0-16	42	M18X1	70	UM/ER25	E25
SK 40 ER 25 100 AD+B/6.3G15000 SL	S10104151148112	40	ER 25	1.0-16	42	M18X1	100	UM/ER25	E25
SK 40 ER 25 160 AD+B/6.3G15000 SL	S10104151175112	40	ER 25	1.0-16	42	M18X1	160	UM/ER25	E25
SK 40 ER 32 070 AD+B/6.3G15000 SL	S10104152125112	40	ER 32	2.0-20	50	M22X1.5	70	UM/ER32	E32
SK 40 ER 32 100 AD+B/6.3G15000 SL	S10104152148112	40	ER 32	2.0-20	50	M22X1.5	100	UM/ER32	E32
SK 40 ER 32 160 AD+B/6.3G15000 SL	S10104152175112	50	ER 32	2.0-20	50	M22X1.5	160	UM/ER32	E32
SK 40 ER 40 070 AD+B/6.3G15000 SL	S10104153125112	40	ER 40	3.0-26	63	M30X1.5	70	UM/ER40	E40
SK 40 ER 40 100 AD+B/6.3G15000 SL	S10104153148112	40	ER 40	3.0-26	63	M30X1.5	100	UM/ER40	E40
SK 40 ER 40 160 AD+B/6.3G15000 SL	S10104153175112	40	ER 40	3.0-26	63	M30X1.5	160	UM/ER40	E40
SK 40 ER 50 100 AD+B/6.3G15000 SL	S10104154148112	40	ER 50	10-34	78	M16X2P	100	UM/ER50	E50

SK 50 ER 16 070 AD+B/6.3G15000 SL	S10105149125112	50	ER 16	0.5-10	32	M10X1	70	UM/ER16	E16
SK 50 ER 16 100 AD+B/6.3G15000 SL	S10105149148112	50	ER 16	0.5-10	32	M10X1	100	UM/ER16	E16
SK 50 ER 16 160 AD+B/6.3G15000 SL	S10105149175112	50	ER 16	0.5-10	32	M10X1	160	UM/ER16	E16
SK 50 ER 25 070 AD+B/6.3G15000 SL	S10105151125112	50	ER 25	1.0-16	42	M18X1	70	UM/ER25	E25
SK 50 ER 25 100 AD+B/6.3G15000 SL	S10105151148112	50	ER 25	1.0-16	42	M18X1	100	UM/ER25	E25
SK 50 ER 25 160 AD+B/6.3G15000 SL	S10105151175112	50	ER 25	1.0-16	42	M18X1	160	UM/ER25	E25
SK 50 ER 32 070 AD+B/6.3G15000 SL	S10105152125112	50	ER 32	2.0-20	50	M22X1.5	70	UM/ER32	E32
SK 50 ER 32 100 AD+B/6.3G15000 SL	S10105152148112	50	ER 32	2.0-20	50	M22X1.5	100	UM/ER32	E32
SK 50 ER 32 160 AD+B/6.3G15000 SL	S10105152175112	50	ER 32	2.0-20	50	M22X1.5	160	UM/ER32	E32
SK 50 ER 40 080 AD+B/6.3G15000 SL	S10105153131112	50	ER 40	3.0-26	63	M30X1.5	80	UM/ER40	E40
SK 50 ER 40 100 AD+B/6.3G15000 SL	S10105153148112	50	ER 40	3.0-26	63	M30X1.5	100	UM/ER40	E40
SK 50 ER 40 160 AD+B/6.3G15000 SL	S10105153175112	50	ER 40	3.0-26	63	M30X1.5	160	UM/ER40	E40
SK 50 ER 50 100 AD+B/6.3G15000 SL	S10105154148112	50	ER 50	10-34	78	M16X2	100	UM/ER50	E50
SK 50 ER 50 160 AD+B/6.3G15000 SL	S10105154175112	50	ER 50	10-34	78	M16X2	160	UM/ER50	E50

Note: All Dimensions are in mm
For Necessary Accessories Selection Please Go Through Page No. 104

**SK (DIN 69871) (DIN ISO 7388- 1) AD/AF
Collet Chuck ER-M Type (AD+B) (DIN 6499)**

Maximum Run out of the Internal Taper with respect to the External Taper 0.005 mm

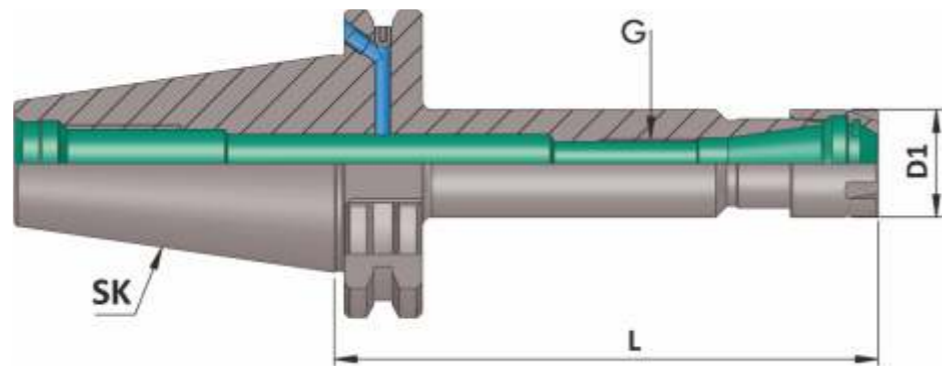

SK (DIN 69871) Collet Chuck ER M Type (AD+B) AD/AF

(Balanced to 2.5 G 25000 RPM)

Item Name	Item Code	SK	Suitable Collet	Collet Capacity	D1	G	L	Nut	Spanner
SK 40 ER11M 050 AD+B/2.5G 25000 SL	S10104156111230	40	ER 11	0.5-7	16	M6X1	50	ER11M	E11M
SK 40 ER11M 100 AD+B/2.5G 25000 SL	S10104156148230	40	ER 11	0.5-7	16	M6X1	100	ER11M	E11M
SK 40 ER11M 160 AD+B/2.5G 25000 SL	S10104156175230	40	ER 11	0.5-7	16	M6X1	160	ER11M	E11M
SK 40 ER16M 070 AD+B/2.5G 25000 SL	S10104157125230	40	ER 16	0.5-10	22	M10X1	70	ER16M	E16M
SK 40 ER16M 100 AD+B/2.5G 25000 SL	S10104157148140	40	ER 16	0.5-10	22	M10X1	100	ER16M	E16M
SK 40 ER16M 160 AD+B/2.5G 25000 SL	S10104157175230	40	ER 16	0.5-10	22	M10X1	160	ER16M	E16M
SK 40 ER25M 070 AD+B/2.5G 25000 SL	S10104159125230	40	ER 25	1.0-16	35	M18X1	70	ER25M	E25M
SK 40 ER25M 100 AD+B/2.5G 25000 SL	S10104159148230	40	ER 25	1.0-16	35	M18X1	100	ER25M	E25M
SK 40 ER25M 160 AD+B/2.5G 25000 SL	S10104159175230	40	ER 25	1.0-16	35	M18X1	160	ER25M	E25M

Accessories:

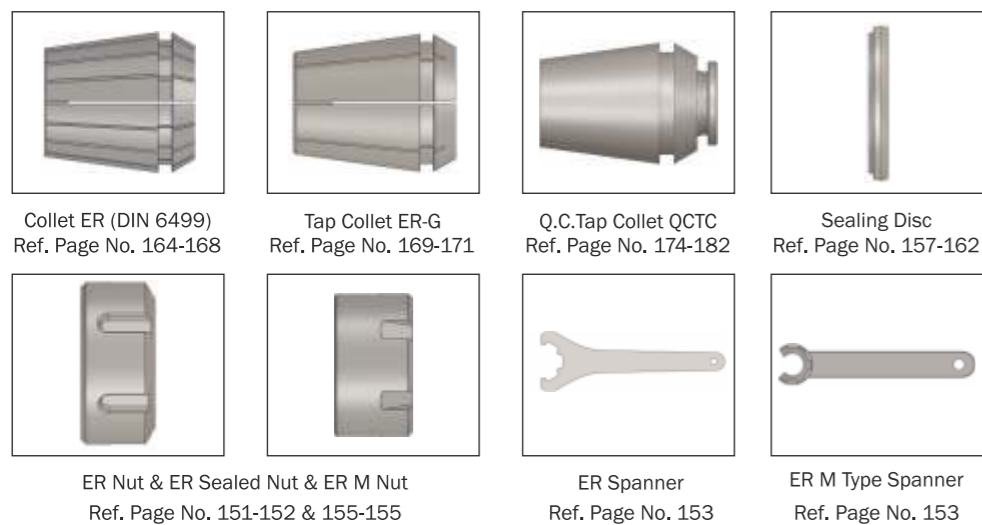

**SK (DIN 69871)(DIN ISO 7388- 1)
Short GP Collet Chuck ER -A**

Maximum Run out of the Internal Taper with respect to the External Taper 0.005 mm

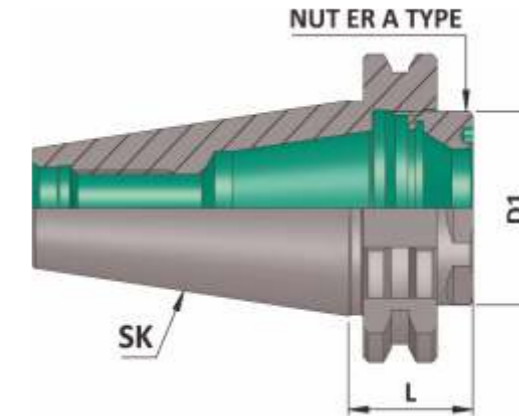

SK (DIN 69871) Short GP Collect Chuck ER-A

(Balanced to 6.3 G 15000 RPM)

Item Name	Item Code	SK	Suitable Collet	Collet Capacity	D1	L	NUT
SK 40 ER 32A 24 AD/6.3G15000 SL	S10104244248110	40	ER 32	2-20	40	24	ER32A
SK 50 ER 32A 24 AD/6.3G15000 SL	S10105244248110	50	ER 32	2-20	40	24	ER32A

Accessories:



**SK (DIN 69871) (DIN ISO 7388- 1)
Weldon Type End Mill Holder (WE) (AD) (DIN 6359)**

Maximum Run out of the Internal Dia with respect to the External Taper 0.005 mm

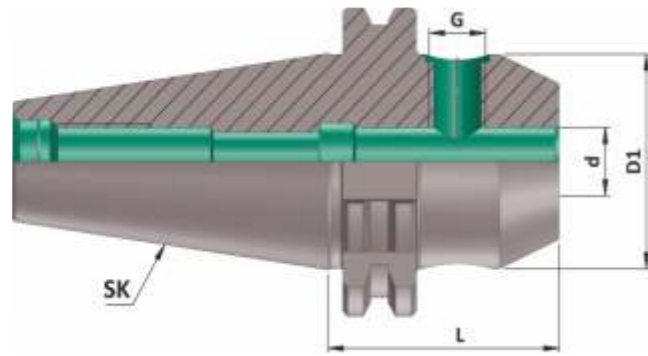

SK (DIN 69871) (WE) (AD)

(Balanced to 6.3 G 15000 RPM)

Item Name	Item Code	SK	d	D1	G	L	Screw Qty.
SK 40 WE06 050 AD/6.3G15000 SL	S10104111111110	40	6	25	M6	50	1
SK 40 WE06 100 AD/6.3G15000 SL	S10104111148110	40	6	25	M6	100	1
SK 40 WE06 160 AD/6.3G15000 SL	S10104111175110	40	6	25	M6	160	1
SK 40 WE08 050 AD/6.3G15000 SL	S10104112111110	40	8	28	M8	50	1
SK 40 WE08 100 AD/6.3G15000 SL	S10104112148110	40	8	28	M8	100	1
SK 40 WE08 160 AD/6.3G15000 SL	S10104112175110	40	8	28	M8	160	1
SK 40 WE10 050 AD/6.3G15000 SL	S10104113111110	40	10	35	M10	50	1
SK 40 W 10 100 AD/6.3G15000 SL	S10104113148110	40	10	35	M10	100	1
SK 40 WE10 160 AD/6.3G15000 SL	S10104113175110	40	10	35	M10	160	1
SK 40 WE12 050 AD/6.3G15000 SL	S10104114111110	40	12	42	M12	50	1
SK 40 WE12 100 AD/6.3G15000 SL	S10104114148110	40	12	42	M12	100	1
SK 40 WE12 160 AD/6.3G15000 SL	S10104114175110	40	12	42	M12	160	1
SK 40 WE14 050 AD/6.3G15000 SL	S10104258111110	40	14	44	M12	50	1
SK 40 WE14 100 AD/6.3G15000 SL	S10104258148110	40	14	44	M12	100	1
SK 40 WE14 160 AD/6.3G15000 SL	S10104258175110	40	14	44	M12	160	1
SK 40 WE16 063 AD/6.3G15000 SL	S10104115119110	40	16	48	M14	63	1
SK 40 WE16 100 AD/6.3G15000 SL	S10104115148110	40	16	48	M14	100	1
SK 40 WE16 160 AD/6.3G15000 SL	S10104115175110	40	16	48	M14	160	1
SK 40 WE18 063 AD/6.3G15000 SL	S10104259119110	40	18	50	M14	63	1
SK 40 WE18 100 AD/6.3G15000 SL	S10104259148110	40	18	50	M14	100	1
SK 40 WE18 160 AD/6.3G15000 SL	S10104259175110	40	18	50	M14	160	1
SK 40 WE20 063 AD/6.3G15000 SL	S10104116119110	40	20	52	M16	63	1
SK 40 WE20 100 AD/6.3G15000 SL	S10104116148110	40	20	52	M16	100	1
SK 40 WE20 160 AD/6.3G15000 SL	S10104116175110	40	20	52	M16	160	1
SK 40 WE25 100 AD/6.3G15000 SL	S10104117148110	40	25	65	M18X2	100	2
SK 40 WE25 160 AD/6.3G15000 SL	S10104117175110	40	25	65	M18X2	160	2
SK 40 WE32 100 AD/6.3G15000 SL	S10104118148110	40	32	72	M20X2	100	2
SK 40 WE32 160 AD/6.3G15000 SL	S10104118175110	40	32	72	M20X2	160	2
SK 40 WE40 115 AD/6.3G15000 SL	S10104119159110	40	40	80	M20X2	115	2
SK 40 WE40 160 AD/6.3G15000 SL	S10104119175110	40	40	80	M20X2	160	2

Note: All Dimensions are in mm
These Holders are most suitable for Weldon Type End Mill as per standard DIN 1835 - B

**SK (DIN 69871) (DIN ISO 7388- 1)
Weldon Type End Mill Holder (WE) (AD) (DIN 6359)**

Maximum Run out of the Internal Dia with respect to the External Taper 0.005 mm

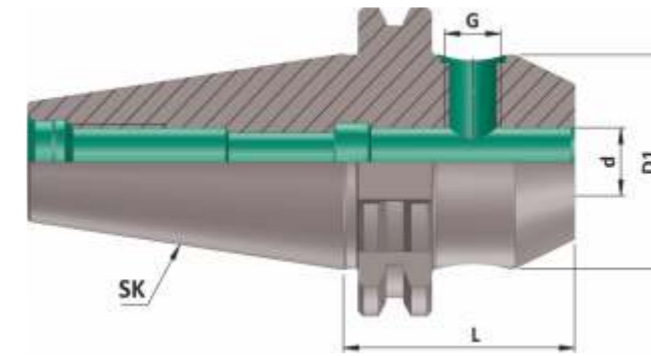

SK (DIN 69871) (WE) (AD)

(Balanced to 6.3 G 15000 RPM)

Item Name	Item Code	SK	d	D1	G	L	Screw Qty.
SK 50 WE 06 063 AD/6.3G15000 SL	S10105111119110	50	6	25	M6	63	1
SK 50 WE 06 100 AD/6.3G15000 SL	S10105111148110	50	6	25	M6	100	1
SK 50 WE 06 160 AD/6.3G15000 SL	S10105111175110	50	6	25	M6	160	1
SK 50 WE 08 063 AD/6.3G15000 SL	S10105112119110	50	8	28	M8	63	1
SK 50 WE 08 100 AD/6.3G15000 SL	S10105112148110	50	8	28	M8	100	1
SK 50 WE 08 160 AD/6.3G15000 SL	S10105112175110	50	8	28	M8	160	1
SK 50 WE 10 063 AD/6.3G15000 SL	S10105113119110	50	10	35	M10	63	1
SK 50 WE 10 100 AD/6.3G15000 SL	S10105113148110	50	10	35	M10	100	1
SK 50 WE 10 160 AD/6.3G15000 SL	S10105113175110	50	10	35	M10	160	1
SK 50 WE 12 063 AD/6.3G15000 SL	S10105114119110	50	12	42	M12	63	1
SK 50 WE 12 100 AD/6.3G15000 SL	S10105114148110	50	12	42	M12	100	1
SK 50 WE 12 160 AD/6.3G15000 SL	S10105114175110	50	12	42	M12	160	1
SK 50 WE 14 063 AD/6.3G15000 SL	S10105258119110	50	14	44	M12	63	1
SK 50 WE 14 100 AD/6.3G15000 SL	S10105258148110	50	14	44	M12	100	1
SK 50 WE 14 160 AD/6.3G15000 SL	S10105258175110	50	14	44	M12	160	1
SK 50 WE 16 063 AD/6.3G15000 SL	S10105115119110	50	16	48	M14	63	1
SK 50 WE 16 100 AD/6.3G15000 SL	S10105115148110	50	16	48	M14	100	1
SK 50 WE 16 160 AD/6.3G15000 SL	S10105115175110	50	16	48	M14	160	1
SK 50 WE 18 063 AD/6.3G15000 SL	S10105259119110	50	18	50	M14	63	1
SK 50 WE 18 100 AD/6.3G15000 SL	S10105259148110	50	18	50	M14	100	1
SK 50 WE 18 160 AD/6.3G15000 SL	S10105259175110	50	18	50	M14	160	1
SK 50 WE 20 063 AD/6.3G15000 SL	S10105116119110	50	20	52	M16	63	1
SK 50 WE 20 100 AD/6.3G15000 SL	S10105116148110	50	20	52	M16	100	1
SK 50 WE 20 160 AD/6.3G15000 SL	S10105116175110	50	20	52	M16	160	1
SK 50 WE 25 080 AD/6.3G15000 SL	S10105117131110	50	25	65	M18X2	80	2
SK 50 WE 25 100 AD/6.3G15000 SL	S10105117148110	50	25	65	M18X2	100	2
SK 50 WE 25 160 AD/6.3G15000 SL	S10105117175110	50	25	65	M18X2	160	2
SK 50 WE 32 100 AD/6.3G15000 SL	S10105118148110	50	32	72	M20X2	100	2
SK 50 WE 32 160 AD/6.3G15000 SL	S10105118175110	50	32	72	M20X2	160	2
SK 50 WE 40 120 AD/6.3G15000 SL	S10105119162110	50	40	80	M20X2	120	2
SK 50 WE 40 160 AD/6.3G15000 SL	S10105119175110	50	40	80	M20X2	160	2
SK 50 WE 50 120 AD/6.3G15000 SL	S10105120162110	50	50	100	M24X2	120	2

Note: All Dimensions are in mm
These Holders are most suitable for Weldon Type End Mill as per standard DIN 1835 - B

**SK (DIN 69871) (DIN ISO 7388- 1)
Face Mill Holder (DIN 6357) (FMH) (AD)**

Maximum Run out of the External Dia with respect to the External Taper 0.005 mm

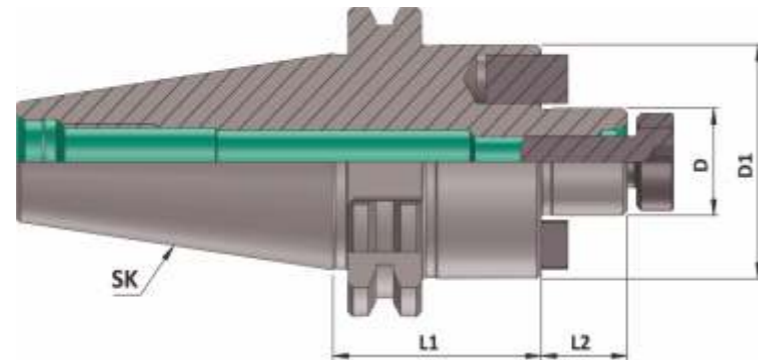

SK (DIN 69871) (FMH) (AD)

(Balanced to 6.3 G 15000 RPM)

Item Name	Item Code	SK	D	D1	L1	L2
SK 40 FMH16 045 AD/6.3G15000 SL SP.S	S10104126108232	40	16	38	45	17
SK 40 FMH16 100 AD/6.3G15000 SL SP.S	S10104126148232	40	16	38	100	17
SK 40 FMH16 160 AD/6.3G15000 SL SP.S	S10104126175232	40	16	38	160	17
SK 40 FMH22 045 AD/6.3G15000 SL SP.S	S10104127108232	40	22	48	45	19
SK 40 FMH22 100 AD/6.3G15000 SL SP.S	S10104127148232	40	22	48	100	19
SK 40 FMH22 160 AD/6.3G15000 SL SP.S	S10104127175232	40	22	48	160	19
SK 40 FMH27 050 AD/6.3G15000 SL SP.S	S10104128111232	40	27	58	50	21
SK 40 FMH27 100 AD/6.3G15000 SL SP.S	S10104128148232	40	27	58	100	21
SK 40 FMH27 160 AD/6.3G15000 SL SP.S	S10104128175232	40	27	58	160	21
SK 40 FMH32 055 AD/6.3G15000 SL SP.S	S10104129115232	40	32	78	55	24
SK 40 FMH32 100 AD/6.3G15000 SL SP.S	S10104129148232	40	32	78	100	24
SK 40 FMH32 160 AD/6.3G15000 SL SP.S	S10104129175232	40	32	78	160	24
SK 40 FMH40 055 AD/6.3G15000 SL SP.S	S10104130115232	40	40	88	55	27
SK 40 FMH40 100 AD/6.3G15000 SL SP.S	S10104130148232	40	40	88	100	27
SK 40 FMH40 160 AD/6.3G15000 SL SP.S	S10104130175232	40	40	88	160	27

SK 50 FMH16 045 AD/6.3G15000 SL SP.S	S10105126108232	50	16	38	45	17
SK 50 FMH16 100 AD/6.3G15000 SL SP.S	S10105126148232	50	16	38	100	17
SK 50 FMH16 160 AD/6.3G15000 SL SP.S	S10105126175232	50	16	38	160	17
SK 50 FMH22 045 AD/6.3G15000 SL SP.S	S10105127108232	50	22	48	45	19
SK 50 FMH22 100 AD/6.3G15000 SL SP.S	S10105127148232	50	22	48	100	19
SK 50 FMH22 160 AD/6.3G15000 SL SP.S	S10105127175232	50	22	48	160	19
SK 50 FMH27 045 AD/6.3G15000 SL SP.S	S10105128108232	50	27	58	45	21
SK 50 FMH27 100 AD/6.3G15000 SL SP.S	S10105128148232	50	27	58	100	21
SK 50 FMH27 160 AD/6.3G15000 SL SP.S	S10105128175232	50	27	58	160	21
SK 50 FMH32 050 AD/6.3G15000 SL SP.S	S10105129111232	50	32	78	50	24
SK 50 FMH32 100 AD/6.3G15000 SL SP.S	S10105129148232	50	32	78	100	24
SK 50 FMH32 160 AD/6.3G15000 SL SP.S	S10105129175232	50	32	78	160	24
SK 50 FMH40 055 AD/6.3G15000 SL SP.S	S10105267115232	50	40	88	55	27
SK 50 FMH40 100 AD/6.3G15000 SL SP.S	S10105267148232	50	40	88	100	27
SK 50 FMH40 160 AD/6.3G15000 SL SP.S	S10105267175232	50	40	88	160	27

Note: All Dimensions are in mm

**SK (DIN 69871) (DIN ISO 7388- 1)
Face Mill Holder (Through Coolant) (DIN 6357) (FMH-K)**

Maximum Run out of the External Dia with respect to the External Taper 0.005 mm

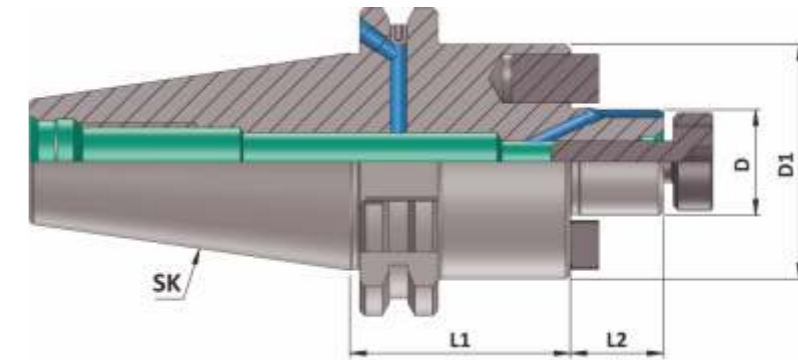

SK (DIN 69871) (FMH-K) (AD+B) AD/AF

(Balanced to 6.3 G 15000 RPM)

Item Name	Item Code	SK	D	D1	L1	L2
SK 40 FMH-K16 045 AD+B/6.3G15000 SL SP.S	S10104131108234	40	16	38	45	17
SK 40 FMH-K16 100 AD+B/6.3G15000 SL SP.S	S10104131148234	40	16	38	100	17
SK 40 FMH-K16 160 AD+B/6.3G15000 SL SP.S	S10104131175234	40	16	38	160	17
SK 40 FMH-K22 045 AD+B/6.3G15000 SL SP.S	S10104132108234	40	22	48	45	19
SK 40 FMH-K22 100 AD+B/6.3G15000 SL SP.S	S10104132148234	40	22	48	100	19
SK 40 FMH-K22 160 AD+B/6.3G15000 SL SP.S	S10104132175234	40	22	48	160	19
SK 40 FMH-K27 050 AD+B/6.3G15000 SL SP.S	S10104133111234	40	27	58	50	21
SK 40 FMH-K27 100 AD+B/6.3G15000 SL SP.S	S10104133148234	40	27	58	100	21
SK 40 FMH-K27 160 AD+B/6.3G15000 SL SP.S	S10104133175234	40	27	58	160	21
SK 40 FMH-K32 055 AD+B/6.3G15000 SL SP.S	S10104134115234	40	32	78	55	24
SK 40 FMH-K32 100 AD+B/6.3G15000 SL SP.S	S10104134148234	40	32	78	100	24
SK 40 FMH-K32 160 AD+B/6.3G15000 SL SP.S	S10104134175234	40	32	78	160	24
SK 40 FMH-K40 055 AD+B/6.3G15000 SL SP.S	S10104135115234	40	40	88	55	27
SK 40 FMH-K40 100 AD+B/6.3G15000 SL SP.S	S10104135148234	40	40	88	100	27
SK 40 FMH-K40 160 AD+B/6.3G15000 SL SP.S	S10104135175234	40	40	88	160	27

SK 50 FMH-K16 045 AD+B/6.3G15000 SL SP.S	S10105131108234	50	16	38	45	17
SK 50 FMH-K16 100 AD+B/6.3G15000 SL SP.S	S10105131148234	50	16	38	100	17
SK 50 FMH-K16 160 AD+B/6.3G15000 SL SP.S	S10105131175234	50	16	38	160	17
SK 50 FMH-K22 045 AD+B/6.3G15000 SL SP.S	S10105132108234	50	22	48	45	19
SK 50 FMH-K22 100 AD+B/6.3G15000 SL SP.S	S10105132148234	50	22	48	100	19
SK 50 FMH-K22 160 AD+B/6.3G15000 SL SP.S	S10105132175234	50	22	48	160	19
SK 50 FMH-K27 045 AD+B/6.3G15000 SL SP.S	S10105133108234	50	27	58	45	21
SK 50 FMH-K27 100 AD+B/6.3G15000 SL SP.S	S10105133148234	50	27	58	100	21
SK 50 FMH-K27 160 AD+B/6.3G15000 SL SP.S	S10105133175234	50	27	58	160	21
SK 50 FMH-K32 050 AD+B/6.3G15000 SL SP.S	S10105134111234	50	32	78	50	24
SK 50 FMH-K32 100 AD+B/6.3G15000 SL SP.S	S10105134148234	50	32	78	100	24
SK 50 FMH-K32 160 AD+B/6.3G15000 SL SP.S	S10105134175234	50	32	78	160	24
SK 50 FMH-K40 055 AD+B/6.3G15000 SL SP.S	S10105135115234	50	40	88	55	27
SK 50 FMH-K40 100 AD+B/6.3G15000 SL SP.S	S10105135148234	50	40	88	100	27
SK 50 FMH-K40 160 AD+B/6.3G15000 SL SP.S	S10105576175234	50	40	88	160	27

Note: All Dimensions are in mm

**SK (DIN 69871) (DIN ISO 7388- 1)
Boring Bar Blank**

**SK (DIN 69871) (DIN ISO 7388- 1)
Master Mandrell**

Maximum Run out of the External Dia with respect to the External Taper 0.003 mm

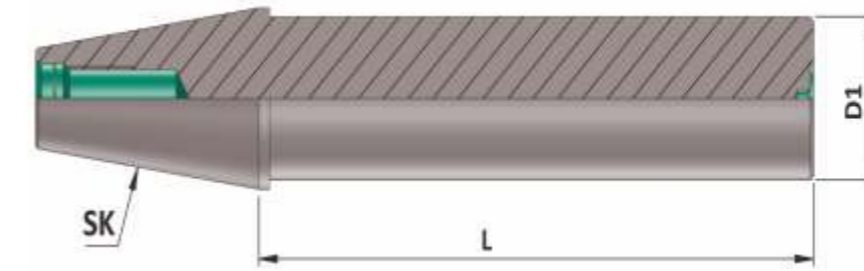
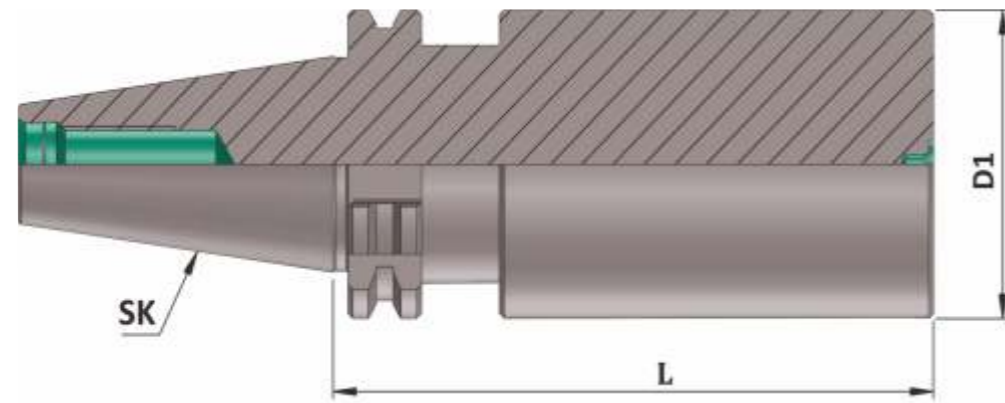

SK (DIN 69871) Boring Bar Blank

Item Name	Item Code	SK	D1	L
SK 40 BORING BAR BLANK DIA 63.5 L 160	S10104173330127	40	63.5	160
SK 40 BORING BAR BLANK DIA 63.5 L 250	S10104173256127	40	63.5	250
SK 50 BORING BAR BLANK DIA 80.0 L 160	S10105264330127	50	80	160
SK 50 BORING BAR BLANK DIA 80.0 L 200	S10105264237127	50	80	200
SK 50 BORING BAR BLANK DIA 80.0 L 250	S10105264256127	50	80	250
SK 50 BORING BAR BLANK DIA 80.0 L 300	S10105264257127	50	80	300
SK 50 BORING BAR BLANK DIA 97.0 L 315	S10105265329127	50	97	315

SK (DIN 69871) Master Mandrell

(Sub Zero Treated)

Item Name	Item Code	SK	D1	L
SK 40 MASTER MANDREL DIA40 L 300	S10104165257127	40	40	300
SK 50 MASTER MANDREL DIA50 L 350	S10105166258127	50	50	350

**SK (DIN 69871) (DIN ISO 7388- 1)
NC Drill Chuck (NCDC)**

Maximum Run out on the Mandrell with respect to the External Taper 0.050 mm

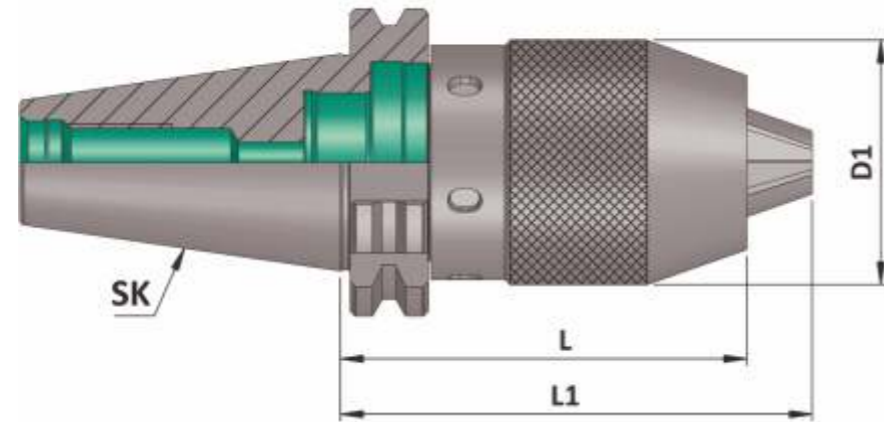

SK (DIN 69871) (NCDC)

Item Name	Item Code	SK	D1	L	L1
SK 40 NCDC 1-13 86	S10104167157110	40	50	86	98.5
SK 50 NCDC 1-13 108	S10105167151110	50	50	108	120.5

Accessories:

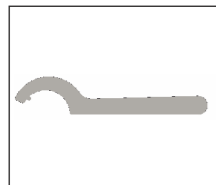

NCDC Spanner
Ref. Page No. 154

Die & Mould Chuck (DMC)

◆ **Features :**

- Small outside diameter.
- Best suitable for Die & Mould Industry.
- Most suitable for machining of cavities difficult to reach.
- High precision Runout < 0.005mm (4xd).
- All 'Sigma' Die & Mould Chucks are subjected to Sub-zero treatment (-90° C). This treatment helps to prevent the holders from deformation for many years & hence increases the life.

◆ **Capacity :**

- DMC 06 (3mm to 6mm)
- DMC 08 (3mm to 8 mm)
- DMC 10 (3mm to 10mm)

◆ **Available In Mountings :**

- HSK-A (DIN 69893-1)
- BT (MAS 403) (DIN ISO 7388-2)
- BBT (MAS 403)
- SK (DIN 69871) (DIN ISO 7388-1)
- Cylindrical Shank

◆ **Balancing :**

- Balanced To 2.5 G 25000 RPM



**SK (DIN 69871) (DIN ISO 7388- 1)
Die & Mould Chuck (DMC)**

Maximum Run out of the Internal Taper with respect to the External Taper < 0.005 mm

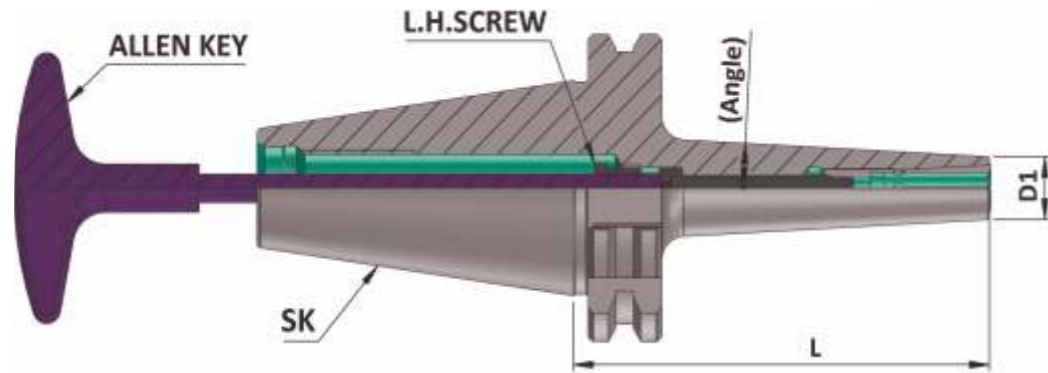

SK (DIN 69871)
DIN ISO 7388 - 1 Holders

SK (DIN 69871) (DMC)

(Balanced to 2.5 G 25000 RPM)

Item Name	Item Code	SK	Gripping Range	D1	L	Angle	Suitable Collet	Locking Screw	Allen Key
SK 40 DMC 06 060 AD/2.5G 25000 SL	S10104161117129	40	3-6	13	60	3	DMC-6	M5	4X200
SK 40 DMC 06 090 AD/2.5G 25000 SL	S10104161140129	40	3-6	13	90	3	DMC-6	M5	4X200
SK 40 DMC 06 120 AD/2.5G 25000 SL	S10104161162129	40	3-6	13	120	3	DMC-6	M5	4X200
SK 40 DMC 06 160 AD/ 2.5G 25000 SL	S10104161175124	40	3-6	13	160	3	DMC-6	M5	4X200
SK 40 DMC 08 090 AD/2.5G 25000 SL	S10104162140129	40	3-8	22	90	3	DMC-8	M6	5X200
SK 40 DMC 08 120 AD/2.5G 25000 SL	S10104162162129	40	3-8	22	120	3	DMC-8	M6	5X200
SK 40 DMC 08 160 AD/2.5G 25000 SL	S10104162175124	40	3-8	22	160	3	DMC-8	M6	5X200
SK 40 DMC 10 090 AD/2.5G 25000 SL	S10104163140129	40	3-10	28	90	3	DMC-10	M8	6X200
SK 40 DMC 10 120 AD/2.5G 25000 SL	S10104163162129	40	3-10	28	120	3	DMC-10	M8	6X200
SK 50 DMC 10 150 AD/2.5G 25000 SL	S10105163173129	50	3-10	28	150	3	DMC-10	M8	6X200

Accessories:



DMC Collet
Ref. Page No. 172

Power Milling Chuck (PMC)

◆ Features :

- ' Sigma ' Power Milling Chuck is Very Rigid & Precision.
- It is best for Drilling, Reaming & Milling Operations.
- The tool runs true less than 5 micron on 2D. Hence the tool life increases drastically.
- It's Unibody construction reduces the vibrations, This also helps to increase the tool life.
- All ' Sigma ' Die & Mould Chucks are subjected to Sub-zero treatment (-90° C). This treatment helps to prevent the holders from deformation for many years & hence increases the life.

◆ Available In Mountings :

- BT (MAS 403) (DIN ISO 7388 - 2)
- BBT (MAS 403)
- SK (DIN 69871) (DIN ISO 7388 - 1)
- HSK- A (DIN 69893-1)

◆ Balancing :

- Balanced To 6.3 G 15000 RPM



**SK (DIN 69871) (DIN ISO 7388- 1)
Power Milling Chuck (PMC)**

Maximum Run out of the Internal Dia with respect to the External Taper 0.005 mm

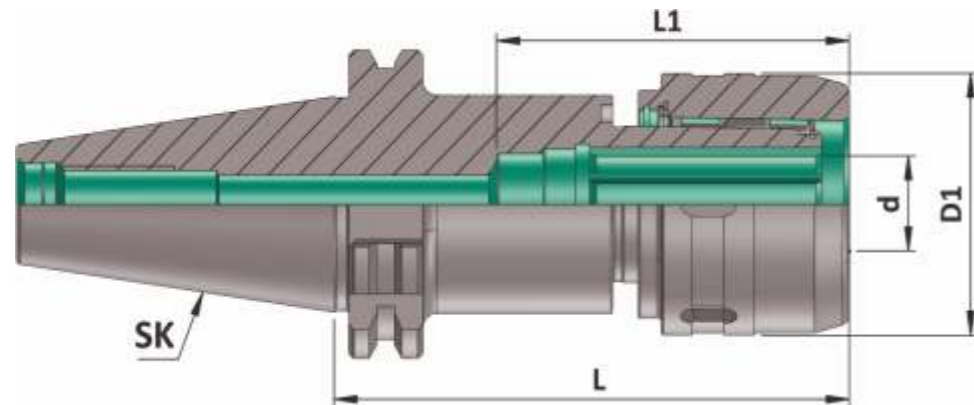

SK (DIN 69871)
DIN ISO 7388 - 1 Holders

SK (DIN 69871) (PMC)

(Balanced to 6.3 G 15000 RPM)

Item Name	Item Code	SK	d	D1	L	L1
SK 40 C 20105 AD/6.3 G15000 SL	S10104453355129	40	20	54	105	70
SK 40 C 32105 AD/6.3 G15000 SL	S10104453356129	40	32	72	105	100
SK 50 C 20105 AD/6.3 G15000 SL	S10105453355129	50	20	54	105	70
SK 50 C 32105 AD/6.3 G15000 SL	S10105453356129	50	32	72	105	100

Accessories:



Reduction Sleeve (RS)
Ref. Page No. 173

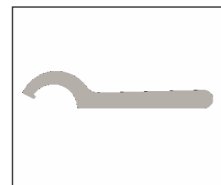

PMC Spanner
Ref. Page No. 154

Note: All Dimensions are in mm

Milling Cutter Armor (MCA)

◆ **Features :**

- For Mounting of Screw type Modular Milling Cutters.
- Slim Design & hence easy to reach at deep cavities.
- Unibody Construction
- All 'Sigma' Die & Mould Chucks are subjected to Sub-zero treatment (-90° C). This treatment helps to prevent the holders from deformation for many years & hence increases the life.

◆ **Available In Mountings :**

- BT (MAS 403) (DIN ISO 7388 -2)
- BBT (MAS 403)
- SK (DIN 69871) (DIN ISO 7388 - 1)
- HSK-A (DIN 69893-1)
- HSK-F (DIN 69893-6)

◆ **Balancing :**

- Balanced To 2.5 G 25000 RPM



SK-(DIN-69871) (DIN ISO 7388- 1)
Milling Cutter Arbor (MCA)

Maximum Run out of the Internal Dia with respect to the External Taper 0.005 mm

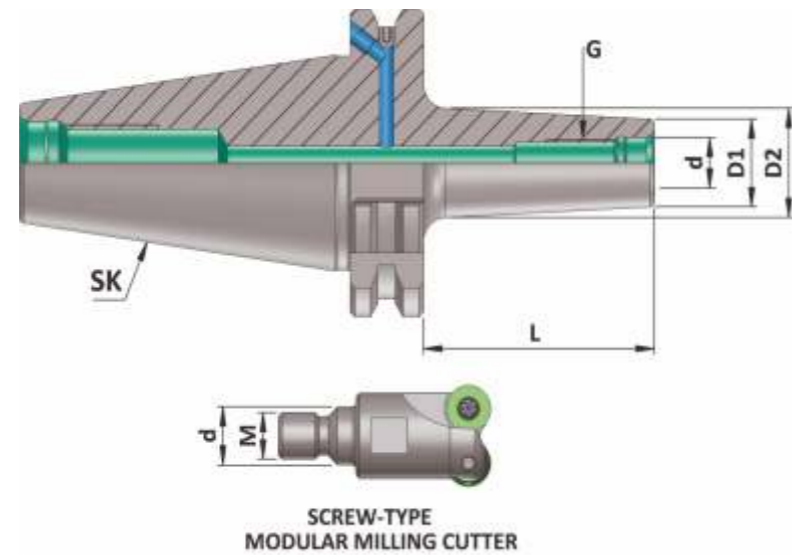

SK (DIN 69871)
 DIN ISO 7388 - 1 Holders

SK (DIN 69871) (MCA)

(Balanced to 2.5 G 25000 RPM)

Item Name	Item Code	SK	d	D1	D2	G	L
SK 40 MCA06 025 AD+B/2.5G 25000 SL	S10104137101230	40	6.5	10	13	M6	25
SK 40 MCA06 050 AD+B/2.5G 25000 SL	S10104137111230	40	6.5	10	20	M6	50
SK 40 MCA06 075 AD+B/2.5G 25000 SL	S10104137127230	40	6.5	10	23	M6	75
SK 40 MCA08 025 AD+B/2.5G 25000 SL	S10104138101230	40	8.5	13	15	M8	25
SK 40 MCA08 050 AD+B/2.5G 25000 SL	S10104138111230	40	8.5	13	23	M8	50
SK 40 MCA08 075 AD+B/2.5G 25000 SL	S10104138127230	40	8.5	13	23	M8	75
SK 40 MCA08 100 AD+B/2.5G 25000 SL	S10104138148230	40	8.5	13	25	M8	100
SK 40 MCA10 025 AD+B/2.5G 25000 SL	S10104139101230	40	10.5	18	20	M10	25
SK 40 MCA10 050 AD+B/2.5G 25000 SL	S10104139111230	40	10.5	18	23	M10	50
SK 40 MCA10 075 AD+B/2.5G 25000 SL	S10104139127230	40	10.5	18	28	M10	75
SK 40 MCA10 100 AD+B/2.5G 25000 SL	S10104139148230	40	10.5	18	32	M10	100
SK 40 MCA12 025 AD+B/2.5G 25000 SL	S10104140101230	40	12.5	21	24	M12	25
SK 40 MCA12 050 AD+B/2.5G 25000 SL	S10104140111230	40	12.5	21	24	M12	50
SK 40 MCA12 075 AD+B/2.5G 25000 SL	S10104140127230	40	12.5	21	31	M12	75
SK 40 MCA12 100 AD+B/2.5G 25000 SL	S10104140148230	40	12.5	21	33	M12	100
SK 40 MCA12 125 AD+B/2.5G 25000 SL	S10104140164230	40	12.5	21	36	M12	125
SK 40 MCA16 025 AD+B/2.5G 25000 SL	S10104141101230	40	17	29	29	M16	25
SK 40 MCA16 050 AD+B/2.5G 25000 SL	S10104141111230	40	17	29	34	M16	50
SK 40 MCA16 075 AD+B/2.5G 25000 SL	S10104141127230	40	17	29	34	M16	75
SK 40 MCA16 100 AD+B/2.5G 25000 SL	S10104141148230	40	17	29	36	M16	100
SK 40 MCA16 125 AD+B/2.5G 25000 SL	S10104141164230	40	17	29	40	M16	125
SK 40 MCA16 150 AD+B/2.5G 25000 SL	S10104141173230	40	17	29	42.5	M16	150

Note: All Dimensions are in mm

SK-(DIN-69871) (DIN ISO 7388- 1)
Milling Cutter Arbor (MCA)

Maximum Run out of the Internal Dia with respect to the External Taper 0.005 mm

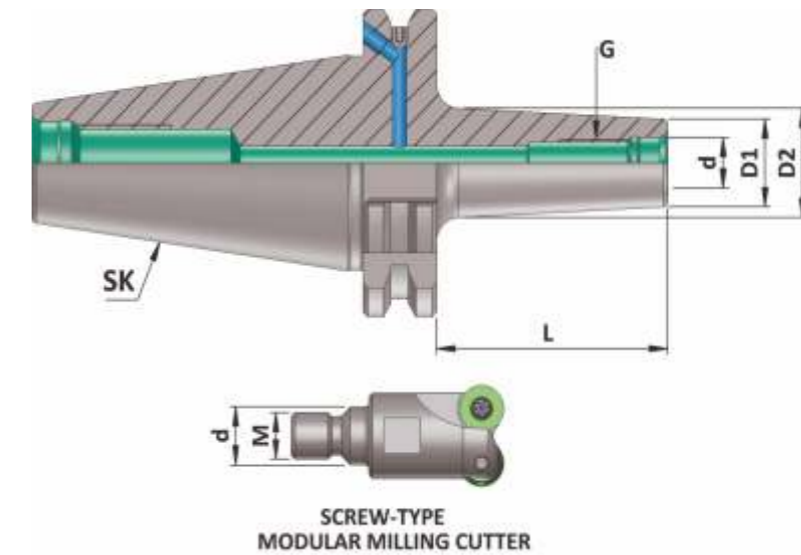

SK (DIN 69871)
 DIN ISO 7388 - 1 Holders

SK (DIN 69871) (MCA)

(Balanced to 2.5 G 25000 RPM)

Item Name	Item Code	SK	d	D1	D2	G	L
SK 50 MCA08 050 AD+B/2.5G 25000 SL	S10105138111230	50	8.5	13	23	M8	50
SK 50 MCA08 100 AD+B/2.5G 25000 SL	S10105138148230	50	8.5	13	25	M8	100
SK 50 MCA08 150 AD+B/2.5G 25000 SL	S10105138173230	50	8.5	13	30	M8	150
SK 50 MCA10 050 AD+B/2.5G 25000 SL	S10105139111230	50	10.5	18	23	M10	50
SK 50 MCA10 100 AD+B/2.5G 25000 SL	S10105139148230	50	10.5	18	32	M10	100
SK 50 MCA10 150 AD+B/2.5G 25000 SL	S10105139173230	50	10.5	18	36.5	M10	150
SK 50 MCA12 050 AD+B/2.5G 25000 SL	S10105140111230	50	12.5	21	24	M12	50
SK 50 MCA12 100 AD+B/2.5G 25000 SL	S10105140148230	50	12.5	21	33	M12	100
SK 50 MCA12 150 AD+B/2.5G 25000 SL	S10105140173230	50	12.5	21	40	M12	150
SK 50 MCA16 050 AD+B/2.5G 25000 SL	S10105141111230	50	17	29	34	M16	50
SK 50 MCA16 100 AD+B/2.5G 25000 SL	S10105141148230	50	17	29	36	M16	100
SK 50 MCA16 150 AD+B/2.5G 25000 SL	S10105141173230	50	17	29	42.5	M16	150

Note: All Dimensions are in mm

Shrink Fit Holder 4.5 Degree (SFH 4.5°)

◆ **Features :**

- For Mounting Of Carbide Drills, End Mills etc.
- Easy to Reach at Deep Cavities.
- Best T. I. R. & Rigidity during long working life, Result of in house Reasearch & Development & special Heat Treatment.

◆ **Available In Mountings :**

- BT (MAS 403) (DIN ISO 7388 - 2)
- BBT (MAS 403)
- SK (DIN 69871) (DIN ISO 7388 - 1)
- HSK-A (DIN 69893-1)
- HSK-F (DIN 69893-6)

◆ **Balancing :**

- Balanced To 2.5 G 25000 RPM



SK (DIN 69871) (DIN ISO 7388- 1) AD/AF Shrink Fit Holder 4.5 Degree (SFH 4.5°) (AD+B)



Maximum Run out of the Internal Dia with respect to the External Taper 0.003 mm

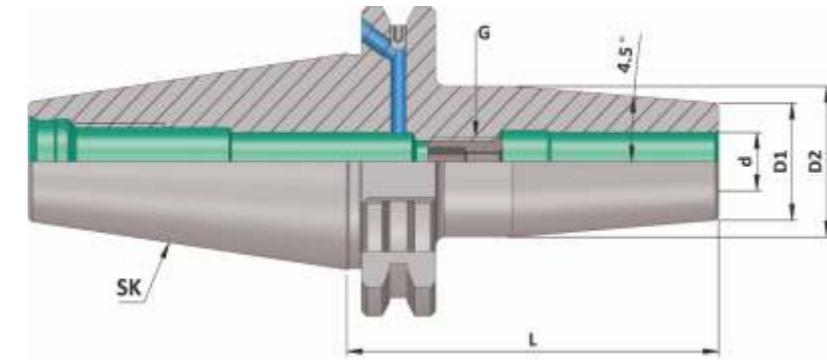

SK (DIN 69871) (SFH 4.5°) (AD+B) AD/AF

(Balanced to 2.5 G 25000 RPM)

Item Name	Item Code	SK	d	D1	D2	G	L
SK 40 SFH03 080 AD+B/2.5G 25000 SL	S10104274131140	40	3	10	20	-	80
SK 40 SFH03 120 AD+B/2.5G 25000 SL	S10104274162140	40	3	10	20	-	120
SK 40 SFH03 160 AD+B/2.5G 25000 SL	S10104274175140	40	3	10	20	-	160
SK 40 SFH04 080 AD+B/2.5G 25000 SL	S10104275131140	40	4	15	22	-	80
SK 40 SFH04 120 AD+B/2.5G 25000 SL	S10104275162140	40	4	15	22	-	120
SK 40 SFH04 160 AD+B/2.5G 25000 SL	S10104275175140	40	4	15	22	-	160
SK 40 SFH05 080 AD+B/2.5G 25000 SL	S10104276131140	40	5	15	22	-	80
SK 40 SFH05 120 AD+B/2.5G 25000 SL	S10104276162140	40	5	15	22	-	120
SK 40 SFH05 160 AD+B/2.5G 25000 SL	S10104276175140	40	5	15	22	-	160
SK 40 SFH06 080 AD+B/2.5G 25000 SL	S10104277131140	40	6	21	27	M5	80
SK 40 SFH06 120 AD+B/2.5G 25000 SL	S10104277162140	40	6	21	27	M5	120
SK 40 SFH06 160 AD+B/2.5G 25000 SL	S10104277175140	40	6	21	27	M5	160
SK 40 SFH08 080 AD+B/2.5G 25000 SL	S10104285131140	40	8	21	27	M6	80
SK 40 SFH08 120 AD+B/2.5G 25000 SL	S10104285162140	40	8	21	27	M6	120
SK 40 SFH08 160 AD+B/2.5G 25000 SL	S10104285175140	40	8	21	27	M6	160
SK 40 SFH10 080 AD+B/2.5G 25000 SL	S10104279131140	40	10	24	31	M8	80
SK 40 SFH10 120 AD+B/2.5G 25000 SL	S10104279162140	40	10	24	31	M8	120
SK 40 SFH10 160 AD+B/2.5G 25000 SL	S10104279175140	40	10	24	31	M8	160
SK 40 SFH12 080 AD+B/2.5G 25000 SL	S10104280131140	40	12	24	31	M10	80
SK 40 SFH12 120 AD+B/2.5G 25000 SL	S10104280162140	40	12	24	31	M10	120
SK 40 SFH12 160 AD+B/2.5G 25000 SL	S10104280175140	40	12	24	31	M10	160
SK 40 SFH14 080 AD+B/2.5G 25000 SL	S10104284131140	40	14	27	34	M10	80
SK 40 SFH14 120 AD+B/2.5G 25000 SL	S10104284162140	40	14	27	34	M10	120
SK 40 SFH14 160 AD+B/2.5G 25000 SL	S10104284175140	40	14	27	34	M10	160
SK 40 SFH16 080 AD+B/2.5G 25000 SL	S10104281131140	40	16	27	34	M12	80
SK 40 SFH16 120 AD+B/2.5G 25000 SL	S10104281162140	40	16	27	34	M12	120
SK 40 SFH16 160 AD+B/2.5G 25000 SL	S10104281175140	40	16	27	34	M12	160
SK 40 SFH18 080 AD+B/2.5G 25000 SL	S10104282131140	40	18	33	40	M12	80
SK 40 SFH18 120 AD+B/2.5G 25000 SL	S10104282162140	40	18	33	40	M12	120
SK 40 SFH18 160 AD+B/2.5G 25000 SL	S10104282175140	40	18	33	40	M12	160

Note: All Dimensions are in mm

SK (DIN 69871)
DIN ISO 7388 - 1 Holders

**SK (DIN 69871) (DIN ISO 7388- 1) AD/AF
Shrink Fit Holder 4.5 Degree (SFH 4.5°) (AD+B)**

Maximum Run out of the Internal Dia with respect to the External Taper 0.003 mm

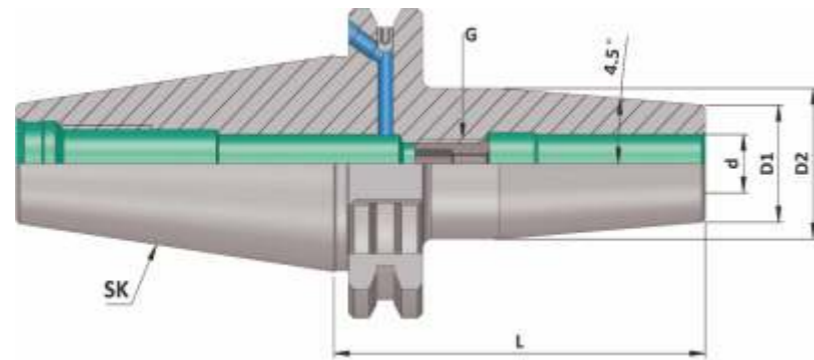

SK (DIN 69871) (SFH 4.5°) (AD+B) AD/AF

(Balanced to 2.5 G 25000 RPM)

Item Name	Item Code	SK	d	D1	D2	G	L
SK 40 SFH20 080 AD+B/2.5G 25000 SL	S10104283131140	40	20	33	40	M16	80
SK 40 SFH20 120 AD+B/2.5G 25000 SL	S10104283162140	40	20	33	40	M16	120
SK 40 SFH20 160 AD+B/2.5G 25000 SL	S10104283175140	40	20	33	40	M16	160
SK 40 SFH25 100 AD+B/2.5G 25000 SL	S10104287148140	40	25	44	53	M16	100
SK 40 SFH25 120 AD+B/2.5G 25000 SL	S10104287162140	40	25	44	53	M16	120
SK 40 SFH25 160 AD+B/2.5G 25000 SL	S10104287175140	40	25	44	53	M16	160
SK 40 SFH32 100 AD+B/2.5G 25000 SL	S10104288148140	40	32	44	53	M16	100
SK 40 SFH32 120 AD+B/2.5G 25000 SL	S10104288162140	40	32	44	53	M16	120
SK 40 SFH32 160 AD+B/2.5G 25000 SL	S10104288175140	40	32	44	53	M16	160

SK 50 SFH03 080 AD+B/2.5G 25000 SL	S10105274131116	50	3	10	20	-	80
SK 50 SFH03 120 AD+B/2.5G 25000 SL	S10105274162116	50	3	10	20	-	120
SK 50 SFH03 160 AD+B/2.5G 25000 SL	S10105274175116	50	3	10	20	-	160
SK 50 SFH04 080 AD+B/2.5G 25000 SL	S10105275131116	50	4	15	22	-	80
SK 50 SFH04 120 AD+B/2.5G 25000 SL	S10105275162116	50	4	15	22	-	120
SK 50 SFH04 160 AD+B/2.5G 25000 SL	S10105275175116	50	4	15	22	-	160
SK 50 SFH05 080 AD+B/2.5G 25000 SL	S10105276131116	50	5	15	22	-	80
SK 50 SFH05 120 AD+B/2.5G 25000 SL	S10105276162116	50	5	15	22	-	120
SK 50 SFH05 160 AD+B/2.5G 25000 SL	S10105276175116	50	5	15	22	-	160
SK 50 SFH06 080 AD+B/2.5G 25000 SL	S10105277131116	50	6	21	27	M5	80
SK 50 SFH06 120 AD+B/2.5G 25000 SL	S10105277162116	50	6	21	27	M5	120
SK 50 SFH06 160 AD+B/2.5G 25000 SL	S10105277175116	50	6	21	27	M5	160
SK 50 SFH08 080 AD+B/2.5G 25000 SL	S10105285131116	50	8	21	27	M6	80
SK 50 SFH08 120 AD+B/2.5G 25000 SL	S10105285162116	50	8	21	27	M6	120
SK 50 SFH08 160 AD+B/2.5G 25000 SL	S10105285175116	50	8	21	27	M6	160
SK 50 SFH10 080 AD+B/2.5G 25000 SL	S10105279131116	50	10	24	31	M8	80
SK 50 SFH10 120 AD+B/2.5G 25000 SL	S10105279162116	50	10	24	31	M8	120
SK 50 SFH10 160 AD+B/2.5G 25000 SL	S10105279175116	50	10	24	31	M8	160
SK 50 SFH12 080 AD+B/2.5G 25000 SL	S10105280131116	50	12	24	31	M10	80
SK 50 SFH12 120 AD+B/2.5G 25000 SL	S10105280162116	50	12	24	31	M10	120
SK 50 SFH12 160 AD+B/2.5G 25000 SL	S10105280175116	50	12	24	31	M10	160

Note: All Dimensions are in mm

Continued...

**SK (DIN 69871) (DIN ISO 7388- 1) AD/AF
Shrink Fit Holder 4.5 Degree (SFH 4.5°) (AD+B)**

Maximum Run out of the Internal Dia with respect to the External Taper 0.003 mm

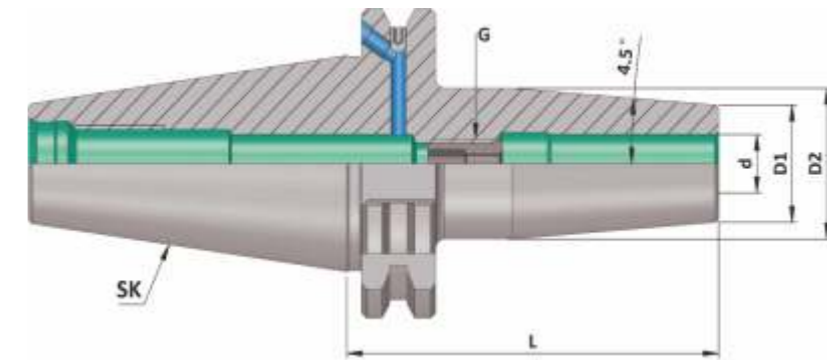

SK (DIN 69871) (SFH 4.5°) (AD+B) AD/AF

(Balanced to 2.5 G 25000 RPM)

Item Name	Item Code	SK	d	D1	D2	G	L
SK 50 SFH14 080 AD+B/2.5G 25000 SL	S10105284131116	50	14	27	34	M10	80
SK 50 SFH14 120 AD+B/2.5G 25000 SL	S10105284162116	50	14	27	34	M10	120
SK 50 SFH14 160 AD+B/2.5G 25000 SL	S10105284175116	50	14	27	34	M10	160
SK 50 SFH16 080 AD+B/2.5G 25000 SL	S10105281131116	50	16	27	34	M12	80
SK 50 SFH16 120 AD+B/2.5G 25000 SL	S10105281162116	50	16	27	34	M12	120
SK 50 SFH16 160 AD+B/2.5G 25000 SL	S10105281175116	50	16	27	34	M12	160
SK 50 SFH18 080 AD+B/2.5G 25000 SL	S10105282131116	50	18	33	40	M12	80
SK 50 SFH18 120 AD+B/2.5G 25000 SL	S10105282162116	50	18	33	40	M12	120
SK 50 SFH18 160 AD+B/2.5G 25000 SL	S10105282175116	50	18	33	40	M12	160
SK 50 SFH20 080 AD+B/2.5G 25000 SL	S10105283131116	50	20	33	40	M16	80
SK 50 SFH20 120 AD+B/2.5G 25000 SL	S10105283162116	50	20	33	40	M16	120
SK 50 SFH20 160 AD+B/2.5G 25000 SL	S10105283175116	50	20	33	40	M16	160
SK 50 SFH25 100 AD+B/2.5G 25000 SL	S10105287148116	50	25	44	53	M16	100
SK 50 SFH25 120 AD+B/2.5G 25000 SL	S10105287162116	50	25	44	53	M16	120
SK 50 SFH25 160 AD+B/2.5G 25000 SL	S10105287175116	50	25	44	53	M16	160
SK 50 SFH32 100 AD+B/2.5G 25000 SL	S10105288148116	50	32	44	53	M16	100
SK 50 SFH32 120 AD+B/2.5G 25000 SL	S10105288162116	50	32	44	53	M16	120
SK 50 SFH32 160 AD+B/2.5G 25000 SL	S10105288175116	50	32	44	53	M16	160

Note: All Dimensions are in mm

SK (DIN 69871) (DIN ISO 7388- 1) AD/AF
Shrink Fit Holder 4.5 Degree (Face Coolant Channel)
(SFH 4.5°) (FCC) (AD+B)

Maximum Run out of the Internal Dia with respect to the External Taper 0.003 mm

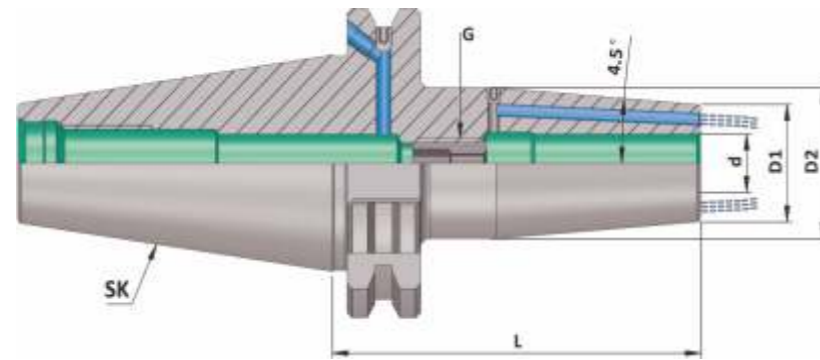

SK (DIN 69871) (SFH FCC 4.5°) (AD+B) AD/ AF

(Balanced to 2.5 G 25000 RPM)

Item Name	Item Code	SK	d	D1	D2	G	L
SK40 SFH03 080 FCC AD+B/2.5G 25000 SL	S10104274131255	40	3	10	20	-	80
SK40 SFH03 120 FCC AD+B/2.5G 25000 SL	S10104274162255	40	3	10	20	-	120
SK40 SFH03 160 FCC AD+B/2.5G 25000 SL	S10104274175255	40	3	10	20	-	160
SK40 SFH04 080 FCC AD+B/2.5G 25000 SL	S10104275131255	40	4	15	22	-	80
SK40 SFH04 120 FCC AD+B/2.5G 25000 SL	S10104275162255	40	4	15	22	-	120
SK40 SFH04 160 FCC AD+B/2.5G 25000 SL	S10104275175255	40	4	15	22	-	160
SK40 SFH05 080 FCC AD+B/2.5G 25000 SL	S10104276131255	40	5	15	22	-	80
SK40 SFH05 120 FCC AD+B/2.5G 25000 SL	S10104276162255	40	5	15	22	-	120
SK40 SFH05 160 FCC AD+B/2.5G 25000 SL	S10104276175255	40	5	15	22	-	160
SK40 SFH06 080 FCC AD+B/2.5G 25000 SL	S10104277131255	40	6	21	27	M5	80
SK40 SFH06 120 FCC AD+B/2.5G 25000 SL	S10104277162255	40	6	21	27	M5	120
SK40 SFH06 160 FCC AD+B/2.5G 25000 SL	S10104277175255	40	6	21	27	M5	160
SK40 SFH08 080 FCC AD+B/2.5G 25000 SL	S10104285131255	40	8	21	27	M6	80
SK40 SFH08 120 FCC AD+B/2.5G 25000 SL	S10104285162255	40	8	21	27	M6	120
SK40 SFH08 160 FCC AD+B/2.5G 25000 SL	S10104285175255	40	8	21	27	M6	160
SK40 SFH10 080 FCC AD+B/2.5G 25000 SL	S10104279131255	40	10	24	31	M8	80
SK40 SFH10 120 FCC AD+B/2.5G 25000 SL	S10104279162255	40	10	24	31	M8	120
SK40 SFH10 160 FCC AD+B/2.5G 25000 SL	S10104279175255	40	10	24	31	M8	160
SK40 SFH12 080 FCC AD+B/2.5G 25000 SL	S10104280131255	40	12	24	31	M10	80
SK40 SFH12 120 FCC AD+B/2.5G 25000 SL	S10104280162255	40	12	24	31	M10	120
SK40 SFH12 160 FCC AD+B/2.5G 25000 SL	S10104280175255	40	12	24	31	M10	160

Note: All Dimensions are in mm

Continued...

SK (DIN 69871) (DIN ISO 7388- 1) AD/AF
Shrink Fit Holder 4.5 Degree (Face Coolant Channel)
(SFH 4.5°) (FCC) (AD+B)

Maximum Run out of the Internal Dia with respect to the External Taper 0.003 mm

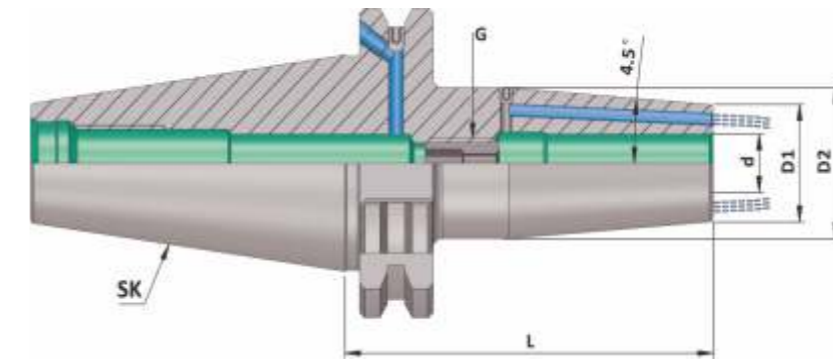

SK (DIN 69871) (SFH FCC 4.5°) (AD+B) AD/ AF

(Balanced to 2.5 G 25000 RPM)

Item Name	Item Code	SK	d	D1	D2	G	L
SK40 SFH14 080 FCC AD+B/2.5G 25000 SL	S10104284131255	40	14	27	34	M10	80
SK40 SFH14 120 FCC AD+B/2.5G 25000 SL	S10104284162255	40	14	27	34	M10	120
SK40 SFH14 160 FCC AD+B/2.5G 25000 SL	S10104284175255	40	14	27	34	M10	160
SK40 SFH16 080 FCC AD+B/2.5G 25000 SL	S10104281131255	40	16	27	34	M12	80
SK40 SFH16 120 FCC AD+B/2.5G 25000 SL	S10104281162255	40	16	27	34	M12	120
SK40 SFH16 160 FCC AD+B/2.5G 25000 SL	S10104281175255	40	16	27	34	M12	160
SK40 SFH18 080 FCC AD+B/2.5G 25000 SL	S10104282131255	40	18	33	40	M12	80
SK40 SFH18 120 FCC AD+B/2.5G 25000 SL	S10104282162255	40	18	33	40	M12	120
SK40 SFH18 160 FCC AD+B/2.5G 25000 SL	S10104282175255	40	18	33	40	M12	160
SK40 SFH20 080 FCC AD+B/2.5G 25000 SL	S10104283131255	40	20	33	40	M16	80
SK40 SFH20 120 FCC AD+B/2.5G 25000 SL	S10104283162255	40	20	33	40	M16	120
SK40 SFH20 160 FCC AD+B/2.5G 25000 SL	S10104283175255	40	20	33	40	M16	160
SK40 SFH25 100 FCC AD+B/2.5G 25000 SL	S10104287148255	40	25	44	53	M16	100
SK40 SFH25 120 FCC AD+B/2.5G 25000 SL	S10104287162255	40	25	44	53	M16	120
SK40 SFH25 160 FCC AD+B/2.5G 25000 SL	S10104287175255	40	25	44	53	M16	160
SK40 SFH32 100 FCC AD+B/2.5G 25000 SL	S10104288148255	40	32	44	53	M16	100
SK40 SFH32 120 FCC AD+B/2.5G 25000 SL	S10104288162255	40	32	44	53	M16	120
SK40 SFH32 160 FCC AD+B/2.5G 25000 SL	S10104288175255	40	32	44	53	M16	160

Note: All Dimensions are in mm

SK (DIN 69871) (DIN ISO 7388- 1) AD/AF
Shrink Fit Holder 4.5 Degree (Face Coolant Channel)
(SFH 4.5°) (FCC) (AD+B)

Maximum Run out of the Internal Dia with respect to the External Taper 0.003 mm

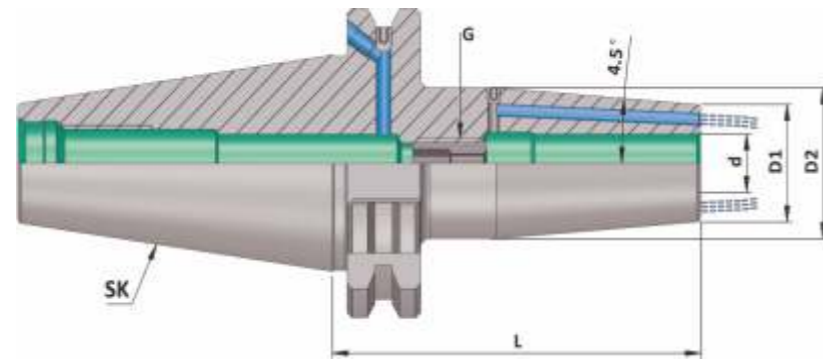

SK (DIN 69871) (SFH FCC 4.5°) (AD+B) AD/ AF

(Balanced to 2.5 G 25000 RPM)

Item Name	Item Code	SK	d	D1	D2	G	L
SK50 SFH03 080 FCC AD+B/2.5G 25000 SL	S10105274131255	50	3	10	20	-	80
SK50 SFH03 120 FCC AD+B/2.5G 25000 SL	S10105274162255	50	3	10	20	-	120
SK50 SFH03 160 FCC AD+B/2.5G 25000 SL	S10105274175255	50	3	10	20	-	160
SK50 SFH04 080 FCC AD+B/2.5G 25000 SL	S10105275131255	50	4	15	22	-	80
SK50 SFH04 120 FCC AD+B/2.5G 25000 SL	S10105275162255	50	4	15	22	-	120
SK50 SFH04 160 FCC AD+B/2.5G 25000 SL	S10105275175255	50	4	15	22	-	160
SK50 SFH05 080 FCC AD+B/2.5G 25000 SL	S10105276131255	50	5	15	22	-	80
SK50 SFH05 120 FCC AD+B/2.5G 25000 SL	S10105276162255	50	5	15	22	-	120
SK50 SFH05 160 FCC AD+B/2.5G 25000 SL	S10105276175255	50	5	15	22	-	160
SK50 SFH06 080 FCC AD+B/2.5G 25000 SL	S10105277131255	50	6	21	27	M5	80
SK50 SFH06 120 FCC AD+B/2.5G 25000 SL	S10105277162255	50	6	21	27	M5	120
SK50 SFH06 160 FCC AD+B/2.5G 25000 SL	S10105277175255	50	6	21	27	M5	160
SK50 SFH08 080 FCC AD+B/2.5G 25000 SL	S10105285131255	50	8	21	27	M6	80
SK50 SFH08 120 FCC AD+B/2.5G 25000 SL	S10105285162255	50	8	21	27	M6	120
SK50 SFH08 160 FCC AD+B/2.5G 25000 SL	S10105285175255	50	8	21	27	M6	160
SK50 SFH10 080 FCC AD+B/2.5G 25000 SL	S10105279131255	50	10	24	31	M8	80
SK50 SFH10 120 FCC AD+B/2.5G 25000 SL	S10105279162255	50	10	24	31	M8	120
SK50 SFH10 160 FCC AD+B/2.5G 25000 SL	S10105279175255	50	10	24	31	M8	160
SK50 SFH12 080 FCC AD+B/2.5G 25000 SL	S10105280131255	50	12	24	31	M10	80
SK50 SFH12 120 FCC AD+B/2.5G 25000 SL	S10105280162255	50	12	24	31	M10	120
SK50 SFH12 160 FCC AD+B/2.5G 25000 SL	S10105280175255	50	12	24	31	M10	160

Note: All Dimensions are in mm

Continued...

SK (DIN 69871) (DIN ISO 7388- 1) AD/AF
Shrink Fit Holder 4.5 Degree (Face Coolant Channel)
(SFH 4.5°) (FCC) (AD+B)

Maximum Run out of the Internal Dia with respect to the External Taper 0.003 mm

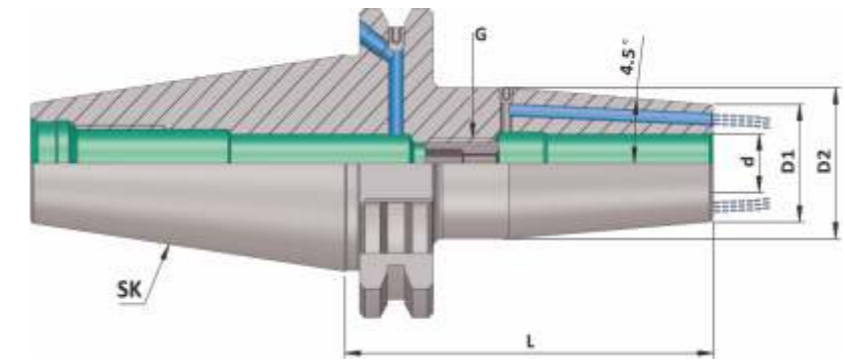

SK (DIN 69871) (SFH FCC 4.5°) (AD+B) AD/ AF

(Balanced to 2.5 G 25000 RPM)

Item Name	Item Code	SK	d	D1	D2	G	L
SK50 SFH14 080 FCC AD+B/2.5G 25000 SL	S10105284131255	50	14	27	34	M10	80
SK50 SFH14 120 FCC AD+B/2.5G 25000 SL	S10105284162255	50	14	27	34	M10	120
SK50 SFH14 160 FCC AD+B/2.5G 25000 SL	S10105284175255	50	14	27	34	M10	160
SK50 SFH16 080 FCC AD+B/2.5G 25000 SL	S10105281131255	50	16	27	34	M12	80
SK50 SFH16 120 FCC AD+B/2.5G 25000 SL	S10105281162255	50	16	27	34	M12	120
SK50 SFH16 160 FCC AD+B/2.5G 25000 SL	S10105281175255	50	16	27	34	M12	160
SK50 SFH18 080 FCC AD+B/2.5G 25000 SL	S10105282131255	50	18	33	40	M12	80
SK50 SFH18 120 FCC AD+B/2.5G 25000 SL	S10105282162255	50	18	33	40	M12	120
SK50 SFH18 160 FCC AD+B/2.5G 25000 SL	S10105282175255	50	18	33	40	M12	160
SK50 SFH20 080 FCC AD+B/2.5G 25000 SL	S10105283131255	50	20	33	40	M16	80
SK50 SFH20 120 FCC AD+B/2.5G 25000 SL	S10105283162255	50	20	33	40	M16	120
SK50 SFH20 160 FCC AD+B/2.5G 25000 SL	S10105283175255	50	20	33	40	M16	160
SK50 SFH25 100 FCC AD+B/2.5G 25000 SL	S10105287148255	50	25	44	53	M16	100
SK50 SFH25 120 FCC AD+B/2.5G 25000 SL	S10105287162255	50	25	44	53	M16	120
SK50 SFH25 160 FCC AD+B/2.5G 25000 SL	S10105287175255	50	25	44	53	M16	160
SK50 SFH32 100 FCC AD+B/2.5G 25000 SL	S10105288148255	50	32	44	53	M16	100
SK50 SFH32 120 FCC AD+B/2.5G 25000 SL	S10105288162255	50	32	44	53	M16	120
SK50 SFH32 160 FCC AD+B/2.5G 25000 SL	S10105288175255	50	32	44	53	M16	160

Note: All Dimensions are in mm

Minimum Length Compensation Tapping Chuck (MLC)

◆ Features :

- Sigma "Minimum Length Compensation Tapping Chuck (MLC)" For Synchronised (Rigid) Tapping Cycle.
- Best suitable for Die & Mould Industry.
- Compression & Expansion +/- 0.5mm
- High Concentricity Enables High Speed Tapping.
- Positive Clamping Through ER Tap Collet.

◆ Technical Details :

- "MLC" Tapping Chucks to be used with CNC Machines, having Synchronised Tapping cycle.
- In this case, Rigid Tapping cycle takes care of tap pitch controlling the feed, spindle speed and feed. So, theoretically, ordinary holder without any compensation also should be suitable for performing the process.
- ◆ But by law of theory, following factors they do affect tapping quality, tap life etc.
 1. Dynamics of machine
 2. Synchronisation of spindle speed & feed.
 3. During Change of Spindle, Rotational direction and feed direction.
 4. Pitch error on Tap / Tolerance on Pitch

◆ This will lead to :

1. Less Tap life because of Flank wear (one side)
2. Damaged Flanks on threads on the work piece
3. Threads not answering to Gauge.

◆ All above errors can be taken care by using ' MLC '

◆ Sigma 'MLC' Tapping Chucks with +/- 0.5 mm compensation.

◆ Available In Following Range :

- ER 16 : M3 to M12
- ER 20 : M3 to M16
- ER 25 : M3 to M20
- ER 32 : M4 to M27
- ER 40 : M6 to M33

◆ Available In Mountings :

- HSK- A (DIN 69893-1)
- BT (MAS 403) (DIN ISO 7388 - 2)
- BBT (MAS 403)
- SK (DIN 69871) (DIN ISO 7388 - 1)
- Cylindrical Shank

◆ Balancing :

- Main Body Balanced to 2.5G 25000 RPM



SK (DIN 69871) (DIN ISO 7388- 1) Minimum Length Compensation Tapping Chuck (MLC)

SIGMA
TOOLINGS

Maximum Run out of the Internal Taper with respect to the External Taper 0.020 mm

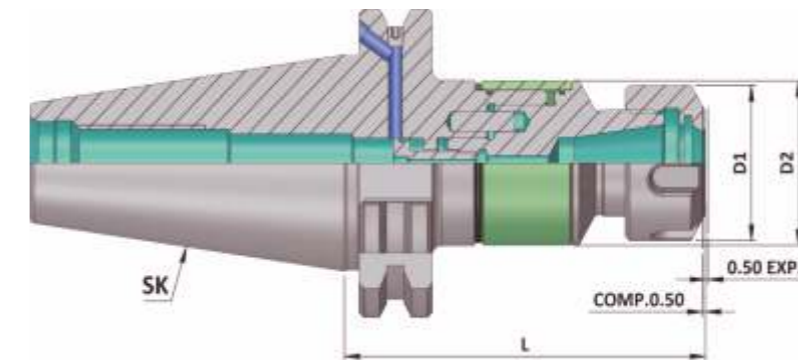

SK (DIN 69871) (MLC)

Item Name	Item Code	SK	Capacity	Clamping Range	Nut Size	D1	D2	L	Comp.	Exp.
SK 40 ER 16M 079 AD+B MLC	S10104157551245	40	M3-M12	1-10	ER 16M	22	34	79		0.5
SK 40 ER 16 079 AD+B MLC	S10104149551245	40	M3-M12	1-10	ER 16	32	34	79		0.5
SK 40 ER 20 080 AD+B MLC	S10104150131250	40	M3-M16	3.5-10	ER 20	35	34	80		0.5
SK 40 ER 25 084 AD+B MLC	S10104151134245	40	M3-M20	3.5-16	ER 25	42	34	84		0.5
SK 40 ER 32 095 AD+B MLC	S10104152145245	40	M4-M27	3.5-20	ER 32	50	45	95		0.5
SK 40 ER 40 120 AD+B MLC	S10104153162245	40	M6-M33	6-26	ER 40	63	62	120		0.5

SK 50 ER 16M 079 AD+B MLC	S10105157551250	50	M3-M12	1-10	ER 16M	22	34	79		0.5
SK 50 ER 16 079 AD+B MLC	S10105149551245	50	M3-M12	1-10	ER 16	32	34	79		0.5
SK 50 ER 20 080 AD+B MLC	S10105150131250	50	M3-M16	3.5-10	ER 20	35	34	80		0.5
SK 50 ER 25 084 AD+B MLC	S10105151134245	50	M3-M20	3.5-16	ER 25	42	34	84		0.5
SK 50 ER 32 095 AD+B MLC	S10105152145245	50	M4-M27	3.5-20	ER 32	50	45	95		0.5
SK 50 ER 40 105 AD+B MLC	S10105153152245	50	M6-M33	6-26	ER 40	63	62	105		0.5

Accessories:



Tap Collet ER G
Ref. Page No. 169-171



Q.C. Tap Collet QCTC
Ref. Page No. 174-182



ER Nut
Ref. Page No. 151-152









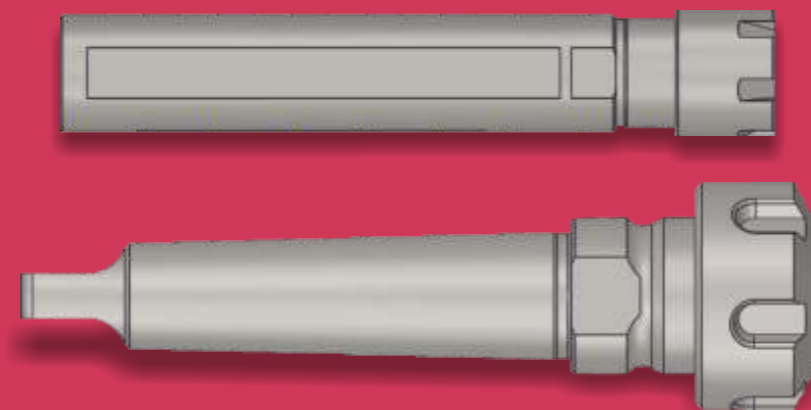

ER Spanner
Ref. Page No. 153

Note: All Dimensions are in mm

Precision Tool Holders & Tapping Chucks with Cylindrical Shank & Morse Taper Shank



INDEX

Sr. No.	Contents		Page No.
1	Cylindrical Collet Chuck ER (DIN 6499)		134
2	Cylindrical Collet Chuck ER- M Type (DIN 6499)		135
3	Cylindrical Die & Mould Chuck (DMC)		136
4	Cylindrical Shrink Fit Holder (SFH 4.5°) (Shrinking Extention)		137
5	Cylindrical Floating Reamer Holder (FRH)		138 - 139
6	Minimum Length Compensation Tapping Chuck (MLC)		140
7	Quick Change Tapping Chucks (KWFLK) <ul style="list-style-type: none"> • Cylindrical Shank KWFLK • VDI Shank KWFLK 		141 - 142
8	Quick Change Tapping Chucks 'Q' Series <ul style="list-style-type: none"> • Cylindrical Type 'Q' Series (External) • Cylindrical Type 'Q' Series (Internal) 		143
9	Precision Tool Holders With Morse Taper Shank <ul style="list-style-type: none"> • MT (DIN 228 B) Collet Chuck ER (DIN 6499) • MT (DIN 228 A) Collet Chuck ER (DIN 6499) • MT (DIN 228 B) Quick Change Tapping Chuck (KWFLK) • MT (DIN 228 B) Quick Change Tapping Chuck 'Q' Series 		144 - 147

Cylindrical Shank Die & Mould Chuck (DMC)

Maximum Run out of the Internal Taper with respect to the External Diameter < 0.005 mm

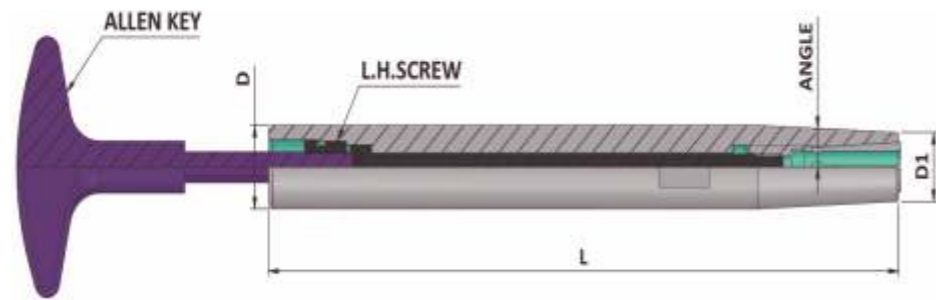

Cylindrical (DMC)

Item Name	Item Code	Gripping Range	D	D1	L	Angle	Collet	Screw	Allen Key
D16 DMC 06 L 150	S10118161236127	3-6	16	13	150	3	DMC-6	M5	4X200
D20 DMC 06 L 200	S10119161237127	3-6	20	13	200	3	DMC-6	M5	4X200
D25 DMC 06 L 250	S10120161256127	3-6	25	13	250	3	DMC-6	M5	4X200
D20 DMC 08 L 150	S10119162236127	3-8	20	19	150	3	DMC-8	M6	5X200
D20 DMC 08 L 200	S10119162237127	3-8	20	19	200	3	DMC-8	M6	5X200
D25 DMC 10 L 150	S10120163236127	3-10	25	24	150	3	DMC-10	M8	6X200
D25 DMC 10 L 200	S10120163237127	3-10	25	24	200	3	DMC-10	M8	6X200
D25 DMC 10 L 250	S10120163256127	3-10	25	24	250	3	DMC-10	M8	6X200

Accessories:



DMC Collet
Ref. Page No. 172

Note: All Dimensions are in mm

Cylindrical Shank Shrink Fit Holder 4.5 Degree (Shrinking Extension) (SFH 4.5°)

Maximum Run out of the Internal Diameter with respect to the External Diameter 0.003 mm

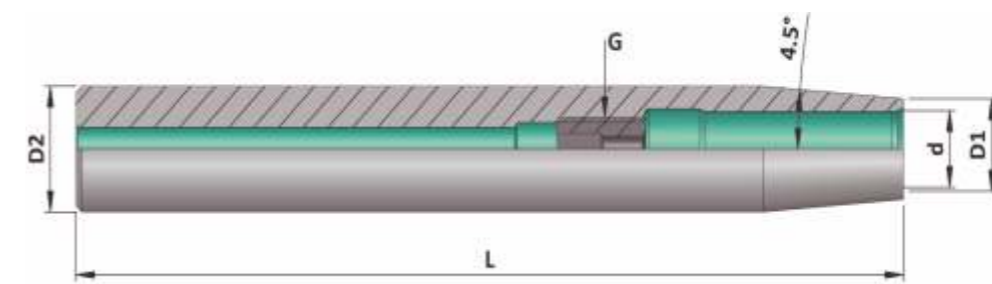

Cylindrical Shank (SFH 4.5°)

Item Name	Item Code	d	D1	D2	G	L
D12 SFH03 150	S10117274173127	3	8	12	-	150
D12 SFH04 150	S10117275173127	4	8	12	-	150
D16 SFH03 150	S10118274173127	3	10	16	-	150
D16 SFH04 150	S10118275173127	4	10	16	-	150
D16 SFH05 150	S10118276173127	5	10	16	-	150
D16 SFH06 150	S10118277173127	6	10	16	M5	150
D20 SFH03 150	S10119274173127	3	10	20	-	150
D20 SFH04 150	S10119275173127	4	10	20	-	150
D20 SFH05 150	S10119276173127	5	10	20	-	150
D20 SFH06 150	S10119277173127	6	10	20	M5	150
D20 SFH08 150	S10119285173127	8	12	20	M6	150
D20 SFH10 150	S10119279173127	10	14	20	M8	150
D20 SFH12 150	S10119280173127	12	16	20	M10	150
D25 SFH08 150	S10120285173127	8	20	25	M6	150
D25 SFH10 150	S10120279173127	10	20	25	M8	150
D25 SFH12 150	S10120280173127	12	20	25	M10	150
D25 SFH14 150	S10120284173127	14	20	25	M10	150
D25 SFH16 150	S10120281173127	16	22	25	M12	150
D32 SFH10 150	S10121279173127	10	24	32	M8	150
D32 SFH12 150	S10121280173127	12	24	32	M10	150
D32 SFH14 150	S10121284173127	14	27	32	M10	150
D32 SFH16 150	S10121281173127	16	27	32	M12	150
D32 SFH18 150	S10121282173127	18	27	32	M12	150
D32 SFH20 150	S10121283173127	20	27	32	M16	150

Note: All Dimensions are in mm

Floating Reamer Holder (FRH)

◆ Features :

- This is a short length Floating Reamer Holder with radial parallel float of 1.0 mm.
- This has got a special mechanism of weight balancing at the end.
- This can be used on any CNC Lathe.
- This solves almost all Reaming problems such as; over size cutting; bell-mouth; surface finish.
- Best suitable for correct size with repeatability; with very good Surface finish.
- This Floating Reamer Holder is with (ER 25 A Collet Chuck)

◆ Range :

- 2.0 to 16.0 mm.

◆ Available In Mounting :

- Available with cylindrical shank Dia. 20, 25 & 32 mm as per DIN 1835 B+E.



Cylindrical Shank (DIN 1835 B+E) Floating Reamer Holder (FRH)

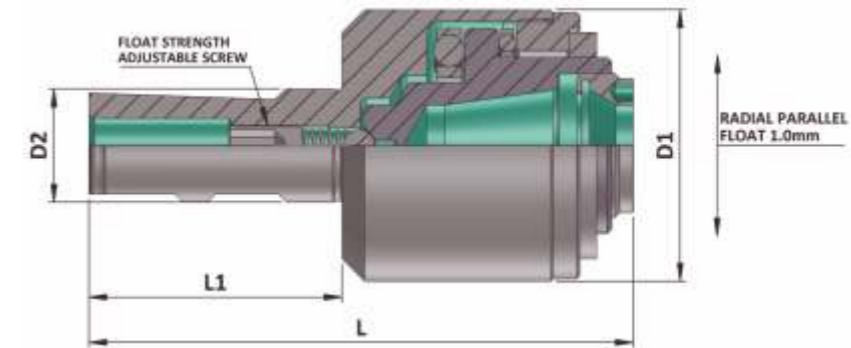

Cylindrical Shank (DIN 1835 B+E) (FRH)

Item Name	Item Code	D1	D2	L	L1	Collet Capacity	Spanner	Radial Parallel Float
FRH DIA 20 ER 25A 116	S10160289302127	60	20	116	51	1 - 16	E25A	1.0mm
FRH DIA 25 ER 25A 121	S10140243240127	60	25	121	56	1 - 16	E25A	1.0mm
FRH DIA 32 ER 25A 126	S10141243263127	60	32	126	61	1 - 16	E25A	1.0mm

Accessories:



Collet ER (DIN 6499)
Ref. Page No. 164-168



ER A Type Nut
Ref. Page No. 151-152

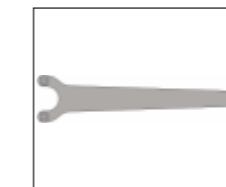

ER A Type Spanner
Ref. Page No. 153

Note: All Dimensions are in mm

**Cylindrical Shank (DIN 1835 B+E)
Minimum Length Compensation Tapping Chuck
(MLC)**

Maximum Run out of the Internal Taper with respect to the External Diameter 0.020 mm

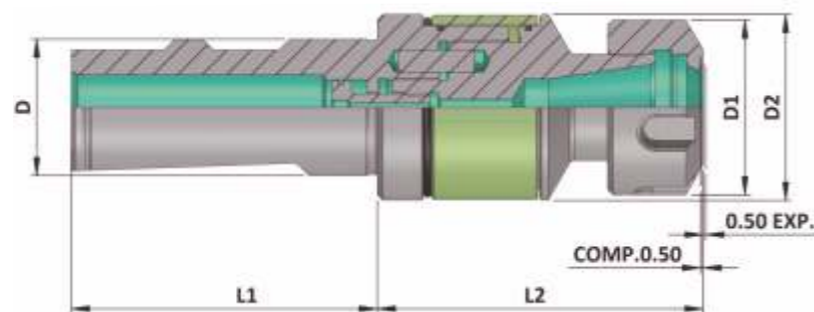

Cylindrical Shank (DIN 1835 B+E) (MLC)

Item Name	Item Code	Capacity	Clamping Range	Nut Size	D	D1	D2	L1	L2	Comp.	Exp.
D20 ER 16M L 58 MLC	S10119157552245	M3-M12	1-10	ER 16M	20	22	34	51	58	0.5	0.5
D20 ER 16 L 58 MLC	S10119149552245	M3-M12	1-10	ER 16	20	32	34	51	58	0.5	0.5
D25 ER 16M L 60 MLC	S10120157117245	M3-M12	1-10	ER 16M	25	22	34	56	60	0.5	0.5
D25 ER 16 L 60 MLC	S10120149542245	M3-M12	1-10	ER 16	25	32	34	56	60	0.5	0.5
D25 ER 20 L 61 MLC	S10120150561245	M3-M16	3.5-10	ER 20	25	35	34	56	61	0.5	0.5
D25 ER 25 L 65 MLC	S10120151553245	M3-M20	3.5-16	ER 25	25	42	34	56	65	0.5	0.5
D25 ER 32 L 87 MLC	S10120152555245	M4-M27	3.5-20	ER 32	25	50	45	56	87	0.5	0.5
D32 ER 40 L 108.5 MLC	S10121153119245	M6-M33	6-26	ER 40	32	63	62	61	108.5	0.5	0.5

Accessories:



Tap Collet ER-G
Ref. Page No. 164-168



Q.C. Tap Collet QCTC
Ref. Page No. 174-182



ER Nut
Ref. Page No. 151-152



ER Spanner
Ref. Page No. 153

Note: All Dimensions are in mm

**Quick Change Tapping Chuck
With Cylindrical Shank (DIN 1835 B+E)
(KWFLK)**



Cylindrical Shank (DIN 1835 B+E) KWFLK

Item Name	Item Code	Capacity	Suitable Adaptor	Comp.	Exp.	d	D1	D2	L
DIA 16 KWFLK0	S11208267193	M1 - M 10	KWES 0B	6.5	6.5	13	26	16	37
DIA 20 KWFLK0	S11176267193	M1 - M 10	KWES 0B	6.5	6.5	13	26	20	37
DIA 20 KWFLK 1	S11176233193	M3 - M12	KWES 1B	7.5	7.5	19	36	20	40
DIA 25 KWFLK 1	S11177233193	M3 - M12	KWES 1B	7.5	7.5	19	36	25	40
DIA 25 KWFLK 2	S11177234193	M8 - M20	KWES 2B	12.5	12.5	31	53	25	63
DIA 32 KWFLK 1	S11178233193	M3 - M12	KWES 1B	7.5	7.5	19	36	32	40
DIA 32 KWFLK 2	S11178234193	M8 - M20	KWES 2B	12.5	12.5	31	53	32	63
DIA 32 KWFLK 3	S11178235193	M14 - M33	KWES 3B	20	20	48	78	32	125
DIA 40 KWFLK 1	S11179233193	M3 - M12	KWES 1B	7.5	7.5	19	36	40	40
DIA 40 KWFLK 2	S11179234193	M8 - M20	KWES 2B	12.5	12.5	31	53	40	63
DIA 40 KWFLK 3	S11179235193	M14 - M33	KWES 3B	20	20	48	78	40	125
DIA 40 KWFLK 4	S11179236193	M22 - M48	KWES 4B	22.5	22.5	60	96	40	126
DIA 50 KWFLK 4	S11180236193	M22 - M48	KWES 4B	22.5	22.5	60	96	50	126
DIA 3/4" KWFLK 1	S10221169301127	M3 - M12	KWES 1B	7.5	7.5	19	36	3/4"	40
DIA 1" KWFLK 1	S10219169301127	M3 - M12	KWES 1B	7.5	7.5	19	36	1"	40
DIA 1" KWFLK 2	S10219170301127	M8 - M20	KWES 2B	12.5	12.5	31	53	1"	63
DIA 1 - 1/2" KWFLK 3	S11211235193	M14 - M33	KWES 3B	20	20	48	78	1 - 1/2"	125

Accessories:



Tap Adaptor KWES..B & KWESK..B
Ref. Page No. 191-211



Tap Adaptor
Reduction Socket KWRE
Ref. Page No. 212

Note: • All Dimensions are in mm
• For Tap Shank Dimension & Recommended Torque Values Ref. Page No. 281-284

Quick Change Tapping Chuck VDI Shank (KWFLK)

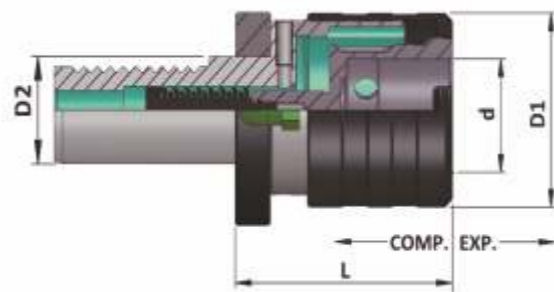

VDI Shank KWFLK

Item Name	Item Code	Capacity	Suitable Adaptor	Comp.	Exp.	d	D1	D2	L
VDI 20 KWFLK1	S10284169522127	M3 - M12	KWES 1B	7.5	7.5	19	36	20	52
VDI 25 KWFLK1	S10285169522127	M3 - M12	KWES 1B	7.5	7.5	19	36	25	52
VDI30 KWFLK1	S10261169522127	M3 - M12	KWES 1B	7.5	7.5	19	36	30	55
VDI40 KWFLK1	S10262169522127	M3 - M12	KWES 1B	7.5	7.5	19	36	40	55
VDI50 KWFLK1	S10263169522127	M3 - M12	KWES 1B	7.5	7.5	19	36	50	55
VDI 25 KWFLK2	S10285170480127	M8 - M20	KWES 2B	12.5	12.5	31	53	25	76
VDI30 KWFLK2	S10261170480127	M8 - M20	KWES 2B	12.5	12.5	31	53	30	76
VDI40 KWFLK2	S10262170480127	M8 - M20	KWES 2B	12.5	12.5	31	53	40	76
VDI50 KWFLK2	S10263170480127	M8 - M20	KWES 2B	12.5	12.5	31	53	50	76
VDI40 KWFLK3	S10262171481127	M14 - M33	KWES 3B	20	20	48	78	40	130
VDI50 KWFLK3	S10263171481127	M14 - M33	KWES 3B	20	20	48	78	50	107

Accessories:



Tap Adaptor KWES..B & KWESK..B
Ref. Page No. 191-211



Tap Adaptor
Reduction Socket KWRE
Ref. Page No. 212



Note: • All Dimensions are in mm
• For Tap Shank Dimension & Recommended Torque Values Ref. Page No. 281-284

Quick Chang Tapping Attachment “Q” Series

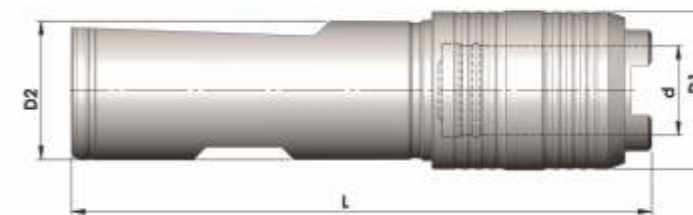

Q (Cylindrical Type)

(No Compression & No Expansion)

Item Name	Item Code	Capacity	Suitable Adaptor	d	D1	D2	L
DIA 16 Q 0	S11208241193	M1-M10	KWESOB/KWEO	13	23	16	33
DIA 20 Q 0	S11176241193	M1-M10	KWESOB/KWEO	13	23	20	33

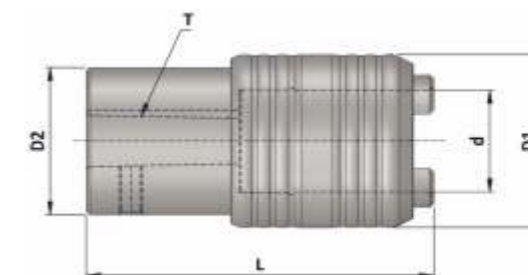

Q (Short Internal Tapper)

(No Compression & No Expansion)

Item Name	Item Code	Capacity	Suitable Adaptor	d	D1	D2	T	L
INTERNAL B12 Q 3-12	S11245266193	M3 - M12	KWES1B / KWE1	19	32	27.9	B12	59
INTERNAL B16 Q 8-20	S11246241225	M8 - M20	KWES2B / KWE2	31	50	44.8	B16	80
INTERNAL B18 Q 8-20	S11247241225	M8 - M20	KWES2B / KWE2	31	50	44.8	B18	88

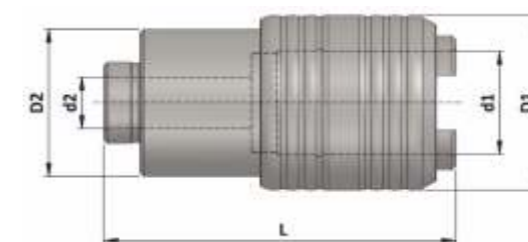

Q (Internal Dia.)

(No Compression & No Expansion)

Item Name	Item Code	Capacity	Suitable Adaptor	d1	d2	D1	D2	L
INTERNAL DIA 16 Q 8-20	S11233241225	M8 - M20	KWES2B / KWE2	31	16	50	44.8	86.5
INTERNAL DIA 25 Q 8-20	S11243241225	M8 - M20	KWES2B / KWE2	31	25	50	44.8	103
INTERNAL DIA 25 Q 14-33	S11243241226	M14 - M33	KWES3B / KWE3	48	25	72	67.4	124.5
INTERNAL DIA 35 Q 22-48	S11258241265	M22 - M48	KWES4B / KWE4	60	35	92	84	139

Note: All Dimensions are in mm
For Necessary Accessories Selection Please refer Page No. 260-280

**Morse Taper (DIN 228 B)
Collet Chuck ER (DIN 6499)**

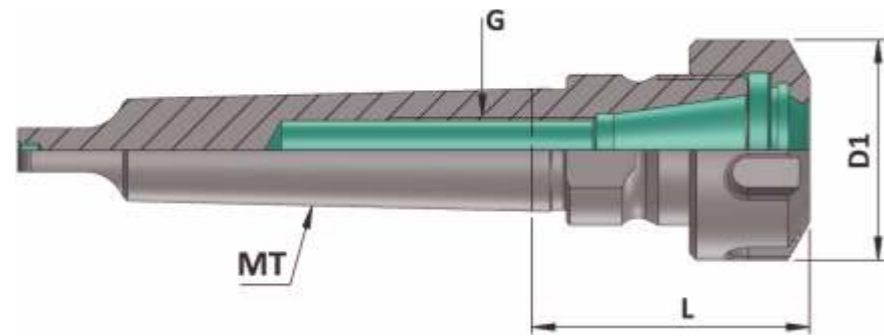

Morse Taper (DIN 228 B) Collet Chuck ER

Item Name	Item Code	D1	G	L	Suitable Collet	Collet Capacity	Nut Size	Spanner
MT 2B ER 16 042	S10129149107127	32	M6	42	ER 16	0.5 - 10	ER 16	E16
MT 2B ER 20 048	S10129150110127	35	M8	48	ER 20	1 - 13	ER 20	E20
MT 3B ER 25 052	S10130151113127	42	M10	52	ER 25	1 - 16	ER 25	E25
MT 3B ER 32 070	S10130152125127	50	M12	70	ER 32	2 - 20	ER 32	E32
MT 4B ER 32 054	S10131152114127	50	M12	54	ER 32	2 - 20	ER 32	E32
MT 4B ER 40 075	S10131153127127	63	M16	75	ER 40	3 - 26	ER 40	E40
MT 4B ER 50 105	S10131154152127	78	M16	105	ER 50	10 - 34	ER 50	E50
MT 5B ER 40 082	S10132153255127	63	M16	82	ER 40	3 - 26	ER 40	E40
MT 5B ER 50 100	S10132154148127	78	M16	100	ER 50	10 - 34	ER 50	E50

Accessories:



Collet ER (DIN 6499)
Ref. Page No. 164-168



ER Nut
Ref. Page No. 151-152

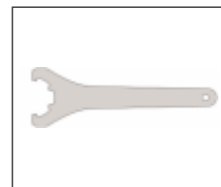

ER Spanner
Ref. Page No. 153

**Morse Taper (DIN 228 A)
Collet Chuck ER (DIN 6499)**

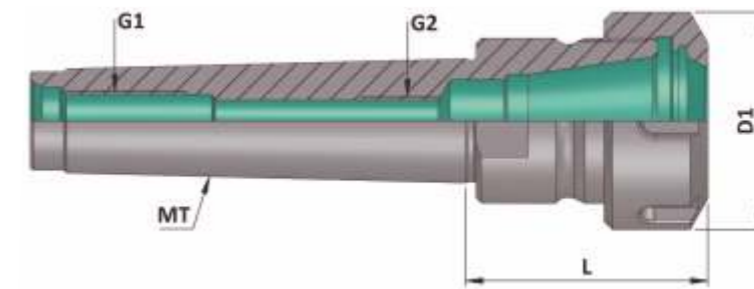

Morse Taper (DIN 228 A) Collet Chuck ER

Item Name	Item Code	D1	G1	G2	L	Suitable Collet	Collet Capacity	Nut Size	Spanner
MT 2A ER 16 042	S10124149107127	32	M10	M6	42	ER 16	0.5 - 10	ER 16	E16
MT 2A ER 20 048	S10124150110127	35	M10	M8	48	ER 20	1 - 13	ER 20	E20
MT 3A ER 25 052	S10125151113127	42	M12	M10	52	ER 25	1 - 16	ER 25	E25
MT 3A ER 32 070	S10125152125127	50	M12	M12	70	ER 32	2 - 20	ER 32	E32
MT 4A ER 32 054	S10126152114127	50	M16	M12	54	ER 32	2 - 20	ER 32	E32
MT 4A ER 40 075	S10126153127127	63	M16	M16	75	ER 40	3 - 26	ER 40	E40
MT 4A ER 50 105	S10126154152127	78	M16	M16	105	ER 50	10 - 34	ER 50	E50
MT 5A ER 40 082	S10127153255127	63	M20	M16	82	ER 40	3 - 26	ER 40	E40
MT 5A ER 50 100	S10127154148127	78	M20	M16	100	ER 50	10 - 34	ER 50	E50

Accessories:



Collet ER (DIN 6499)
Ref. Page No. 164-168



ER Nut Ref. Page No.
Ref. Page No. 151-152

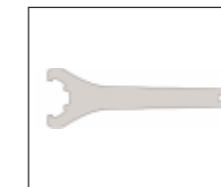

ER Spanner
Ref. Page No. 153

**Morse Taper (DIN 228 B)
Quick Change Tapping Chuck (KWFLK)**

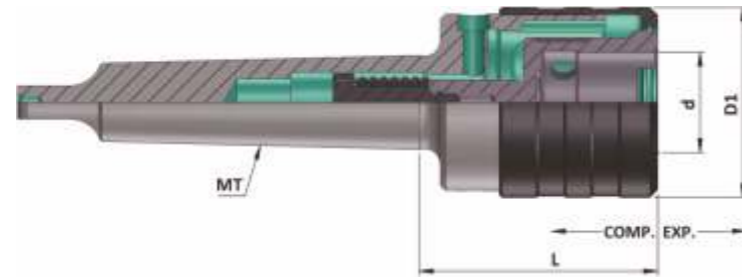

Morse Taper (DIN 228 B) (KWFLK)

Item Name	Item Code	Capacity	Suitable Adaptor	Comp.	Exp.	d	D1	L
MT2B KWFLK1	S11227233193	M3 - M12	KWES1B	7.5	7.5	19	36	47
MT3B KWFLK1	S11228233193	M3 - M12	KWES1B	7.5	7.5	19	36	47
MT3B KWFLK2	S11228234193	M8 - M20	KWES2B	12.5	12.5	31	53	71
MT4B KWFLK2	S11213234193	M8 - M20	KWES2B	12.5	12.5	31	53	72
MT4B KWFLK3	S11213235193	M14 - M33	KWES3B	20	20	48	78	105
MT4B KWFLK3 WITH KEEPER SLOT	S11213235240	M14 - M33	KWES3B	20	20	48	78	105
MT5B KWFLK3	S11215235193	M14 - M33	KWES3B	20	20	48	78	105
MT5B KWFLK3 WITH KEEPER SLOT	S11215235240	M14 - M33	KWES3B	20	20	48	78	105
MT5B KWFLK4	S11215236193	M22 - M48	KWES4B	22.5	22.5	60	96	117

Accessories:



Tap Adaptor KWES..B & KWESK..B
Ref. Page No. 191-211

Tap Adaptor
Reduction Socket KWRE
Ref. Page No. 212

Note: • All Dimensions are in mm
• For Tap Shank Dimension & Recommended Torque Values Ref. Page No. 281-284

**Quick Chang Tapping Attachment
Q (Morse Taper)**



Q (Morse Taper)

(No Compression & No Expansion)

Item Name	Item Code	Capacity	Suitable Adaptor	d	D1	L
MT 2 B Q 3-12	S11201241223	M3 - M12	KWES1B/KWE1	19	32	40
MT 3 B Q 3-12	S11202241223	M3 - M12	KWES1B/KWE1	19	32	40
MT 2 B Q 8-20	S11201241225	M8 - M20	KWES2B/KWE2	31	50	61
MT 3 B Q 8-20	S11202241225	M8 - M20	KWES2B/KWE2	31	50	61

Accessories:

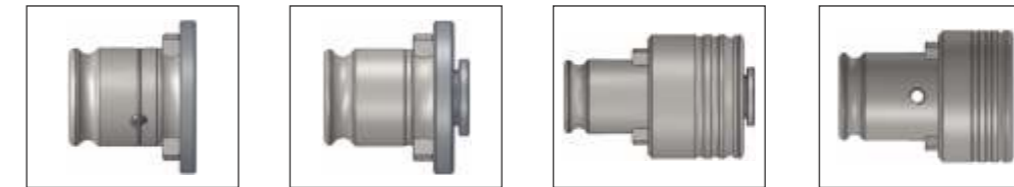

Tap Adaptor
Reduction Socket KWRE
Ref. Page No. 212

Tap Adaptor KWE
Ref. Page No. 183-190







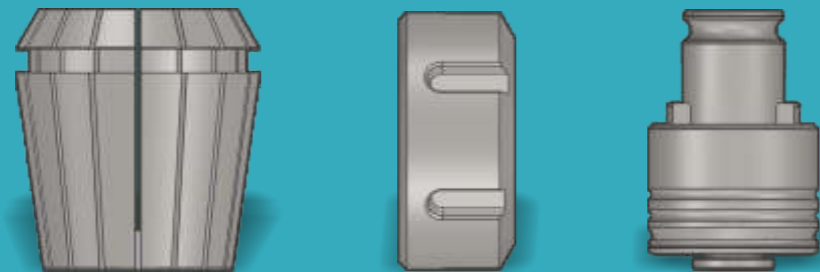











Tap Adaptor KWES..B & KWESK..B
Ref. Page No. 191-211

Note: All Dimensions are in mm
For Tap Shank Dimension & Recommended Torque Values Ref. Page No. 281-284

Accessories for Precision Tool Holders & Tapping Chucks



INDEX

Sr. No.	Contents		Page No.
1	Precision Keyless Drill Chuck & Arbor (DIN 228 B)		150
2	ER Nuts & Spanners		151 - 152
	• ER Series Nuts for Collet Chucks (DIN 6499)		153
	• Spanners for ER Series Collet Chucks		154
	• Spanner for NC Drill Chuck (NCDC)		155 - 156
	• Spanners for Power Milling Chuck (PMC)		155 - 156
	• ER Series Sealed Nuts for Collet Chucks (DIN 6499)		155 - 156
3	Sealing Disc for ER Series Sealed Nuts		157 - 162
4	Accessories for HSK Holders		163
	• Coolant Tube for HSK-A		
	• Spanner for HSK-A		
	• Sealing Plug for HSK-A		
5	Collets		164 - 168
	• Collet ER (DIN 6499)		169 - 171
	• Tap Collet ER-G		172
	• Collet DMC		173
	• Reduction Sleeve (RS)		174 - 182
	• Quick Change Tap Collet (QCTC)		174 - 182
6	Quick Change Tap Adaptor		183 - 190
	• KWE		191 - 208
	• KWES.. / B		209 - 211
	• KWESK.. / B		212
	• KWRE		212
7	Technical Information		213 - 216
	• Tap Shank Dimensions (ISO 529 / DIN / JIS / ANSI)		
	• Recommended Torque Values		
8	Pull Studs		217 - 218
	• BT / ISO / MAZAK / SK		

Precision Key Less Drill Chuck & Arbor

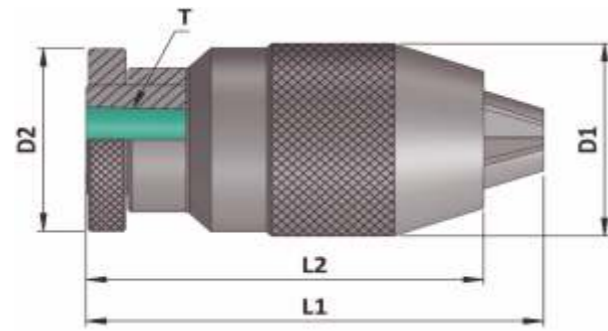

Precision Key Less Drill Chuck

Item Name	Item Code	D1	D2	T	L1	L2
DC 0 - 6.5 B12	S10150246301127	34	34	B12	68	61.5
DC 0 - 6.5 J1	S10150247301127	34	34	J1	68	61.5
DC 1 - 13 B16	S10151249301127	50	48	B16	103	90.5
DC 1 - 13 J6	S10151160301127	50	48	J6	103	90.5

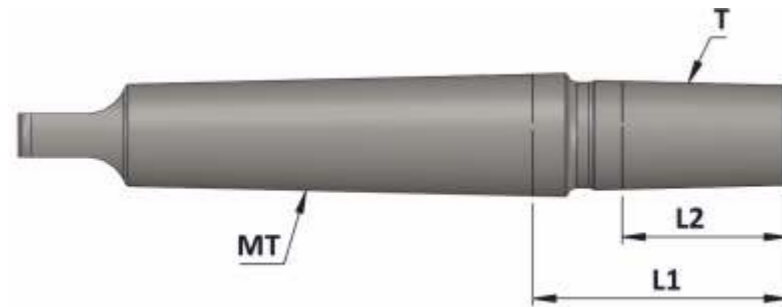

Precision Arbor (DIN 228 B)

Item Name	Item Code	T	Morse Tapre (MT)	L1	L2
ARBOR MT1B J1	S10198496318127	J1	MT 1	27.7	16.7
ARBOR MT2B J1	S10198373318127	J1	MT 2	29.5	16.7
ARBOR MT2B J6	S10198373319127	J6	MT 2	38.5	25.4

ER Series Nuts for Collet Chucks(DIN 6499)

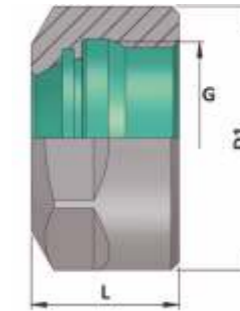

Hex. Nut ER

Item Name	Item Code	D1	G	L	Suitable Spanner
UM ER 11 HEX	S10183273271139	19	M14 x 0.75	11.3	GS 17
UM ER 16 HEX	S10183273272139	28	M22 x 1.50	17.5	GS 25
UM ER 20 HEX	S10183150541127	34	M25 x 1.50	19	GS 30

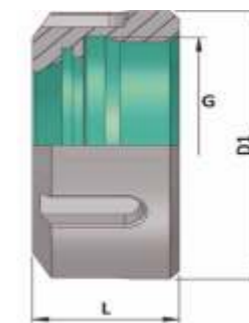

UM ER Slotted Nut

Item Name	Item Code	D1	G	L	Suitable Spanner
UM ER 16 SLOTTED	S10183273272134	32	M22 x 1.5	17.50	E16
UM ER 20 SLOTTED	S10183273273134	35	M25 x 1.5	19	E20
UM ER 25 SLOTTED	S10183273274134	42	M32 x 1.5	20	E25
UM ER 32 SLOTTED	S10183273275134	50	M40 x 1.5	22.50	E32
UM ER 40 SLOTTED	S10183273276134	63	M50 x 1.5	25.50	E40
UM ER 50 SLOTTED	S10183273277134	78	M64 x 2	35	E50

ER Series Nuts for Collet Chucks(DIN 6499)

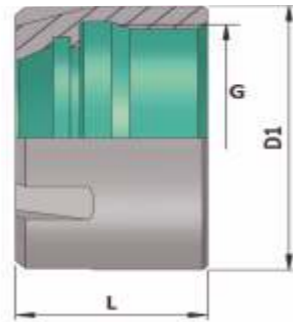

UM ER M Slotted Nut

Item Name	Item Code	D1	G	L	Suitable Spanner
UM ER 8 M	S10183273270136	12	M10 x 0.75	11	E8M
UM ER 11 M	S10183273271136	16	M13 x 0.75	11.50	E11M
UM ER 16 M	S10183273272136	22	M19 x 1.0	17.50	E16M
UM ER 20 M	S10183273273136	28	M24 x 1.0	19	E20M
UM ER 25 M	S10183273274136	35	M30 x 1.0	20	E25M

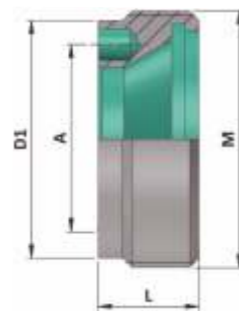

UM ER A Nut

Item Name	Item Code	D1	A	M	L	Suitable Spanner
UM ER 25 A	S10183243301127	29.50	23.60	M32 x 1.5	12.5	E25A
UM ER 32 A	S10183244301127	37	31.85	M40 x 1.5	18.5	E32A

Spanners for ER Series Collet Chucks

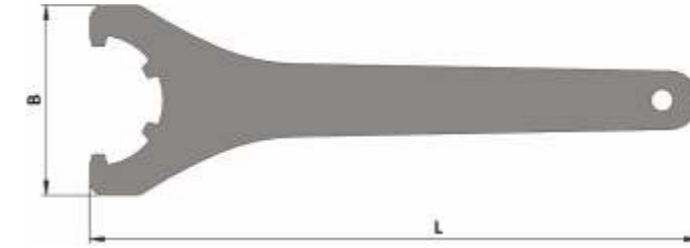

Spanner Type (E)

Item Name	Item Code	B	L	Suitable Nut
SPANNER E16	S10184355301127	50	160	UM/ER16
SPANNER E20	S10184356301127	55	180	UM/ER20
SPANNER E25	S10184357301127	65	210	UM/ER25
SPANNER E32	S10184358301127	75	250	UM/ER32
SPANNER E40	S10184359301127	90	290	UM/ER40
SPANNER E50	S10184360301127	110	350	UM/ER50

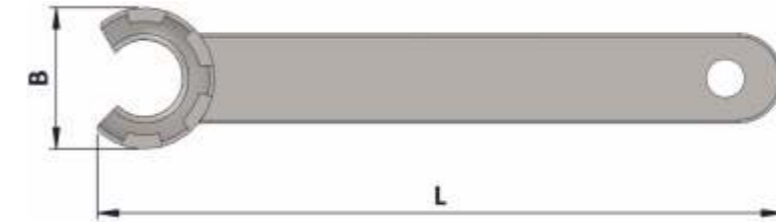

Spanner Type (EM) (Mini)

Item Name	Item Code	B	L	Suitable Nut
SPANNER E 8M	S10184398301127	12.4	70	UM/ER8M
SPANNER E11M	S10184399301127	16.8	90	UM/ER11M
SPANNER E16M	S10184400301127	22.5	110	UM/ER16M
SPANNER E20M	S10184401301127	29	120	UM/ER20M
SPANNER E25M	S10184402301127	36	130	UM/ER25M

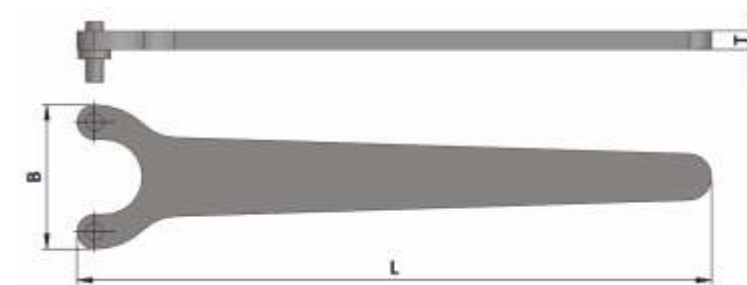

Spanner Type (ER A)

Item Name	Item Code	T	B	L	Suitable Nut
SPANNER E25 A	S10184487301127	4	31	130	UM/ER25A
SPANNER E32 A	S10184488301127	5	42	150	UM/ER32A

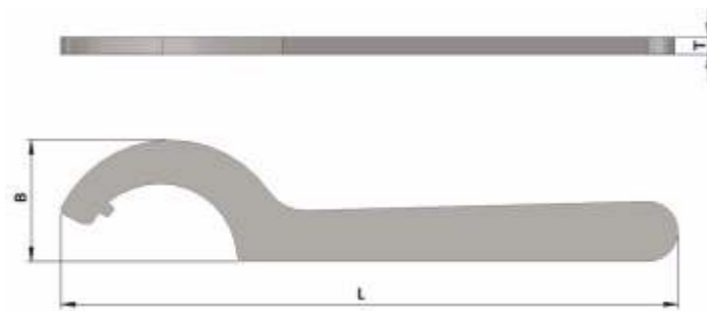

Spanner For (NCDC)

Item Name	Item Code	T	B	L	Suitable Chuck
SPANNER for NCDC	S10184167301127	5	48	176	NCDC 1-13

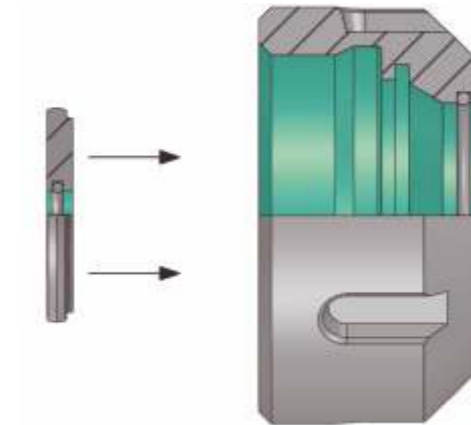

Technical Information :

Sealing Nuts along with Sealing Disc has a compact design with very short extension of clamping nuts which gives the following benefits.

- 1) It protects against all kind of dirt and chips entering the slots of the collet.
- 2) Coolant through tools can be used, which gives improved cooling and lubrication of tools and hence increases the tool life.
- 3) Improved chip removal.
- 4) Sealing Disc are available from $\varnothing 3.0$ mm in range of 0.5mm. Hence easy changing of Sealing Disk according to required application.
- 5) No need of expensive sealed collets. Regular collets are best suitable.

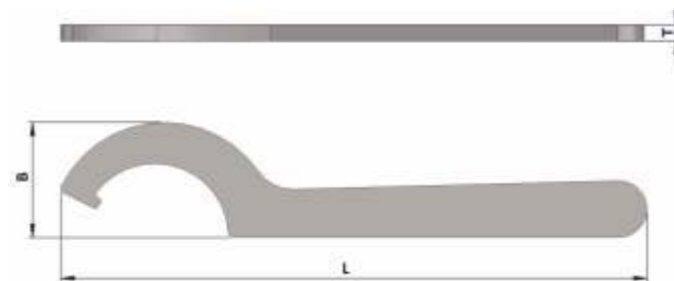

Spanner For (PMC)

Item Name	Item Code	T	B	L	Suitable Chuck
SPANNER C-20	S10184445301127	6	42.50	216	PMC C-20
SPANNER C-32	S10184446301127	6	53	288	UM/ER32A

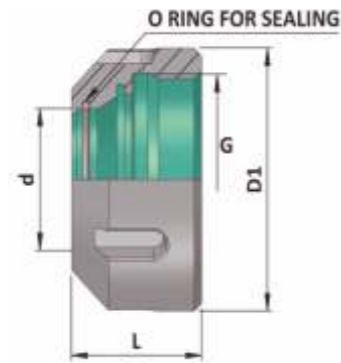

UM ER Sealed Nut

Item Name	Item Code	d	D1	G	L	Suitable Spanner
UM ER 16 S	S10183273272135	13	32	M22 x 1.5	22.5	E16
UM ER 20 S	S10183273273135	16	35	M25 x 1.5	24	E20
UM ER 25 S	S10183273274135	21	42	M32 x 1.5	25	E25
UM ER 32 S	S10183273275135	27	50	M40 x 1.5	27.5	E32
UM ER 40 S	S10183273276135	33.5	63	M50 x 1.5	30.5	E40
UM ER 50 S	S10183273277135	43.5	78	M64 x 2	42.5	E50

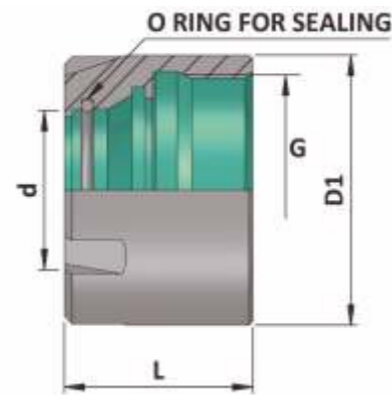

UM ER M Sealed Nut

Item Name	Item Code	d	D1	G	L	Suitable Spanner
UM ER 16 MS	S10183273272137	13	22	M19 x 1.0	22	E16M
UM ER 20 MS	S10183273273137	16	28	M24 x 1.0	24	E20M
UM ER 25 MS	S10183273274137	21	35	M30 x 1.0	25	E25M

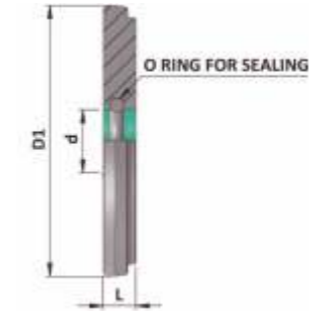

Technical Information

Item Name	D1	Holding Rang (d)	L
SEALING DISC ER 16	13	3.0 - 10	4
SEALING DISC ER 20	16	3.0 - 13	4
SEALING DISC ER 25	21	3.0 - 16	4
SEALING DISC ER 32	27	3.0 - 20	4
SEALING DISC ER 40	33	3.0 - 26	4
SEALING DISC ER 50	43.5	6 - 32.5	4.5

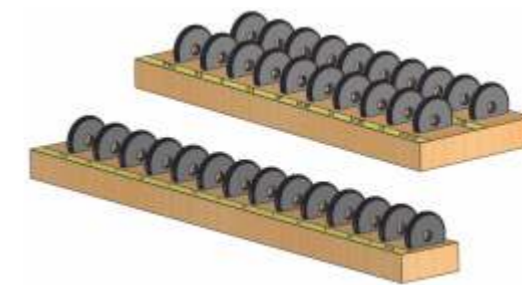

Set Of Sealing Disc

Item Name	Item Code	Clamping Range	PCS / SET
SET OF SEALING DISC ER 16 3.0 - 10MM	S10256149294127	3.0 - 10	14 Nos
SET OF SEALING DISC ER 20 3.0 - 13MM	S10256150295127	3.0 - 13	20 Nos
SET OF SEALING DISC ER 25 3.0 - 16MM	S10256151296127	3.0 - 16	26 Nos
SET OF SEALING DISC ER 32 3.0 - 20MM	S10256152297127	3.0 - 20	34 Nos
SET OF SEALING DISC ER 40 3.0 - 26MM	S10256153298127	3.0 - 26	46 Nos

Sealing Disc For Sealed Nut (ER-S & ER-MS)

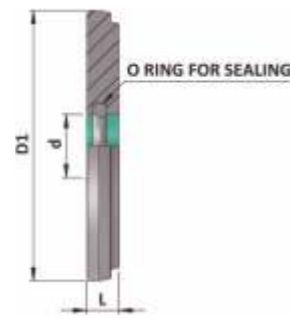

Sealing Disc ER 16

Item Name	Item Code	Suitable Nut	d	D1	L	'O' Ring Size
SEALING DISC ER 16 3.00 - 3.50	S10152149185127	ER 16 S / ER 16 MS	3.00 - 3.50	13	4	2.80X1.50
SEALING DISC ER 16 3.50 - 4.00	S10152149186127	ER 16 S / ER 16 MS	3.50 - 4.00	13	4	3.30X1.50
SEALING DISC ER 16 4.00 - 4.50	S10152149187127	ER 16 S / ER 16 MS	4.00 - 4.50	13	4	3.80X1.50
SEALING DISC ER 16 4.50 - 5.00	S10152149188127	ER 16 S / ER 16 MS	4.50 - 5.00	13	4	4.30X1.50
SEALING DISC ER 16 5.00 - 5.50	S10152149189127	ER 16 S / ER 16 MS	5.00 - 5.50	13	4	4.80X1.50
SEALING DISC ER 16 5.50 - 6.00	S10152149190127	ER 16 S / ER 16 MS	5.50 - 6.00	13	4	5.30X1.50
SEALING DISC ER 16 6.00 - 6.50	S10152149191127	ER 16 S / ER 16 MS	6.00 - 6.50	13	4	5.80X1.50
SEALING DISC ER 16 6.50 - 7.00	S10152149192127	ER 16 S / ER 16 MS	6.50 - 7.00	13	4	6.30X1.50
SEALING DISC ER 16 7.00 - 7.50	S10152149193127	ER 16 S / ER 16 MS	7.00 - 7.50	13	4	6.80X1.50
SEALING DISC ER 16 7.50 - 8.00	S10152149194127	ER 16 S / ER 16 MS	7.50 - 8.00	13	4	7.30X1.50
SEALING DISC ER 16 8.00 - 8.50	S10152149195127	ER 16 S / ER 16 MS	8.00 - 8.50	13	4	7.80X1.50
SEALING DISC ER 16 8.50 - 9.00	S10152149196127	ER 16 S / ER 16 MS	8.50 - 9.00	13	4	8.30X1.50
SEALING DISC ER 16 9.00 - 9.50	S10152149197127	ER 16 S / ER 16 MS	9.00 - 9.50	13	4	8.80X1.0
SEALING DISC ER 16 9.50 - 10.00	S10152149198127	ER 16 S / ER 16 MS	9.50 - 10.00	13	4	9.30X1.0

Sealing Disc ER 20

SEALING DISC ER 20 3.00 - 3.50	S10152150185127	ER 20 S / ER 20 MS	3.00 - 3.50	16	4	2.80X1.50
SEALING DISC ER 20 3.50 - 4.00	S10152150186127	ER 20 S / ER 20 MS	3.50 - 4.00	16	4	3.30X1.50
SEALING DISC ER 20 4.00 - 4.50	S10152150187127	ER 20 S / ER 20 MS	4.00 - 4.50	16	4	3.80X1.50
SEALING DISC ER 20 4.50 - 5.00	S10152150188127	ER 20 S / ER 20 MS	4.50 - 5.00	16	4	4.30X1.50
SEALING DISC ER 20 5.00 - 5.50	S10152150189127	ER 20 S / ER 20 MS	5.00 - 5.50	16	4	4.80X1.50
SEALING DISC ER 20 5.50 - 6.00	S10152150190127	ER 20 S / ER 20 MS	5.50 - 6.00	16	4	5.30X1.50
SEALING DISC ER 20 6.00 - 6.50	S10152150191127	ER 20 S / ER 20 MS	6.00 - 6.50	16	4	5.80X1.50
SEALING DISC ER 20 6.50 - 7.00	S10152150192127	ER 20 S / ER 20 MS	6.50 - 7.00	16	4	6.30X1.50
SEALING DISC ER 20 7.00 - 7.50	S10152150193127	ER 20 S / ER 20 MS	7.00 - 7.50	16	4	6.80X1.50
SEALING DISC ER 20 7.50 - 8.00	S10152150194127	ER 20 S / ER 20 MS	7.50 - 8.00	16	4	7.30X1.50
SEALING DISC ER 20 8.00 - 8.50	S10152150195127	ER 20 S / ER 20 MS	8.00 - 8.50	16	4	7.80X1.50
SEALING DISC ER 20 8.50 - 9.00	S10152150196127	ER 20 S / ER 20 MS	8.50 - 9.00	16	4	8.30X1.50
SEALING DISC ER 20 9.00 - 9.50	S10152150197127	ER 20 S / ER 20 MS	9.00 - 9.50	16	4	8.80X1.50
SEALING DISC ER 20 9.50 - 10.00	S10152150198127	ER 20 S / ER 20 MS	9.50 - 10.00	16	4	9.30X1.50
SEALING DISC ER 20 10.00 - 10.50	S10152150199127	ER 20 S / ER 20 MS	10.00 - 10.50	16	4	9.80X1.50
SEALING DISC ER 20 10.50 - 11.00	S10152150200127	ER 20 S / ER 20 MS	10.50 - 11.00	16	4	10.30X1.50
SEALING DISC ER 20 11.00 - 11.50	S10152150201127	ER 20 S / ER 20 MS	11.00 - 11.50	16	4	10.80X1.50
SEALING DISC ER 20 11.50 - 12.00	S10152150202127	ER 20 S / ER 20 MS	11.50 - 12.00	16	4	11.30X1.50
SEALING DISC ER 20 12.00 - 12.50	S10152150203127	ER 20 S / ER 20 MS	12.00 - 12.50	16	4	11.80X1.0
SEALING DISC ER 20 12.50 - 13.00	S10152150204127	ER 20 S / ER 20 MS	12.50 - 13.00	16	4	12.30X1.0

Sealing Disc For Sealed Nut (ER-S & ER-MS)

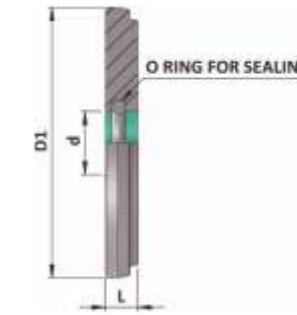

Sealing Disc ER 25

Item Name	Item Code	Suitable Nut	d	D1	L	'O' Ring Size
SEALING DISC ER 25 3.00 - 3.50	S10152151185127	ER 25 S / ER 25 MS	3.00 - 3.50	21	4	2.80X1.50
SEALING DISC ER 25 3.50 - 4.00	S10152151186127	ER 25 S / ER 25 MS	3.50 - 4.00	21	4	3.30X1.50
SEALING DISC ER 25 4.00 - 4.50	S10152151187127	ER 25 S / ER 25 MS	4.00 - 4.50	21	4	3.80X1.50
SEALING DISC ER 25 4.50 - 5.00	S10152151188127	ER 25 S / ER 25 MS	4.50 - 5.00	21	4	4.30X1.50
SEALING DISC ER 25 5.00 - 5.50	S10152151189127	ER 25 S / ER 25 MS	5.00 - 5.50	21	4	4.80X1.50
SEALING DISC ER 25 5.50 - 6.00	S10152151190127	ER 25 S / ER 25 MS	5.50 - 6.00	21	4	5.30X1.50
SEALING DISC ER 25 6.00 - 6.50	S10152151191127	ER 25 S / ER 25 MS	6.00 - 6.50	21	4	5.80X1.50
SEALING DISC ER 25 6.50 - 7.00	S10152151192127	ER 25 S / ER 25 MS	6.50 - 7.00	21	4	6.30X1.50
SEALING DISC ER 25 7.00 - 7.50	S10152151193127	ER 25 S / ER 25 MS	7.00 - 7.50	21	4	6.80X1.50
SEALING DISC ER 25 7.50 - 8.00	S10152151194127	ER 25 S / ER 25 MS	7.50 - 8.00	21	4	7.30X1.50
SEALING DISC ER 25 8.00 - 8.50	S10152151195127	ER 25 S / ER 25 MS	8.00 - 8.50	21	4	7.80X1.50
SEALING DISC ER 25 8.50 - 9.00	S10152151196127	ER 25 S / ER 25 MS	8.50 - 9.00	21	4	8.30X1.50
SEALING DISC ER 25 9.00 - 9.50	S10152151197127	ER 25 S / ER 25 MS	9.00 - 9.50	21	4	8.80X1.50
SEALING DISC ER 25 9.50 - 10.00	S10152151198127	ER 25 S / ER 25 MS	9.50 - 10.00	21	4	9.30X1.50
SEALING DISC ER 25 10.00 - 10.50	S10152151199127	ER 25 S / ER 25 MS	10.00 - 10.50	21	4	9.80X1.50
SEALING DISC ER 25 10.50 - 11.00	S10152151200127	ER 25 S / ER 25 MS	10.50 - 11.00	21	4	10.30X1.50
SEALING DISC ER 25 11.00 - 11.50	S10152151201127	ER 25 S / ER 25 MS	11.00 - 11.50	21	4	10.80X1.50
SEALING DISC ER 25 11.50 - 12.00	S10152151202127	ER 25 S / ER 25 MS	11.50 - 12.00	21	4	11.30X1.50
SEALING DISC ER 25 12.00 - 12.50	S10152151203127	ER 25 S / ER 25 MS	12.00 - 12.50	21	4	11.80X1.50
SEALING DISC ER 25 12.50 - 13.00	S10152151204127	ER 25 S / ER 25 MS	12.50 - 13.00	21	4	12.30X1.50
SEALING DISC ER 25 13.00 - 13.50	S10152151305127	ER 25 S / ER 25 MS	13.00 - 13.50	21	4	12.80X1.50
SEALING DISC ER 25 13.50 - 14.00	S10152151205127	ER 25 S / ER 25 MS	13.50 - 14.00	21	4	13.30X1.50
SEALING DISC ER 25 14.00 - 14.50	S10152151206127	ER 25 S / ER 25 MS	14.00 - 14.50	21	4	13.80X1.50
SEALING DISC ER 25 14.50 - 15.00	S10152151207127	ER 25 S / ER 25 MS	14.50 - 15.00	21	4	14.30X1.50
SEALING DISC ER 25 15.00 - 15.50	S10152151208127	ER 25 S / ER 25 MS	15.00 - 15.50	21	4	14.80X1.50
SEALING DISC ER 25 15.50 - 16.00	S10152151209127	ER 25 S / ER 25 MS	15.50 - 16.00	21	4	15.30X1.50

Sealing Disc For Sealed Nut (ER-S)

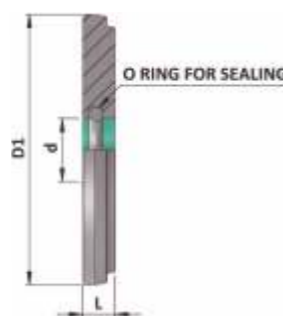

Sealing Disc ER 32

Item Name	Item Code	Suitable Nut	d	D1	L	'O' Ring Size
SEALING DISC ER 32 3.00 - 3.50	S10152152185127	ER 32 S	3.00 - 3.50	27	4	2.80X1.50
SEALING DISC ER 32 3.50 - 4.00	S10152152186127	ER 32 S	3.50 - 4.00	27	4	3.30X1.50
SEALING DISC ER 32 4.00 - 4.50	S10152152187127	ER 32 S	4.00 - 4.50	27	4	3.80X1.50
SEALING DISC ER 32 4.50 - 5.00	S10152152188127	ER 32 S	4.50 - 5.00	27	4	4.30X1.50
SEALING DISC ER 32 5.00 - 5.50	S10152152189127	ER 32 S	5.00 - 5.50	27	4	4.80X1.50
SEALING DISC ER 32 5.50 - 6.00	S10152152190127	ER 32 S	5.50 - 6.00	27	4	5.30X1.50
SEALING DISC ER 32 6.00 - 6.50	S10152152191127	ER 32 S	6.00 - 6.50	27	4	5.80x1.50
SEALING DISC ER 32 6.50 - 7.00	S10152152192127	ER 32 S	6.50 - 7.00	27	4	6.30x1.50
SEALING DISC ER 32 7.00 - 7.50	S10152152193127	ER 32 S	7.00 - 7.50	27	4	6.80x1.50
SEALING DISC ER 32 7.50 - 8.00	S10152152194127	ER 32 S	7.50 - 8.00	27	4	7.30X1.50
SEALING DISC ER 32 8.00 - 8.50	S10152152195127	ER 32 S	8.00 - 8.50	27	4	7.80X1.50
SEALING DISC ER 32 8.50 - 9.00	S10152152196127	ER 32 S	8.50 - 9.00	27	4	8.30X1.50
SEALING DISC ER 32 9.00 - 9.50	S10152152197127	ER 32 S	9.00 - 9.50	27	4	8.80X1.50
SEALING DISC ER 32 9.50 - 10.00	S10152152198127	ER 32 S	9.50 - 10.00	27	4	9.30X1.50
SEALING DISC ER 32 10.00 - 10.50	S10152152199127	ER 32 S	10.00 - 10.50	27	4	9.80X1.50
SEALING DISC ER 32 10.50 - 11.00	S10152152200127	ER 32 S	10.50 - 11.00	27	4	10.30X1.50
SEALING DISC ER 32 11.00 - 11.50	S10152152201127	ER 32 S	11.00 - 11.50	27	4	10.80X1.50
SEALING DISC ER 32 11.50 - 12.00	S1015215220212	ER 32 S	11.50 - 12.00	27	4	11.30X1.50
SEALING DISC ER 32 12.00 - 12.50	S10152152203127	ER 32 S	12.00 - 12.50	27	4	11.80X1.50
SEALING DISC ER 32 12.50 - 13.00	S10152152204127	ER 32 S	12.50 - 13.00	27	4	12.30X1.50
SEALING DISC ER 32 13.00 - 13.50	S10152152305127	ER 32 S	13.00 - 13.50	27	4	12.80X1.50
SEALING DISC ER 32 13.50 - 14.00	S10152152205127	ER 32 S	13.50 - 14.00	27	4	13.30X1.50
SEALING DISC ER 32 14.00 - 14.50	S10152152206127	ER 32 S	14.00 - 14.50	27	4	13.80X1.50
SEALING DISC ER 32 14.50 - 15.00	S10152152207127	ER 32 S	14.50 - 15.00	27	4	14.30X1.50
SEALING DISC ER 32 15.00 - 15.50	S10152152208127	ER 32 S	15.00 - 15.50	27	4	14.80X1.50
SEALING DISC ER 32 15.50 - 16.00	S10152152209127	ER 32 S	15.50 - 16.00	27	4	15.30X1.50
SEALING DISC ER 32 16.00 - 16.50	S10152152210127	ER 32 S	16.00 - 16.50	27	4	15.80X1.50
SEALING DISC ER 32 16.50 - 17.00	S10152152211127	ER 32 S	16.50 - 17.00	27	4	16.30X1.50
SEALING DISC ER 32 17.00 - 17.50	S10152152212127	ER 32 S	17.00 - 17.50	27	4	16.80X1.50
SEALING DISC ER 32 17.50 - 18.00	S10152152213127	ER 32 S	17.50 - 18.00	27	4	17.30X1.50
SEALING DISC ER 32 18.00 - 18.50	S10152152214127	ER 32 S	18.00 - 18.50	27	4	17.80X1.50
SEALING DISC ER 32 18.50 - 19.00	S10152152215127	ER 32 S	18.50 - 19.00	27	4	18.30X1.50
SEALING DISC ER 32 19.00 - 19.50	S10152152216127	ER 32 S	19.00 - 19.50	27	4	18.80X1.50
SEALING DISC ER 32 19.50 - 20.00	S10152152217127	ER 32 S	19.50 - 20.00	27	4	19.30X1.50

Note: All Dimensions are in mm

Sealing Disc For Sealed Nut (ER-S)

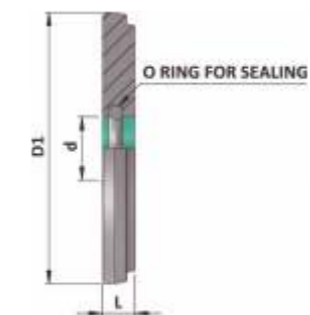

Sealing Disc ER 40

Item Name	Item Code	Suitable Nut	d	D1	L	'O' Ring Size
SEALING DISC ER 40 3.00 - 3.50	S10152153185127	ER 40 S	3.00 - 3.50	33	4	2.80X1.50
SEALING DISC ER 40 3.50 - 4.00	S10152153186127	ER 40 S	3.50 - 4.00	33	4	3.30X1.50
SEALING DISC ER 40 4.00 - 4.50	S10152153187127	ER 40 S	4.00 - 4.50	33	4	3.80X1.50
SEALING DISC ER 40 4.50 - 5.00	S10152153188127	ER 40 S	4.50 - 5.00	33	4	4.30X1.50
SEALING DISC ER 40 5.00 - 5.50	S10152153189127	ER 40 S	5.00 - 5.50	33	4	4.80X.1.50
SEALING DISC ER 40 5.50 - 6.00	S10152153190127	ER 40 S	5.50 - 6.00	33	4	5.30X1.50
SEALING DISC ER 40 6.00 - 6.50	S10152153191127	ER 40 S	6.00 - 6.50	33	4	5.80X1.50
SEALING DISC ER 40 6.50 - 7.00	S10152153192127	ER 40 S	6.50 - 7.00	33	4	6.30X1.50
SEALING DISC ER 40 7.00 - 7.50	S10152153193127	ER 40 S	7.00 - 7.50	33	4	6.80X1.50
SEALING DISC ER 40 7.50 - 8.00	S10152153194127	ER 40 S	7.50 - 8.00	33	4	7.30X1.50
SEALING DISC ER 40 8.00 - 8.50	S10152153195127	ER 40 S	8.00 - 8.50	33	4	7.80X1.50
SEALING DISC ER 40 8.50 - 9.00	S10152153196127	ER 40 S	8.50 - 9.00	33	4	8.30X1.50
SEALING DISC ER 40 9.00 - 9.50	S10152153197127	ER 40 S	9.00 - 9.50	33	4	8.80X1.50
SEALING DISC ER 40 9.50 - 10.00	S10152153198127	ER 40 S	9.50 - 10.00	33	4	9.30X1.50
SEALING DISC ER 40 10.00 - 10.50	S10152153199127	ER 40 S	10.00 - 10.50	33	4	9.80X1.50
SEALING DISC ER 40 10.50 - 11.00	S10152153200127	ER 40 S	10.50 - 11.00	33	4	10.30X1.50
SEALING DISC ER 40 11.00 - 11.50	S10152153201127	ER 40 S	11.00 - 11.50	33	4	10.80X1.50
SEALING DISC ER 40 11.50 - 12.00	S10152153202127	ER 40 S	11.50 - 12.00	33	4	11.30X1.50
SEALING DISC ER 40 12.00 - 12.50	S10152153203127	ER 40 S	12.00 - 12.50	33	4	11.80X1.50
SEALING DISC ER 40 12.50 - 13.00	S10152153204127	ER 40 S	12.50 - 13.00	33	4	12.30X1.50
SEALING DISC ER 40 13.00 - 13.50	S10152153305127	ER 40 S	13.00 - 13.50	33	4	12.80X1.50
SEALING DISC ER 40 13.50 - 14.00	S10152153205127	ER 40 S	13.50 - 14.00	33	4	13.30X1.50
SEALING DISC ER 40 14.00 - 14.50	S10152153206127	ER 40 S	14.00 - 14.50	33	4	13.80X1.50
SEALING DISC ER 40 14.50 - 15.00	S10152153207127	ER 40 S	14.50 - 15.00	33	4	14.30X1.50
SEALING DISC ER 40 15.00 - 15.50	S10152153208127	ER 40 S	15.00 - 15.50	33	4	14.80X1.50
SEALING DISC ER 40 15.50 - 16.00	S10152153209127	ER 40 S	15.50 - 16.00	33	4	15.30X1.50
SEALING DISC ER 40 16.00 - 16.50	S10152153210127	ER 40 S	16.00 - 16.50	33	4	15.80X1.50
SEALING DISC ER 40 16.50 - 17.00	S10152153211127	ER 40 S	16.50 - 17.00	33	4	16.30X1.50
SEALING DISC ER 40 17.00 - 17.50	S10152153212127	ER 40 S	17.00 - 17.50	33	4	16.80X1.50
SEALING DISC ER 40 17.50 - 18.00	S10152153213127	ER 40 S	17.50 - 18.00	33	4	17.30X1.50
SEALING DISC ER 40 18.00 - 18.50	S10152153214127	ER 40 S	18.00 - 18.50	33	4	17.80X1.50
SEALING DISC ER 40 18.50 - 19.00	S10152153215127	ER 40 S	18.50 - 19.00	33	4	18.30X1.50
SEALING DISC ER 40 19.00 - 19.50	S10152153216127	ER 40 S	19.00 - 19.50	33	4	18.80X1.50
SEALING DISC ER 40 19.50 - 20.00	S10152153217127	ER 40 S	19.50 - 20.00	33	4	19.30X1.50
SEALING DISC ER 40 20.00 - 20.50	S10152153218127	ER 40 S	20.00 - 20.50	33	4	19.80X1.50

Note: All Dimensions are in mm

Sealing Disc For Sealed Nut (ER-S)

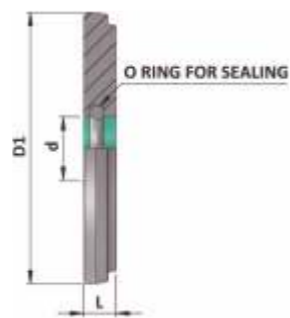

Sealing Disc ER 40

Item Name	Item Code	Suitable Nut	d	D1	L	'O' Ring Size
SEALING DISC ER 40 20.50 - 21.00	S10152153219127	ER 40 S	20.50 - 21.00	33	4	20.30X1.50
SEALING DISC ER 40 21.00 - 21.50	S10152153220127	ER 40 S	21.00 - 21.50	33	4	20.80X1.50
SEALING DISC ER 40 21.50 - 22.00	S10152153221127	ER 40 S	21.50 - 22.00	33	4	21.30X1.50
SEALING DISC ER 40 22.00 - 22.50	S10152153222127	ER 40 S	22.00 - 22.50	33	4	21.80X1.50
SEALING DISC ER 40 22.50 - 23.00	S10152153223127	ER 40 S	22.50 - 23.00	33	4	22.30X1.50
SEALING DISC ER 40 23.00 - 23.50	S10152153224127	ER 40 S	23.00 - 23.50	33	4	22.80X1.50
SEALING DISC ER 40 23.50 - 24.00	S10152153225127	ER 40 S	23.50 - 24.00	33	4	23.30X1.50
SEALING DISC ER 40 24.00 - 24.50	S10152153226127	ER 40 S	24.00 - 24.50	33	4	23.80X1.50
SEALING DISC ER 40 24.50 - 25.00	S10152153227127	ER 40 S	24.50 - 25.00	33	4	24.30X1.50
SEALING DISC ER 40 25.00 - 25.50	S10152153228127	ER 40 S	25.00 - 25.50	33	4	24.80X1.50
SEALING DISC ER 40 25.50 - 26.00	S10152153229127	ER 40 S	25.50 - 26.00	33	4	25.30X1.50

Sealing Disc ER 50

Item Name	Item Code	Suitable Nut	d	D1	L	'O' Ring Size
SEALING DISC ER 50 6.00 - 6.50	S10152154191127	ER 50 S	6.00 - 6.50	43.5	4.5	5.80X1.50
SEALING DISC ER 50 8.00 - 8.50	S10152154195127	ER 50 S	8.00 - 8.50	43.5	4.5	7.80X1.50
SEALING DISC ER 50 10.00 - 10.50	S10152154199127	ER 50 S	10.00 - 10.50	43.5	4.5	9.80X1.50
SEALING DISC ER 50 12.00 - 12.50	S10152154203127	ER 50 S	12.00 - 12.50	43.5	4.5	11.80X1.50
SEALING DISC ER 50 14.00 - 14.50	S10152154206127	ER 50 S	14.00 - 14.50	43.5	4.5	13.80X1.50
SEALING DISC ER 50 16.00 - 16.50	S10152154210127	ER 50 S	16.00 - 16.50	43.5	4.5	15.80X1.50
SEALING DISC ER 50 18.00 - 18.50	S10152154214127	ER 50 S	18.00 - 18.50	43.5	4.5	17.80X1.50
SEALING DISC ER 50 22.00 - 22.50	S10152154222127	ER 50 S	22.00 - 22.50	43.5	4.5	21.80X1.50
SEALING DISC ER 50 24.00 - 24.50	S10152154226127	ER 50 S	24.00 - 24.50	43.5	4.5	23.80X1.50
SEALING DISC ER 50 25.00 - 25.50	S10152154228127	ER 50 S	25.00 - 25.50	43.5	4.5	24.80X1.50
SEALING DISC ER 50 26.00 - 26.50	S10152154503127	ER 50 S	26.00 - 26.50	43.5	4.5	25.80X1.50
SEALING DISC ER 50 28.00 - 28.50	S10152154521127	ER 50 S	28.00 - 28.50	43.5	4.5	27.80X1.50
SEALING DISC ER 50 30.00 - 30.50	S10152154497127	ER 50 S	30.00 - 30.50	43.5	4.5	29.80X1.50
SEALING DISC ER 50 30.50 - 31.00	S10152154495127	ER 50 S	30.50 - 31.00	43.5	4.5	30.30x1.50
SEALING DISC ER 50 31.00 - 31.50	S10152154502127	ER 50 S	31.00 - 31.50	43.5	4.5	30.80X1.50
SEALING DISC ER 50 31.50 - 32.00	S10152154496127	ER 50 S	31.50 - 32.00	43.5	4.5	31.30X1.50
SEALING DISC ER 50 32.00 - 32.50	S10152154520127	ER 50 S	32.00 - 32.50	43.5	4.5	31.80X1.50

Accessories for HSK Holders

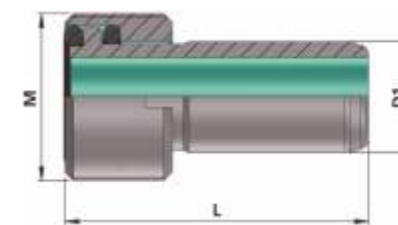

Coolant Tube For HSK-A (DIN 69893-1) Holder

Item Name	Item Code	HSK-A	D1	M	L
HSK-A 50 COOLANT TUBE	S10166232301127	50	10	M16X1	33
HSK-A 63 COOLANT TUBE	S10167232301127	63	12	M18X1	34
HSK-A 100 COOLANT TUBE	S10168232301127	100	16	M24X1.5	44

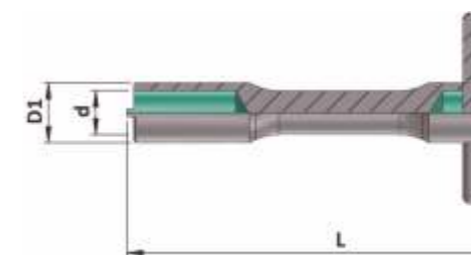

Spanner For HSK-A (DIN 69893-1) Coolant Tube

Item Name	Item Code	HSK-A	d	D1	L
HSK-A 50 COOLANT TUBE SPANNER	S10166233301127	50	10.5	14.5	90
HSK-A 63 COOLANT TUBE SPANNER	S10167233301127	63	12.2	16.5	136
HSK-A 100 COOLANT TUBE SPANNER	S10168233301127	100	16.2	22	136

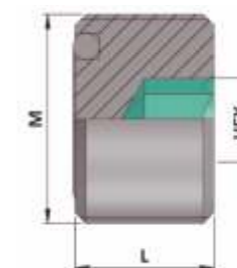

Sealing Plug For HSK-A

Item Name	Item Code	M	L	Hex
HSK-A 50 SEALING PLUG	S10166234301127	M16 X 1	10	5
HSK-A 63 SEALING PLUG	S10167234301127	M18 X 1	12	6
HSK-A 100 SEALING PLUG	S10168234301127	M24 X 1.5	16	10

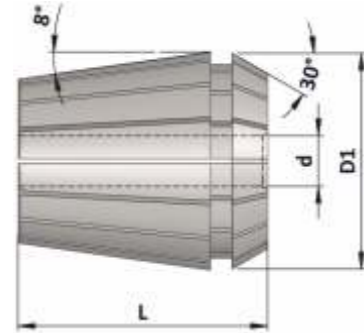

Collet ER (DIN6499) Class - 1

Item Name	Clamping Range (d)	Collet Collapse Range	D1	L	Run Out
Collet ER 11 Class-1	1 - 7	0.5 mm.	11.5	18	0.010 mm.
Collet ER 16 Class-1	1 - 10	1.0 mm.	17	27.5	0.010 mm.
Collet ER 20 Class-1	1 - 13	1.0 mm.	21	31.50	0.010 mm.
Collet ER 25 Class-1	1 - 16	1.0 mm.	26	34	0.010 mm.
Collet ER 32 Class-1	2 - 20	1.0 mm.	33	40	0.010 mm.
Collet ER 40 Class-1	3 - 26	1.0 mm.	41	46	0.010 mm.
Collet ER 50 Class-1	10 - 34	2.0 mm.	52	60	0.010 mm.

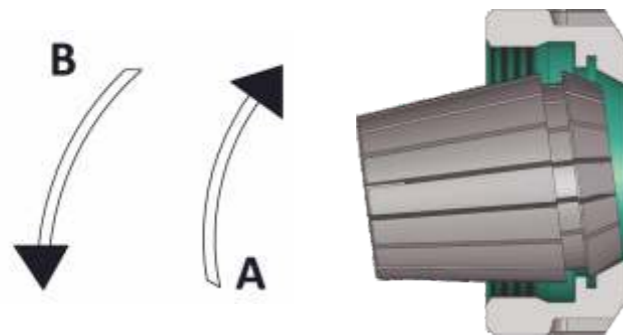

ER Collet & Nut Operating Method :

- The Collet must always be inserted into the nut before setting the tool into the collet.
- The collet is fitted inside the nut by applying slight pressure **A**.
- It is removed by applying Pressure **B** to the collet.
- Never tighten the chuck without a correct size tool shank being present in the collet.



Collet Set ER (DIN 6499)

Item Name	Item Code	Clamping Range	PCS / SET
COLLET SET ER 11 (1 - 7 MM) 7 PIECES CLASS I	S10264148493207	1 - 7	7
COLLET SET ER 16 (1-10 MM) 10 PCS WITH BOX CLASS I	S10264149484207	1 - 10	10
COLLET SET ER 20 (2-13 MM)12 PCS WITH BOX CLASS I	S10264150535207	2 - 13	12
COLLET SET ER 25 (2- 16 MM) 15PCS WITH BOX CLASS I	S10264151514207	2 - 16	15
COLLET SET ER 32 (3-20 MM) 18 PCS WITH BOX CLASS I	S10264152485207	3 - 20	18
COLLET SET ER 40 (3-26 MM) 24 PCS WITH BOX CLASS I	S10264153494207	3 - 26	24

Collet ER (DIN 6499)

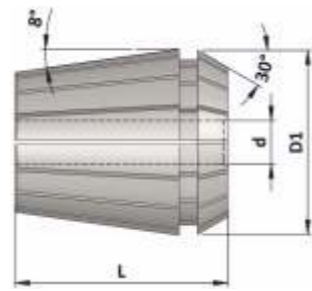

Collet ER 11 (Class-1)

Item Name	Item Code	Clamping Range (d)	D1	L
COLLET ER11 DIA 1.0 - 0.5 - CLASS I	S10154329301207	1.0 - 0.50	11.5	18
COLLET ER11 DIA 2.0 - 1.5 - CLASS I	S10154331301207	2.0 - 1.5	11.5	18
COLLET ER11 DIA 3.0 - 2.5 - CLASS I	S10154333301207	3.0 - 2.5	11.5	18
COLLET ER11 DIA 4.0 - 3.5 - CLASS I	S10154335301207	4.0 - 3.5	11.5	18
COLLET ER11 DIA 5.0 - 4.5 - CLASS I	S10154337301207	5.0 - 4.5	11.5	18
COLLET ER11 DIA 6.0 - 5.5 - CLASS I	S10154339301207	6.0 - 5.5	11.5	18
COLLET ER11 DIA 7.0 - 6.5 - CLASS I	S10154343301207	7.0 - 6.5	11.5	18

Collet ER 16 (Class-1)

COLLET ER16 DIA 1.0 - 0.5 - CLASS I	S10155291301207	1.0 - 0.50	17	27.5
COLLET ER16 DIA 2.0 - 1.0 - CLASS I	S10155292301207	2.0 - 1.0	17	27.5
COLLET ER16 DIA 3.0 - 2.0 - CLASS I	S10155293301207	3.0 - 2.0	17	27.5
COLLET ER16 DIA 4.0 - 3.0 - CLASS I	S10155294301207	4.0 - 3.0	17	27.5
COLLET ER16 DIA 5.0 - 4.0 - CLASS I	S10155295301207	5.0 - 4.0	17	27.5
COLLET ER16 DIA 6.0 - 5.0 - CLASS I	S10155296301207	6.0 - 5.0	17	27.5
COLLET ER16 DIA 7.0 - 6.0 - CLASS I	S10155297301207	7.0 - 6.0	17	27.5
COLLET ER16 DIA 8.0 - 7.0 - CLASS I	S10155298301207	8.0 - 7.0	17	27.5
COLLET ER16 DIA 9.0 - 8.0 - CLASS I	S10155299301207	9.0 - 8.0	17	27.5
COLLET ER16 DIA 10.0 - 9.0 - CLASS I	S10155300301207	10.0 - 9.0	17	27.5

Collet ER 20 (Class-1)

COLLET ER20 DIA 1.0 - 0.50 - CLASS I	S10156329301207	1 - 0.50	21	31.5
COLLET ER20 DIA 2 - 1 - CLASS I	S10156292301207	2 - 1	21	31.5
COLLET ER20 DIA 3 - 2 - CLASS I	S10156293301207	3 - 2	21	31.5
COLLET ER20 DIA 4 - 3 - CLASS I	S10156294301207	4 - 3	21	31.5
COLLET ER20 DIA 5 - 4 - CLASS I	S10156295301207	5 - 4	21	31.5
COLLET ER20 DIA 6 - 5 - CLASS I	S10156296301207	6 - 5	21	31.5
COLLET ER20 DIA 7 - 6 - CLASS I	S10156297301207	7 - 6	21	31.5
COLLET ER20 DIA 8 - 7 - CLASS I	S10156298301207	8 - 7	21	31.5
COLLET ER20 DIA 9 - 8 - CLASS I	S10156299301207	9 - 8	21	31.5
COLLET ER20 DIA 10 - 9 - CLASS I	S10156300301207	10 - 9	21	31.5
COLLET ER20 DIA 11 - 10 - CLASS I	S10156301301207	11 - 10	21	31.5
COLLET ER20 DIA 12 - 11 - CLASS I	S10156302301207	12 - 11	21	31.5
COLLET ER20 DIA 13 - 12 - CLASS I	S10156303301207	13 - 12	21	31.5

Collet ER (DIN 6499)

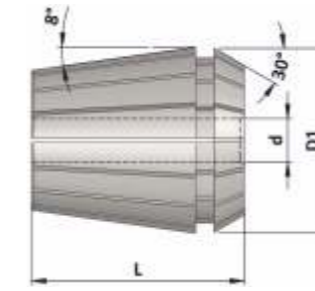

Collet ER 25 (Class-1)

Item Name	Item Code	Clamping Range (d)	D1	L
COLLET ER25 DIA 1.0 - 0.50 - CLASS I	S10157329301207	1.0 - 0.50	26	34
COLLET ER25 DIA 2 - 1 - CLASS I	S10157292301207	2 - 1	26	34
COLLET ER25 DIA 3 - 2 - CLASS I	S10157293301207	3 - 2	26	34
COLLET ER25 DIA 4 - 3 - CLASS I	S10157294301207	4 - 3	26	34
COLLET ER25 DIA 5 - 4 - CLASS I	S10157295301207	5 - 4	26	34
COLLET ER25 DIA 6 - 5 - CLASS I	S10157296301207	6 - 5	26	34
COLLET ER25 DIA 7 - 6 - CLASS I	S10157297301207	7 - 6	26	34
COLLET ER25 DIA 8 - 7 - CLASS I	S10157298301207	8 - 7	26	34
COLLET ER25 DIA 9 - 8 - CLASS I	S10157299301207	9 - 8	26	34
COLLET ER25 DIA 10 - 9 - CLASS I	S10157300301207	10 - 9	26	34
COLLET ER25 DIA 11 - 10 - CLASS I	S10157301301207	11 - 10	26	34
COLLET ER25 DIA 12 - 11 - CLASS I	S10157302301207	12 - 11	26	34
COLLET ER25 DIA 13 - 12 - CLASS I	S10157303301207	13 - 12	26	34
COLLET ER25 DIA 14 - 13 - CLASS I	S10157304301207	14 - 13	26	34
COLLET ER25 DIA 15 - 14 - CLASS I	S10157305301207	15 - 14	26	34
COLLET ER25 DIA 16 - 15 - CLASS I	S10157306301207	16 - 15	26	34

Collet ER 32 (Class-1)

COLLET ER32 DIA 1.0 - 0.50 - CLASS I	S10158291301207	1.0 - 0.50	33	40
COLLET ER32 DIA 2 - 1 - CLASS I	S10158292301207	2 - 1	33	40
COLLET ER32 DIA 3 - 2 - CLASS I	S10158293301207	3 - 2	33	40
COLLET ER32 DIA 4 - 3 - CLASS I	S10158294301207	4 - 3	33	40
COLLET ER32 DIA 5 - 4 - CLASS I	S10158295301207	5 - 4	33	40
COLLET ER32 DIA 6 - 5 - CLASS I	S10158296301207	6 - 5	33	40
COLLET ER32 DIA 7 - 6 - CLASS I	S10158297301207	7 - 6	33	40
COLLET ER32 DIA 8 - 7 - CLASS I	S10158298301207	8 - 7	33	40
COLLET ER32 DIA 9 - 8 - CLASS I	S10158299301207	9 - 8	33	40
COLLET ER32 DIA 10 - 9 - CLASS I	S10158300301207	10 - 9	33	40
COLLET ER32 DIA 11 - 10 - CLASS I	S10158301301207	11 - 10	33	40
COLLET ER32 DIA 12 - 11 - CLASS I	S10158302301207	12 - 11	33	40
COLLET ER32 DIA 13 - 12 - CLASS I	S10158303301207	13 - 12	33	40
COLLET ER32 DIA 14 - 13 - CLASS I	S10158304301207	14 - 13	33	40
COLLET ER32 DIA 15 - 14 - CLASS I	S10158305301207	15 - 14	33	40
COLLET ER32 DIA 16 - 15 - CLASS I	S10158306301207	16 - 15	33	40
COLLET ER32 DIA 17 - 16 - CLASS I	S10158307301207	17 - 16	33	40
COLLET ER32 DIA 18 - 17 - CLASS I	S10158308301207	18 - 17	33	40
COLLET ER32 DIA 19 - 18 - CLASS I	S10158309301207	19 - 18	33	40
COLLET ER32 DIA 20 - 19 - CLASS I	S10158310301207	20 - 19	33	40

Collet ER 40 (Class-1)

Item Name	Item Code	Clamping Range (d)	D1	L
COLLET ER40 DIA 3 - 2 - CLASS I	S10159293301207	3 - 2	41	46
COLLET ER40 DIA 4 - 3 - CLASS I	S10159294301207	4 - 3	41	46
COLLET ER40 DIA 5 - 4 - CLASS I	S10159295301207	5 - 4	41	46
COLLET ER40 DIA 6 - 5 - CLASS I	S10159296301207	6 - 5	41	46
COLLET ER40 DIA 7 - 6 - CLASS I	S10159297301207	7 - 6	41	46
COLLET ER40 DIA 8 - 7 - CLASS I	S10159298301207	8 - 7	41	46
COLLET ER40 DIA 9 - 8 - CLASS I	S10159299301207	9 - 8	41	46
COLLET ER40 DIA 10 - 9 - CLASS I	S10159300301207	10 - 9	41	46
COLLET ER40 DIA 11 - 10 - CLASS I	S10159301301207	11 - 10	41	46
COLLET ER40 DIA 12 - 11 - CLASS I	S10159302301207	12 - 11	41	46
COLLET ER40 DIA 13 - 12 - CLASS I	S10159303301207	13 - 12	41	46
COLLET ER40 DIA 14 - 13 - CLASS I	S10159304301207	14 - 13	41	46
COLLET ER40 DIA 15 - 14 - CLASS I	S10159305301207	15 - 14	41	46
COLLET ER40 DIA 16 - 15 - CLASS I	S10159306301207	16 - 15	41	46
COLLET ER40 DIA 17 - 16 - CLASS I	S10159307301207	17 - 16	41	46
COLLET ER40 DIA 18 - 17 - CLASS I	S10159308301207	18 - 17	41	46
COLLET ER40 DIA 19 - 18 - CLASS I	S10159309301207	19 - 18	41	46
COLLET ER40 DIA 20 - 19 - CLASS I	S10159310301207	20 - 19	41	46
COLLET ER40 DIA 21 - 20 - CLASS I	S10159311301207	21 - 20	41	46
COLLET ER40 DIA 22 - 21 - CLASS I	S10159312301207	22 - 21	41	46
COLLET ER40 DIA 23 - 22 - CLASS I	S10159313301207	23 - 22	41	46
COLLET ER40 DIA 24 - 23 - CLASS I	S10159314301207	24 - 23	41	46
COLLET ER40 DIA 25 - 24 - CLASS I	S10159315301207	25 - 24	41	46
COLLET ER40 DIA 26 - 25 - CLASS I	S10159316301207	26 - 25	41	46

Collet ER 50 (Class-1)

COLLET ER50 DIA 4 - 3 - CLASS I	S10196495301207	4 - 3	52	60
COLLET ER50 DIA 6 - 5 - CLASS I	S10196494301207	6 - 5	52	60
COLLET ER50 DIA 10 - 9 - CLASS I	S10196493301207	10 - 9	52	60
COLLET ER50 DIA 12 - 10 - CLASS I	S10196317301207	12 - 10	52	60
COLLET ER50 DIA 14 - 12 - CLASS I	S10196318301207	14 - 12	52	60
COLLET ER50 DIA 16 - 14 - CLASS I	S10196319301207	16 - 14	52	60
COLLET ER50 DIA 18 - 16 - CLASS I	S10196320301207	18 - 16	52	60
COLLET ER50 DIA 20 - 18 - CLASS I	S10196321301207	20 - 18	52	60
COLLET ER50 DIA 22 - 20 - CLASS I	S10196322301207	22 - 20	52	60
COLLET ER50 DIA 24 - 22 - CLASS I	S10196323301207	24 - 22	52	60
COLLET ER50 DIA 26 - 24 - CLASS I	S10196324301207	26 - 24	52	60
COLLET ER50 DIA 28 - 26 - CLASS I	S10196325301207	28 - 26	52	60
COLLET ER50 DIA 30 - 28 - CLASS I	S10196326301207	30 - 28	52	60
COLLET ER50 DIA 32 - 30 - CLASS I	S10196327301207	32 - 30	52	60
COLLET ER50 DIA 34 - 32 - CLASS I	S10196328301207	34 - 32	52	60

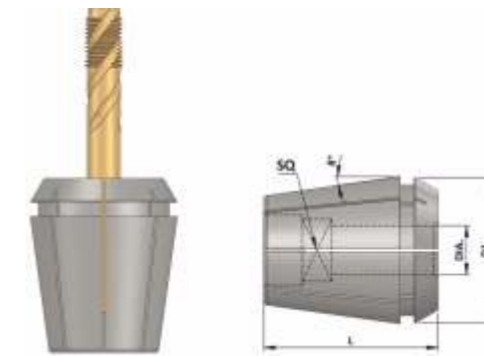

Tap Collet ER 16 G

Item Name	Item Code	Dia	Square	D1	L
TAP COLLET ER 16G 3.5 X 2.7	S10255479449127	3.50	2.70	17	27.5
TAP COLLET ER 16G 4.0 X 3.0	S10255479450127	4.00	3.00	17	27.5
TAP COLLET ER 16G 4.0 X 3.15	S10255479565127	4.00	3.15	17	27.5
TAP COLLET ER 16G 4.5 X 3.4	S10255479451127	4.50	3.40	17	27.5
TAP COLLET ER 16G 5.0 X 4.0	S10255479452127	5.00	4.00	17	27.5
TAP COLLET ER 16G 5.5 X 4.3	S10255479557127	5.50	4.30	17	27.5
TAP COLLET ER 16G 6.0 X 4.9	S10255479453127	6.00	4.90	17	27.5
TAP COLLET ER 16G 6.3 X 5.0	S10255479454127	6.30	5.00	17	27.5
TAP COLLET ER 16G 7.0 X 5.5	S10255479455127	7.00	5.50	17	27.5
TAP COLLET ER 16G 7.1 X 5.6	S10255479570127	7.10	5.60	17	27.5
TAP COLLET ER 16G 8.0 X 6.2	S10255479456127	8.00	6.20	17	27.5
TAP COLLET ER 16G 8.0 X 6.3	S10255479456225	8.00	6.30	17	27.5
TAP COLLET ER 16G 9.0 X 7.0	S10255479457127	9.00	7.00	17	27.5
TAP COLLET ER 16G 9.0 X 7.1	S10255479474127	9.00	7.10	17	27.5
TAP COLLET ER 16G 10.0 X 8.0	S10255479458127	10.00	8.00	17	27.5

Tap Collet ER 20 G

TAP COLLET ER 20G 3.5 X 2.7	S10255480449127	3.50	2.70	21	31.5
TAP COLLET ER 20G 4.0 X 3.0	S10255480450127	4.00	3.00	21	31.5
TAP COLLET ER 20G 4.0 X 3.15	S10255480565127	4.00	3.15	21	31.5
TAP COLLET ER 20G 4.5 X 3.4	S10255480451127	4.50	3.40	21	31.5
TAP COLLET ER 20G 5.0 X 4.0	S10255480452127	5.00	4.00	21	31.5
TAP COLLET ER 20G 5.5 X 4.3	S10255480557127	5.50	4.30	21	31.5
TAP COLLET ER 20G 6.0 X 4.9	S10255480453127	6.00	4.90	21	31.5
TAP COLLET ER 20G 6.3 X 5.0	S10255480454127	6.30	5.00	21	31.5
TAP COLLET ER 20G 7.0 X 5.5	S10255480455127	7.00	5.50	21	31.5
TAP COLLET ER 20G 7.1 X 5.6	S10255480570127	7.10	5.60	21	31.5
TAP COLLET ER 20G 8.0 X 6.2	S10255480456127	8.00	6.20	21	31.5
TAP COLLET ER 20G 8.0 X 6.3	S10255480456225	8.00	6.30	21	31.5
TAP COLLET ER 20G 9.0 X 7.0	S10255480457127	9.00	7.00	21	31.5
TAP COLLET ER 20G 9.0 X 7.1	S10255480474127	9.00	7.10	21	31.5
TAP COLLET ER 20G 10.0 X 8.0	S10255480458127	10.00	8.00	21	31.5
TAP COLLET ER 20G 11.0 X 9.0	S10255480469127	11.00	9.00	21	31.5
TAP COLLET ER 20G 11.2 X 9.0	S10255480459127	11.20	9.00	21	31.5
TAP COLLET ER 20G 12.0 X 9.0	S10255480460127	12.00	9.00	21	31.5

Tap Collet ER G

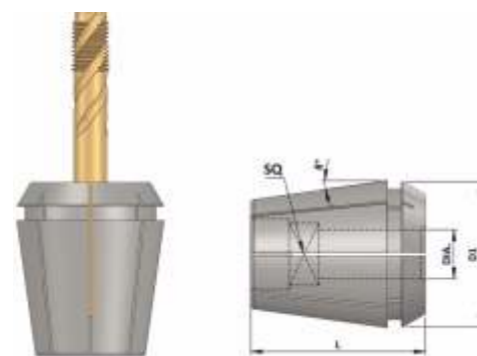

Tap Collet ER 25 G

Item Name	Item Code	Dia	Square	D1	L
TAP COLLET ER 25G 3.5 X 2.7	S10255151449127	3.50	2.70	26	34
TAP COLLET ER 25G 4.0 X 3.0	S10255481450127	4.00	3.00	26	34
TAP COLLET ER 25G 4.0 X 3.15	S10255481565127	4.00	3.15	26	34
TAP COLLET ER 25G 4.5 X 3.4	S10255481451127	4.50	3.40	26	34
TAP COLLET ER 25G 5.0 X 4.0	S10255481452127	5.00	4.00	26	34
TAP COLLET ER 25G 5.5 X 4.3	S10255481557127	5.50	4.30	26	34
TAP COLLET ER 25G 6.0 X 4.9	S10255481453127	6.00	4.90	26	34
TAP COLLET ER 25G 6.3 X 5.0	S10255481454127	6.30	5.00	26	34
TAP COLLET ER 25G 7.0 X 5.5	S10255481455127	7.00	5.50	26	34
TAP COLLET ER 25G 7.1 X 5.6	S10255481570127	7.10	5.60	26	34
TAP COLLET ER 25G 8.0 X 6.2	S10255481456127	8.00	6.20	26	34
TAP COLLET ER 25G 8.0 X 6.3	S10255481195127	8.00	6.30	26	34
TAP COLLET ER 25G 9.0 X 7.0	S10255481457127	9.00	7.00	26	34
TAP COLLET ER 25G 9.0 X 7.1	S10255481474127	9.00	7.10	26	34
TAP COLLET ER 25G 10.0 X 8.0	S10255481458127	10.00	8.00	26	34
TAP COLLET ER 25G 11.0 X 9.0	S10255481469127	11.00	9.00	26	34
TAP COLLET ER 25G 11.2 X 9.0	S10255481459127	11.20	9.00	26	34
TAP COLLET ER 25G 12.0 X 9.0	S10255481460127	12.00	9.00	26	34
TAP COLLET ER 25G 12.5 X 10.0	S10255481461127	12.50	10.00	26	34
TAP COLLET ER 25G 14.0 X 11.0	S10255481462127	14.00	11.00	26	34
TAP COLLET ER 25G 14.0 X 11.2	S10255481463127	14.00	11.20	26	34
TAP COLLET ER 25G 16.0 X 12.0	S10255481470127	16.00	12.00	26	34

Tap Collet ER 32 G

TAP COLLET ER 32G 3.5 X 2.7	S10255482449127	3.50	2.70	33	40
TAP COLLET ER 32G 4.0 X 3.0	S10102173256127	4.00	3.00	33	40
TAP COLLET ER 32G 4.0 X 3.15	S10255482565127	4.00	3.15	33	40
TAP COLLET ER 32G 4.5 X 3.4	S10255482451127	4.50	3.40	33	40
TAP COLLET ER 32G 5.0 X 4.0	S10255482452127	5.00	4.00	33	40
TAP COLLET ER 32G 5.5 X 4.3	S10255482557127	5.50	4.30	33	40
TAP COLLET ER 32G 6.0 X 4.9	S10255482453127	6.00	4.90	33	40
TAP COLLET ER 32G 6.3 X 5.0	S10255482454127	6.30	5.00	33	40
TAP COLLET ER 32G 7.0 X 5.5	S10255482455127	7.00	5.50	33	40
TAP COLLET ER 32G 7.1 X 5.6	S10255482570127	7.10	5.60	33	40
TAP COLLET ER 32G 8.0 X 6.2	S10255482456127	8.00	6.20	33	40

Tap Collet ER G

Tap Collet ER 32 G

Item Name	Item Code	Dia	Square	D1	L
TAP COLLET ER 32G 8.0 X 6.3	S10255482564127	8.00	6.30	33	40
TAP COLLET ER 32G 9.0 X 7.0	S10255482457127	9.00	7.00	33	40
TAP COLLET ER 32G 9.0 X 7.1	S10255482474127	9.00	7.10	33	40
TAP COLLET ER 32G 10.0 X 8.0	S10255482458127	10.00	8.00	33	40
TAP COLLET ER 32G 11.0 X 9.0	S10255482469127	11.00	9.00	33	40
TAP COLLET ER 32G 11.2 X 9.0	S10255482459127	11.20	9.00	33	40
TAP COLLET ER 32G 12.0 X 9.0	S10255482460127	12.00	9.00	33	40
TAP COLLET ER 32G 12.5 X 10.0	S10255482461127	12.50	10.00	33	40
TAP COLLET ER 32G 14.0 X 11.0	S10255482462127	14.00	11.00	33	40
TAP COLLET ER 32G 14.0 X 11.2	S10255482463127	14.00	11.20	33	40
TAP COLLET ER 32G 16.0 X 12.0	S10255482470127	16.00	12.00	33	40
TAP COLLET ER 32G 16.0 X 12.5	S10255482464127	16.00	12.50	33	40
TAP COLLET ER 32G 18.0 X 14.0	S10255152558127	18.00	14.00	33	40
TAP COLLET ER 32G 18.0 X 14.5	S10255482465127	18.00	14.50	33	40
TAP COLLET ER 32G 20.0 X 16.0	S10255482466127	20.00	16.00	33	40

Tap Collet ER 40 G

TAP COLLET ER 40G 3.5 X 2.7	S 10255153449127	3.50	2.70	41	46
TAP COLLET ER 40G 4.0 X 3.0	S 10255483450127	4.00	3.00	41	46
TAP COLLET ER 40G 4.5 X 3.4	S 10255153451127	4.50	3.40	41	46
TAP COLLET ER 40G 6.0 X 4.9	S 10255483453127	6.00	4.90	41	46
TAP COLLET ER 40G 6.3 X 5.0	S 10255483454127	6.30	5.00	41	46
TAP COLLET ER 40G 7.0 X 5.5	S 10255483455127	7.00	5.50	41	46
TAP COLLET ER 40G 7.1 X 5.6	S 10255483570127	7.10	5.60	41	46
TAP COLLET ER 40G 8.0 X 6.2	S 10255483456127	8.00	6.20	41	46
TAP COLLET ER 40G 8.0 X 6.3	S 10255483456207	8.00	6.30	41	46
TAP COLLET ER 40G 9.0 X 7.0	S 10255483457127	9.00	7.00	41	46
TAP COLLET ER 40G 9.0 X 7.1	S 10255483474127	9.00	7.10	41	46
TAP COLLET ER 40G 10.0 X 8.0	S 10255483458127	10.00	8.00	41	46
TAP COLLET ER 40G 11.0 X 9.0	S 10255483469127	11.00	9.00	41	46
TAP COLLET ER 40G 11.2 X 9.0	S 10255483459127	11.20	9.00	41	46
TAP COLLET ER 40G 12.0 X 9.0	S 10255483460127	12.00	9.00	41	46
TAP COLLET ER 40G 12.5 X 10.0	S 10255483461127	12.50	10.00	41	46
TAP COLLET ER 40G 14.0 X 11.0	S 10255483462127	14.00	11.00	41	46
TAP COLLET ER 40G 14.0 X 11.2	S 10255483463127	14.00	11.20	41	46
TAP COLLET ER 40G 16.0 X 12.0	S 10255483470127	16.00	12.00	41	46
TAP COLLET ER 40G 16.0 X 12.5	S 10255483464127	16.00	12.50	41	46
TAP COLLET ER 40G 18.0 X 14.0	S 10255153558127	18.00	14.00	41	46
TAP COLLET ER 40G 18.0 X 14.5	S 10255483465127	18.00	14.50	41	46
TAP COLLET ER 40G 20.0 X 16.0	S 10255483466127	20.00	16.00	41	46
TAP COLLET ER 40G 22.0 X 18.0	S 10255483467127	22.00	18.00	41	46
TAP COLLET ER 40G 22.4 X 18.0	S 10255483575127	22.40	18.00	41	46
TAP COLLET ER 40G 25.0 X 20.0	S 10255483468127	25.00	20.00	41	46

Collet DMC

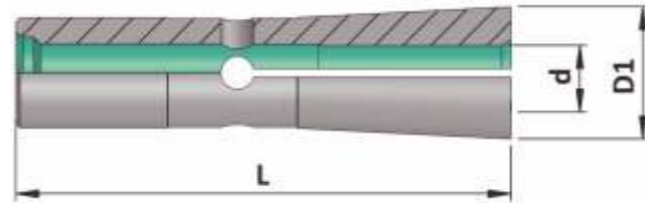

Collet DMC

(Concentricity within 0.005 mm)

Item Name	Item Code	d	D1	L
COLLET DMC06 02	S10108199301127	2	9.6	36
COLLET DMC06 03	S10108200301127	3	9.6	36
COLLET DMC06 04	S10108201301127	4	9.6	36
COLLET DMC06 05	S10108202301127	5	9.6	36
COLLET DMC06 06	S10108203301127	6	9.6	36
COLLET DMC08 03	S10109200301127	3	15	45
COLLET DMC08 04	S10109201301127	4	15	45
COLLET DMC08 06	S10109203301127	6	15	45
COLLET DMC08 08	S10109205301127	8	15	45
COLLET DMC10 04	S10110201301127	4	19.1	52
COLLET DMC10 06	S10110203301127	6	19.1	52
COLLET DMC10 08	S10110205301127	8	19.1	52
COLLET DMC10 10	S10110207301127	10	19.1	52

Reduction Sleeve (RS) For Power Milling Chuck & Hyd. Chuck

SIGMA
TOOLINGS

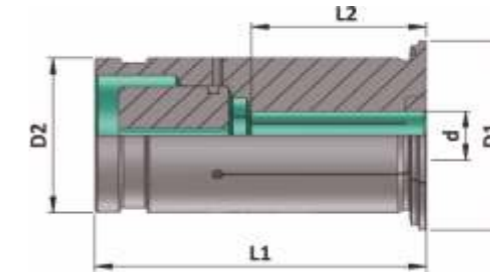

Reduction Sleeve (RS)

(Concentricity within 0.005 mm)

Item Name	Item Code	d	D1	D2	L1	L2
RS 12 X 3	S10310182301127	3	16.50	12	48	14
RS 12 X 4	S10310183301127	4	16.50	12	48	15
RS 12 X 5	S10310184301127	5	16.50	12	48	18
RS 12 X 6	S10310185301127	6	16.50	12	48	25
RS 12 X 8	S10310187301127	8	16.50	12	48	26
RS 20 X 3	S10106182301127	3	29	20	52.5	14
RS 20 X 4	S10106183301127	4	29	20	52.5	15
RS 20 X 5	S10106184301127	5	29	20	52.5	18
RS 20 X 6	S10106185301127	6	29	20	52.5	25
RS 20 X 7	S10106186301127	7	29	20	52.5	25
RS 20 X 8	S10106187301127	8	29	20	52.5	30
RS 20 X 9	S10106188301127	9	29	20	52.5	30
RS 20 X10	S10106189301127	10	29	20	52.5	33
RS 20 X11	S10106190301127	11	29	20	52.5	33
RS 20 X12	S10106191301127	12	29	20	52.5	34
RS 20 X13	S10106192301127	13	29	20	52.5	34
RS 20 X14	S10106193301127	14	29	20	52.5	34
RS 20 X15	S10106194301127	15	29	20	52.5	40
RS 20 X16	S10106195301127	16	29	20	52.5	40
RS 32 X 6	S10107185301127	6	39	32	63.5	25
RS 32 X 8	S10107187301127	8	39	32	63.5	25
RS 32 X10	S10107189301127	10	39	32	63.5	33
RS 32 X12	S10107191301127	12	39	32	63.5	34
RS 32 X14	S10107193301127	14	39	32	63.5	34
RS 32 X16	S10107195301127	16	39	32	63.5	40
RS 32 X18	S10107271301127	18	39	32	63.5	40
RS 32 X20	S10107196301127	20	39	32	63.5	40
RS 32 X25	S10107197301127	25	39	32	63.5	42

Quick Change Tap Collet ER Type (Rigid) (QCTC-ER)



Quick Change Tap Collet ER Type (Rigid) (QCTC-ER) Technical Information

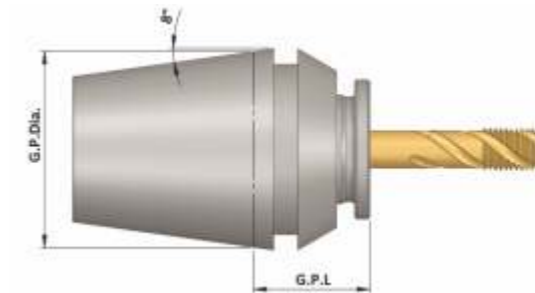

Technical Information

Item Name	G.P. Dia	G. P. L.	Tap Holding Range Dia. x Sq.		Tapping Range
			Min.	Max.	
QCTC -ER16	16.00	14.00	Ø3.15 x 2.50 SQ.	Ø6.30 x 5.00 SQ.	M3 TO M8
QCTC -ER20	20.00	15.50	Ø3.15 x 2.50 SQ.	Ø7.10 x 5.60 SQ.	M3 TO M10
QCTC -ER25	25.00	16.00	Ø3.15 x 2.50 SQ.	Ø10.00 x 8.00 SQ.	M3 TO M12
QCTC -ER32	32.00	20.00	Ø3.15 x 2.50 SQ.	Ø14.00 x 11.20 SQ.	M3 TO M20
QCTC -ER40	40.00	22.00	Ø3.15 x 2.50 SQ.	Ø18.00 x 14.50 SQ.	M3 TO M24

◆ Features :

- This System is to be used along with “ER” Collect Chuck on CNC & spm’s for Rigid Tapping Operation.
- No Compression & No Expansion.
- Use External Coolant Supply.
- Rigid Clamping & Quick Replace of Tap.
- Tap Collet Selection According to the ER type & the Diameter & Square of the Tap.

Quick Change Tap Collet ER Type (Rigid) (QCTC-ER)

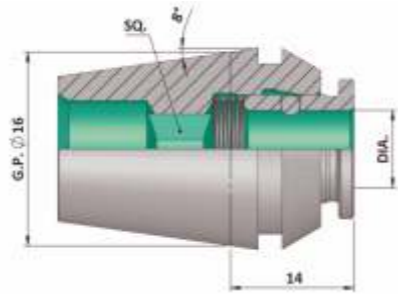

QCTC ER 16

As per (ISO) (529 -1975) Standards

Item Name	Item Code	Dia	Square
QCTC ER 16 3.15 X 2.50	S11259304297	3.15	2.50
QCTC ER 16 3.55 X 2.80	S11259304298	3.55	2.80
QCTC ER 16 4.0 X 3.15	S11259304300	4.00	3.15
QCTC ER 16 4.50 X 3.55	S11259304299	4.50	3.55
QCTC ER 16 5.0 X 4.0	S11259304301	5.00	4.00
QCTC ER 16 5.60 X 4.50	S11259304302	5.60	4.50
QCTC ER 16 6.3 X 5.0	S11259304291	6.30	5.00

As per (DIN) Standards

QCTC ER 16 3.5 X 2.7	S11259304276	3.50	2.70
QCTC ER 16 4.0 X 3.0	S11259304277	4.00	3.00
QCTC ER 16 4.5 X 3.4	S11259304278	4.50	3.40
QCTC ER 16 6.0 X 4.9	S11259304279	6.00	4.90

As per (JIS) Standards

QCTC ER 16 4.0 X 3.0	S11259304277	4.00	3.00
QCTC ER 16 4.0 X 3.20	S11259304306	4.00	3.20
QCTC ER 16 5.0 X 4.0	S11259304301	5.00	4.00
QCTC ER 16 5.5 X 4.5	S11259238307	5.50	4.50
QCTC ER 16 6.0 X 4.50	S11259304308	6.00	4.50
QCTC ER 16 6.10 X 5.0	S11259304309	6.10	5.00
QCTC ER 16 6.20 X 5.0	S11259304310	6.20	5.00

Note: All Dimensions are in mm
For DIN Standard Numbers and more technical details please see page number 212-215

Quick Change Tap Collet ER Type (Rigid) (QCTC-ER)

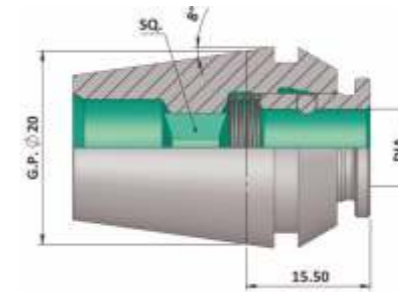

QCTC ER 20

As per (ISO) (529 -1975) Standards

Item Name	Item Code	Dia	Square
QCTC ER 20 3.15 X 2.50	S11259305297	3.15	2.50
QCTC ER 20 3.55 X 2.80	S11259305298	3.55	2.80
QCTC ER 20 4.0 X 3.15	S11259305300	4.00	3.15
QCTC ER 20 4.50 X 3.55	S11259305299	4.50	3.55
QCTC ER 20 5.0 X 4.0	S11259305301	5.00	4.00
QCTC ER 20 5.60 X 4.50	S11259305302	5.60	4.50
QCTC ER 20 6.3 X 5.0	S11259305291	6.30	5.00
QCTC ER 20 7.10 X 5.60	S11259305292	7.10	5.60

As per (DIN) Standards

QCTC ER 20 3.5 X 2.7	S11259305276	3.50	2.70
QCTC ER 20 4.0 X 3.0	S11259305277	4.00	3.00
QCTC ER 20 4.5 X 3.4	S11259305278	4.50	3.40
QCTC ER 20 6.0 X 4.9	S11259305279	6.00	4.90
QCTC ER 20 7.0 X 5.5	S11259305280	7.00	5.50

As per (JIS) Standards

QCTC ER 20 4.0 X 3.0	S11259305277	4.00	3.00
QCTC ER 20 4.0 X 3.20	S11259305306	4.00	3.20
QCTC ER 20 5.0 X 4.0	S11259305301	5.00	4.00
QCTC ER 20 5.50 X 4.50	S11259305307	5.50	4.50
QCTC ER 20 6.0 X 4.50	S11259305308	6.00	4.50
QCTC ER 20 6.10 X 5.0	S11259305309	6.10	5.00
QCTC ER 20 6.20 X 5.0	S11259305310	6.20	5.00
QCTC ER 20 7.0 X 5.5	S11259305280	7.00	5.50

Note: All Dimensions are in mm
For DIN Standard Numbers and more technical details please see page number 212-215

**Quick Change Tap Collet ER Type (Rigid)
(QCTC-ER)**

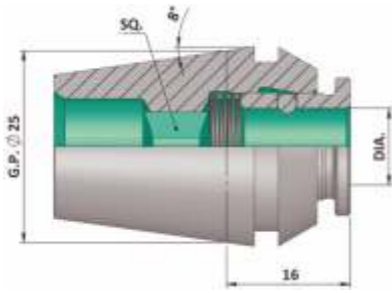

QCTC ER 25

As per (ISO) (529 -1975) Standards

Item Name	Item Code	Dia	Square
QCTC ER 25 3.15 X 2.50	S11259306297	3.15	2.50
QCTC ER 25 3.55 X 2.80	S11259306298	3.55	2.80
QCTC ER 25 4.0 X 3.15	S11259306300	4.00	3.15
QCTC ER 25 4.50 X 3.55	S11259306299	4.50	3.55
QCTC ER 25 5.0 X 4.0	S11259306301	5.00	4.00
QCTC ER 25 5.60 X 4.50	S11259306302	5.60	4.50
QCTC ER 25 6.3 X 5.0	S11259306291	6.30	5.00
QCTC ER 25 7.1 X 5.6	S11259306292	7.10	5.60
QCTC ER 25 8.0 X 6.30	S11259306303	8.00	6.30
QCTC ER 25 9.0 X 7.10	S11259306304	9.00	7.10
QCTC ER 25 10.0 X 8.0	S11259306283	10.00	8.00

As per (DIN) Standards

QCTC ER 25 3.5 X 2.7	S11259306276	3.50	2.70
QCTC ER 25 4.0 X 3.0	S11259306277	4.00	3.00
QCTC ER 25 4.5 X 3.4	S11259306278	4.50	3.40
QCTC ER 25 6.0 X 4.9	S11259306279	6.00	4.90
QCTC ER 25 7.0 X 5.5	S11259306280	7.00	5.50
QCTC ER 25 8.0 X 6.2	S11259306281	8.00	6.20
QCTC ER 25 9.0 X 7.0	S11259306282	9.00	7.00
QCTC ER 25 10.0 X 8.0	S11259306283	10.00	8.00

As per (JIS) Standards

QCTC ER 25 4.0 X 3.0	S11259306277	4.00	3.00
QCTC ER 25 4.0 X 3.20	S11259306306	4.00	3.20
QCTC ER 25 5.0 X 4.0	S11259306301	5.00	4.00
QCTC ER 25 5.50 X 4.50	S11259306307	5.50	4.50
QCTC ER 25 6.0 X 4.50	S11259306308	6.00	4.50
QCTC ER 25 6.10 X 5.0	S11259306309	6.10	5.00
QCTC ER 25 6.20 X 5.0	S11259306310	6.20	5.00
QCTC ER 25 7.0 X 5.5	S11259306280	7.00	5.50
QCTC ER 25 8.0 X 6.0	S11259306311	8.00	6.00
QCTC ER 25 8.0 X 6.2	S11259306281	8.00	6.20
QCTC ER 25 8.50 X 6.50	S11259306312	8.50	6.50
QCTC ER 25 9.0 X 7.0	S11259306282	9.00	7.00

Note: All Dimensions are in mm
For DIN Standard Numbers and more technical details please see page number 212-215

**Quick Change Tap Collet ER Type (Rigid)
(QCTC-ER)**

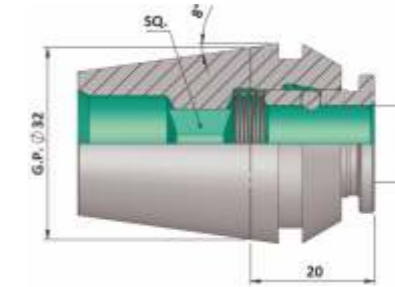

QCTC ER 32

As per (ISO) (529 -1975) Standards

Item Name	Item Code	Dia	Square
QCTC ER 32 3.15 X 2.50	S11259307297	3.15	2.50
QCTC ER 32 3.55 X 2.80	S11259307298	3.55	2.80
QCTC ER 32 4.0 X 3.15	S11259307300	4.00	3.15
QCTC ER 32 4.50 X 3.55	S11259307299	4.50	3.55
QCTC ER 32 5.0 X 4.0	S11259307301	5.00	4.00
QCTC ER 32 5.60 X 4.50	S11259307302	5.60	4.50
QCTC ER 32 6.3 X 5.0	S11259307291	6.30	5.00
QCTC ER 32 7.1 X 5.60	S11259307292	7.10	5.60
QCTC ER 32 8.0 X 6.30	S11259307303	8.00	6.30
QCTC ER 32 9.0 X 7.10	S11259307304	9.00	7.10
QCTC ER 32 10.0 X 8.0	S11259307283	10.00	8.00
QCTC ER 32 11.2 X 9.0	S11259307293	11.20	9.00
QCTC ER 32 12.5 X 10.0	S11259307294	12.50	10.00
QCTC ER 32 14.0 X 11.20	S11259307305	14.00	11.20

As per (DIN) Standards

QCTC ER 32 3.5 X 2.7	S11259307276	3.50	2.70
QCTC ER 32 4.0 X 3.0	S11259307277	4.00	3.00
QCTC ER 32 4.5 X 3.4	S11259307278	4.50	3.40
QCTC ER 32 6.0 X 4.9	S11259307279	6.00	4.90
QCTC ER 32 7.0 X 5.5	S11259307280	7.00	5.50
QCTC ER 32 8.0 X 6.2	S11259307281	8.00	6.20
QCTC ER 32 9.0 X 7.0	S11259307287	9.00	7.00
QCTC ER 32 10.0 X 8.0	S11259307283	10.00	8.00
QCTC ER 32 11.0 X 9.0	S11259307284	11.00	9.00
QCTC ER 32 12.0 X 9.0	S11259307285	12.00	9.00
QCTC ER 32 14.0 X 11.0	S11259307286	14.00	11.00

Note: All Dimensions are in mm
For DIN Standard Numbers and more technical details please see page number 212-215

Quick Change Tap Collet ER Type (Rigid) (QCTC-ER)

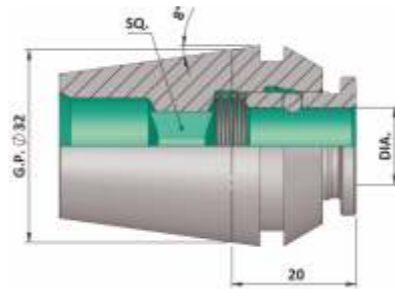

QCTC ER 32

As per (JIS) Standards

Item Name	Item Code	Dia	Square
QCTC ER 32 4.0 X 3.0	S11259307277	4.00	3.00
QCTC ER 32 4.0 X 3.20	S11259307306	4.00	3.20
QCTC ER 32 5.0 X 4.0	S11259307301	5.00	4.00
QCTC ER 32 5.50 X 4.50	S11259307307	5.50	4.50
QCTC ER 32 6.0 X 4.50	S11259307308	6.00	4.50
QCTC ER 32 6.10 X 5.0	S11259307309	6.10	5.00
QCTC ER 32 6.20 X 5.0	S11259307310	6.20	5.00
QCTC ER 32 7.0 X 5.5	S11259307280	7.00	5.50
QCTC ER 32 8.0 X 6.0	S11259307311	8.00	6.00
QCTC ER 32 8.0 X 6.2	S11259307281	8.00	6.20
QCTC ER 32 8.50 X 6.50	S11259307312	8.50	6.50
QCTC ER 32 9.0 X 7.0	S11259307287	9.00	7.00
QCTC ER 32 10.50 X 8.0	S11259307313	10.50	8.00
QCTC ER 32 11.0 X 9.0	S11259307284	11.00	9.00
QCTC ER 32 12.0 X 9.0	S11259307285	12.00	9.00
QCTC ER 32 12.5 X 10.0	S11259307294	12.50	10.00
QCTC ER 32 14.0 X 11.0	S11259307286	14.00	11.00

Note: All Dimensions are in mm
For DIN Standard Numbers and more technical details please see page number 212-215

Quick Change Tap Collet ER Type (Rigid) (QCTC-ER)

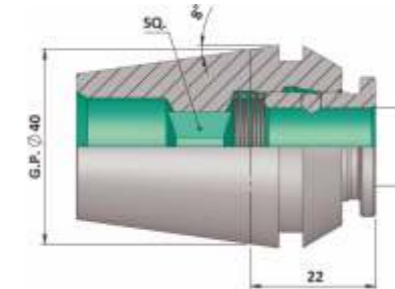

QCTC ER 40

As per (ISO) (529 -1975) Standards

Item Name	Item Code	Dia	Square
QCTC ER 40 3.15 X 2.50	S11259308297	3.15	2.50
QCTC ER 40 3.55 X 2.80	S11259308298	3.55	2.80
QCTC ER 40 4.0 X 3.15	S11259308300	4.00	3.15
QCTC ER 40 4.50 X 3.55	S11259308299	4.50	3.55
QCTC ER 40 5.0 X 4.0	S11259308301	5.00	4.00
QCTC ER 40 5.60 X 4.50	S11259308302	5.60	4.50
QCTC ER 40 6.3 X 5.0	S11259308291	6.30	5.00
QCTC ER 40 7.10 X 5.60	S11259308292	7.10	5.60
QCTC ER 40 8.0 X 6.30	S11259308303	8.00	6.30
QCTC ER 40 9.0 X 7.10	S11259308304	9.00	7.10
QCTC ER 40 10.0 X 8.0	S11259308283	10.00	8.00
QCTC ER 40 11.2 X 9.0	S11259308293	11.20	9.00
QCTC ER 40 12.5 X 10.0	S11259308294	12.50	10.00
QCTC ER 40 14.0 X 11.20	S11259308286	14.00	11.20
QCTC ER 40 16.0 X 12.5	S11259308295	16.00	12.50
QCTC ER 40 18.0 X 14.0	S11259308289	18.00	14.00

As per (DIN) Standards

QCTC ER 40 3.5 X 2.7	S11259308276	3.50	2.70
QCTC ER 40 4.0 X 3.0	S11259308277	4.00	3.00
QCTC ER 40 4.5 X 3.4	S11259308278	4.50	3.40
QCTC ER 40 6.0 X 4.9	S11259308279	6.00	4.90
QCTC ER 40 7.0 X 5.5	S11259308280	7.00	5.50
QCTC ER 40 8.0 X 6.2	S11259308281	8.00	6.20
QCTC ER 40 9.0 X 7.0	S11259308282	9.00	7.00
QCTC ER 40 10.0 X 8.0	S11259308283	10.00	8.00
QCTC ER 40 11.0 X 9.0	S11259308284	11.00	9.00
QCTC ER 40 12.0 X 9.0	S11259308285	12.00	9.00
QCTC ER 40 14.0 X 11.0	S11259240286	14.00	11.00
QCTC ER 40 16.0 X 12.0	S11259308288	16.00	12.00
QCTC ER 40 18.0 X 14.5	S11259308296	18.00	14.50

Note: All Dimensions are in mm
For DIN Standard Numbers and more technical details please see page number 212-215

Quick Change Tap Collet ER Type (Rigid) (QCTC-ER)

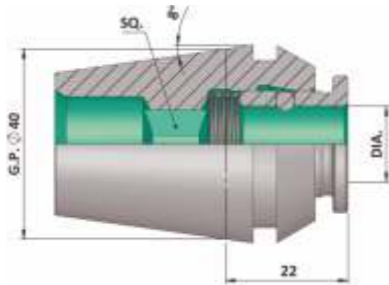

QCTC ER 40

As per (JIS) Standards

Item Name	Item Code	Dia	Square
QCTC ER 40 4.0 X 3.0	S11259308277	4.00	3.00
QCTC ER 40 4.0 X 3.20	S11259308306	4.00	3.20
QCTC ER 40 5.0 X 4.0	S11259308301	5.00	4.00
QCTC ER 40 5.50 X 4.50	S11259308307	5.50	4.50
QCTC ER 40 6.0 X 4.50	S11259308308	6.00	4.50
QCTC ER 40 6.10 X 5.0	S11259308309	6.10	5.00
QCTC ER 40 6.20 X 5.0	S11259308310	6.20	5.00
QCTC ER 40 7.0 X 5.5	S11259308280	7.00	5.50
QCTC ER 40 8.0 X 6.0	S11259308311	8.00	6.00
QCTC ER 40 8.0 X 6.2	S11259308281	8.00	6.20
QCTC ER 40 8.50 X 6.50	S11259308312	8.50	6.50
QCTC ER 40 9.0 X 7.0	S11259308282	9.00	7.00
QCTC ER 40 10.50 X 8.0	S11259308313	10.50	8.00
QCTC ER 40 11.0 X 9.0	S11259308284	11.00	9.00
QCTC ER 40 12.0 X 9.0	S11259308285	12.00	9.00
QCTC ER 40 12.5 X 10.0	S11259308294	12.50	10.00
QCTC ER 40 13.0 X 10.0	S11259308314	13.00	10.00
QCTC ER 40 14.0 X 11.0	S11259240286	14.00	11.00
QCTC ER 40 15.0 X 12.0	S11259308315	15.00	12.00
QCTC ER 40 16.0 X 12.0	S11259308288	16.00	12.00
QCTC ER 40 18.0 X 14.0	S11259308289	18.00	14.00

Note: All Dimensions are in mm
For DIN Standard Numbers and more technical details please see page number 212-215

Quick Change Tap Adaptor Without Safety Clutch (KWE)

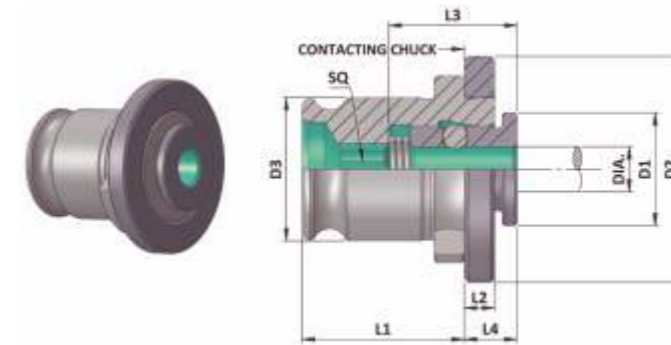

Technical Information

Item Name	Capacity	Shank Dia.	Suitable Chuck Size	D1	D2	D3	L1	L2	L3	L4
KWE 0	M1 - M10	2.5 - 8.0	0	13	22	13	19.5	4	15	7
KWE 1	M3 - M12	3.5 - 11.2	1	19	30	19	21.5	4	17	7
KWE 2	M8 - M20	6 - 18	2	30	48	31	35	5	30	11

Note: All Dimensions are in mm

**Quick Change Tap Adaptor (KWE..)
(Without Safety Clutch)**

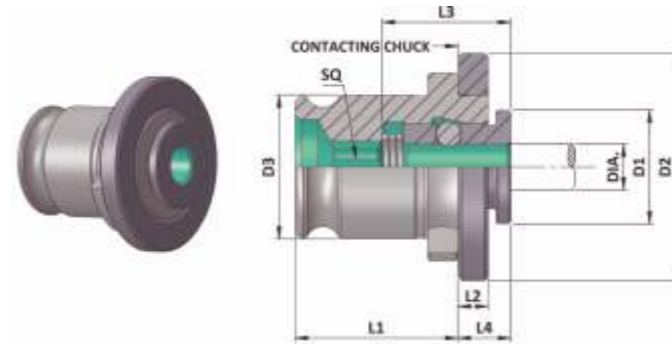

KWEO Tap Adaptor

Item Name	Capacity	Shank Dia.	Suitable Chuck Size	D1	D2	D3	L1	L2	L3	L4
KWE 0	M1 - M10	2.5 - 8.0	0	13	22	13	19.5	4	15	7

As per (ISO) (529 -1975) Standards

Item Name	Item Code	Dia	Square
KWEO DIA 3.15 SQ 2.50	S11128118193	3.15	2.50
KWEO DIA 3.55 SQ 2.80	S11128119193	3.55	2.80
KWEO DIA 4.00 SQ 3.15	S11128120193	4.00	3.15
KWEO DIA 4.50 SQ 3.55	S11128121193	4.50	3.55
KWEO DIA 5.00 SQ 4.00	S11128122193	5.00	4.00
KWEO DIA 5.60 SQ 4.50	S11128123193	5.60	4.50
KWEO DIA 6.30 SQ 5.00	S11128124193	6.30	5.00
KWEO DIA 7.10 SQ 5.60	S11128125193	7.10	5.60
KWEO DIA 8.00 SQ 6.30	S11128126193	8.00	6.30

As per (DIN) Standards

KWEO DIA 2.50 SQ 2.10	S11128141193	2.50	2.10
KWEO DIA 2.80 SQ 2.10	S11128142193	2.80	2.10
KWEO DIA 3.50 SQ 2.70	S11128143193	3.50	2.70
KWEO DIA 4.00 SQ 3.00	S11128144193	4.00	3.00
KWEO DIA 4.50 SQ 3.40	S11128145193	4.50	3.40
KWEO DIA 6.00 SQ 4.90	S11128146193	6.00	4.90
KWEO DIA 7.00 SQ 5.50	S11128147193	7.00	5.50
KWEO DIA 8.00 SQ 6.20	S11128148193	8.00	6.20

Continued...

Note: All Dimensions are in mm
For DIN Standard Numbers and more technical details please see page number 212-215

**Quick Change Tap Adaptor (KWE..)
(Without Safety Clutch)**

As per (JIS) Standards

Item Name	Item Code	Dia	Square
KWEO DIA 3.00 SQ 2.50	S11128162193	3.00	2.50
KWEO DIA 4.00 SQ 3.00	S11128144193	4.00	3.00
KWEO DIA 4.00 SQ 3.20	S11128163193	4.00	3.20
KWEO DIA 5.00 SQ 4.00	S11128122193	5.00	4.00
KWEO DIA 5.50 SQ 4.50	S11128164193	5.50	4.50
KWEO DIA 6.00 SQ 4.50	S11128165193	6.00	4.50
KWEO DIA 6.10 SQ 5.00	S11128166193	6.10	5.00
KWEO DIA 6.20 SQ 5.00	S11128167193	6.20	5.00
KWEO DIA 7.00 SQ 5.50	S11128147193	7.00	5.50
KWEO DIA 8.00 SQ 6.00	S11128168193	8.00	6.00
KWEO DIA 8.00 SQ 6.20	S11128148193	8.00	6.20

As per (ANSI) (US) Standards

KWEO DIA 0.141" SQ 0.110"	S11128191193	0.141"	0.110"
KWEO DIA 0.168" SQ 0.131"	S11128192193	0.168"	0.131"
KWEO DIA 0.194" SQ 0.152"	S11128198193	0.194"	0.152"
KWEO DIA 0.220" SQ 0.165"	S11128199193	0.220"	0.165"
KWEO DIA 0.255" SQ 0.191"	S11128200193	0.255"	0.191"

Note: All Dimensions are in mm
For DIN Standard Numbers and more technical details please see page number 212-215

**Quick Change Tap Adaptor (KWE..)
(Without Safety Clutch)**

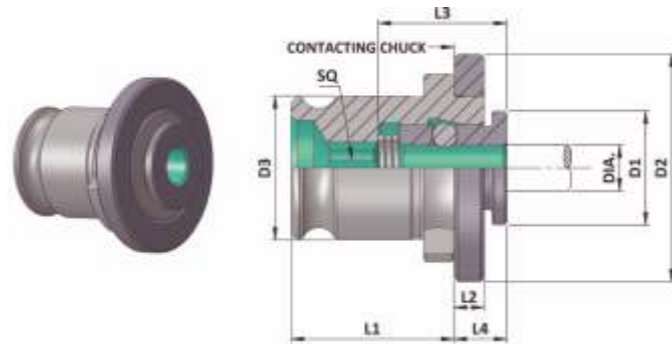

KWE1 Tap Adaptor

Item Name	Capacity	Shank Dia.	Suitable Chuck Size	D1	D2	D3	L1	L2	L3	L4
KWE 1	M3 - M12	3.5 - 11.2	1	19	30	19	21.5	4	17	7

As per (ISO) (529 -1975) Standards

Item Name	Item Code	Dia	Square
KWE1 DIA 3.15 SQ 2.50	S11129118193	3.15	2.50
KWE1 DIA 3.55 SQ 2.80	S11129119193	3.55	2.80
KWE1 DIA 4.00 SQ 3.15	S11129120193	4.00	3.15
KWE1 DIA 4.50 SQ 3.55	S11129121193	4.50	3.55
KWE1 DIA 5.00 SQ 4.00	S11129122193	5.00	4.00
KWE1 DIA 5.60 SQ 4.50	S11129123193	5.60	4.50
KWE1 DIA 6.30 SQ 5.00	S11129124193	6.30	5.00
KWE1 DIA 7.10 SQ 5.60	S11129125193	7.10	5.60
KWE1 DIA 8.00 SQ 6.30	S11129126193	8.00	6.30
KWE1 DIA 9.00 SQ 7.10	S11129127193	9.00	7.10
KWE1 DIA 10.00 SQ 8.00	S11129128193	10.00	8.00
KWE1 DIA 11.20 SQ 9.00	S11129129193	11.20	9.00

As per (DIN) Standards

KWE1 DIA 2.50 SQ 2.10	S11129141193	2.50	2.10
KWE1 DIA 2.80 SQ 2.10	S11129142193	2.80	2.10
KWE1 DIA 3.50 SQ 2.70	S11129143193	3.50	2.70
KWE1 DIA 4.00 SQ 3.00	S11129144193	4.00	3.00
KWE1 DIA 4.50 SQ 3.40	S11129145193	4.50	3.40
KWE1 DIA 6.00 SQ 4.90	S11129146193	6.00	4.90
KWE1 DIA 7.00 SQ 5.50	S11129147193	7.00	5.50
KWE1 DIA 8.00 SQ 6.20	S11129148193	8.00	6.20
KWE1 DIA 9.00 SQ 7.00	S11129149193	9.00	7.00
KWE1 DIA 10.00 SQ 8.00	S11129128193	10.00	8.00
KWE1 DIA 11.00 SQ 9.00	S11129150193	11.00	9.00

Continued...

Note: All Dimensions are in mm
For DIN Standard Numbers and more technical details please see page number 212-215

**Quick Change Tap Adaptor (KWE..)
(Without Safety Clutch)**

As per (JIS) Standards

Item Name	Item Code	Dia	Square
KWE1 DIA 3.00 SQ 2.50	S11129162193	3.00	2.50
KWE1 DIA 4.00 SQ 3.00	S11129144193	4.00	3.00
KWE1 DIA 4.00 SQ 3.20	S11129163193	4.00	3.20
KWE1 DIA 5.00 SQ 4.00	S11129122193	5.00	4.00
KWE1 DIA 5.50 SQ 4.50	S11129164193	5.50	4.50
KWE1 DIA 6.00 SQ 4.50	S11129165193	6.00	4.50
KWE1 DIA 6.10 SQ 5.00	S11129166193	6.10	5.00
KWE1 DIA 6.20 SQ 5.00	S11129167193	6.20	5.00
KWE1 DIA 7.00 SQ 5.50	S11129147193	7.00	5.50
KWE1 DIA 8.00 SQ 6.00	S11129168193	8.00	6.00
KWE1 DIA 8.00 SQ 6.20	S11129148193	8.00	6.20
KWE1 DIA 8.50 SQ 6.50	S11129170193	8.50	6.50
KWE1 DIA 9.00 SQ 7.00	S11129149193	9.00	7.00
KWE1 DIA 9.50 SQ 7.00	S11129171193	9.50	7.00
KWE1 DIA 10.50 SQ 8.00	S11129172193	10.50	8.00
KWE1 DIA 11.00 SQ 9.00	S11129150193	11.00	9.00

As per (ANSI) (US) Standards

KWE1 DIA 0.141" SQ 0.110"	S11129191193	0.141"	0.110"
KWE1 DIA 0.141" SQ 0.110" TC	S11129191249	0.141"	0.110"
KWE1 DIA 0.168" SQ 0.131"	S11129192193	0.168"	0.131"
KWE1 DIA 0.168" SQ 0.131" TC	S11129192249	0.168"	0.131"
KWE1 DIA 0.194" SQ 0.152"	S11129198193	0.194"	0.152"
KWE1 DIA 0.194" SQ 0.152" NO-10 TC	S11236198193	0.194"	0.152"
KWE1 DIA 0.220" SQ 0.165"	S11129199193	0.220"	0.165"
KWE1 DIA 0.220" SQ 0.165" TC	S11129199249	0.220"	0.165"
KWE1 DIA 0.255" SQ 0.191"	S11129200193	0.255"	0.191"
KWE1 DIA 0.255" SQ 0.191" 1/4" TC	S11236200193	0.255"	0.191"
KWE1 DIA 0.313" SQ 0.234"	S11129201193	0.313"	0.234"
KWE1 DIA 0.318" SQ 0.238" 5/16" TC	S11236202193	0.318"	0.238"
KWE1 DIA 0.318" SQ 0.238"	S11129202193	0.318"	0.238"
KWE1 DIA 0.323" SQ 0.242"	S11129193193	0.323"	0.242"
KWE1 DIA 0.323" SQ 0.242" TC	S11129193249	0.323"	0.242"
KWE1 DIA 0.367" SQ 0.275"	S11129194193	0.367"	0.275"
KWE1 DIA 0.367" SQ 0.275" TC	S11129194249	0.367"	0.275"
KWE1 DIA 0.381" SQ 0.286"	S11129195193	0.381"	0.286"
KWE1 DIA 0.381" SQ 0.286" 3/8" TC	S11236195193	0.381"	0.286"
KWE1 DIA 0.429" SQ 0.322"	S11129196193	0.429"	0.322"
KWE1 DIA 0.429" SQ 0.322" TC	S11129196249	0.429"	0.322"
KWE1 DIA 0.437" SQ 0.328"	S11129197193	0.437"	0.328"
KWE1 DIA 0.437" SQ 0.328" TC	S11129197249	0.437"	0.328"

Note: All Dimensions are in mm
For DIN Standard Numbers and more technical details please see page number 212-215

**Quick Change Tap Adaptor (KWE..)
(Without Safety Clutch)**

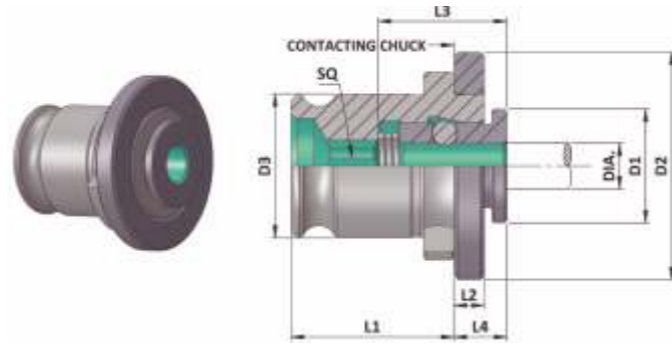

Technical Information

Item Name	Capacity	Shank Dia.	Suitable Chuck Size	D1	D2	D3	L1	L2	L3	L4
KWE 2	M8 - M20	6 - 18	2	30	48	31	35	5	30	11

As per (ISO) (529 -1975) Standards

Item Name	Item Code	Dia	Square
KWE2 DIA 6.30 SQ 5.00	S11130124193	6.30	5.00
KWE2 DIA 7.10 SQ 5.60	S11130125193	7.10	5.60
KWE2 DIA 8.00 SQ 6.30	S11130126193	8.00	6.30
KWE2 DIA 9.00 SQ 7.10	S11130127193	9.00	7.10
KWE2 DIA 10.00 SQ 8.00	S11130128193	10.00	8.00
KWE2 DIA 11.20 SQ 9.00	S11130129193	11.20	9.00
KWE2 DIA 12.50 SQ 10.00	S11130130193	12.50	10.00
KWE2 DIA 14.00 SQ 11.20	S11130131193	14.00	11.20
KWE2 DIA 16.00 SQ 12.50	S11130132193	16.00	12.50
KWE2 DIA 18.00 SQ 14.00	S11130133193	18.00	14.00

As per (DIN) Standards

KWE2 DIA 6.00 SQ 4.90	S11130146193	6.00	4.90
KWE2 DIA 7.00 SQ 5.50	S11130147193	7.00	5.50
KWE2 DIA 8.00 SQ 6.20	S11130148193	8.00	6.20
KWE2 DIA 9.00 SQ 7.00	S11130149193	9.00	7.00
KWE2 DIA 10.00 SQ 8.00	S11130128193	10.00	8.00
KWE2 DIA 11.00 SQ 9.00	S11130150193	11.00	9.00
KWE2 DIA 12.00 SQ 9.00	S11130151193	12.00	9.00
KWE2 DIA 14.00 SQ 11.00	S11130152193	14.00	11.00
KWE2 DIA 16.00 SQ 12.00	S11130153193	16.00	12.00
KWE2 DIA 18.00 SQ 14.50	S11130154193	18.00	14.50

Continued...

Note: All Dimensions are in mm
For DIN Standard Numbers and more technical details please see page number 212-215

**Quick Change Tap Adaptor (KWE..)
(Without Safety Clutch)**

As per (JIS) Standards

Item Name	Item Code	Dia	Square
KWE2 DIA 6.00 SQ 4.50	S11130165193	6.00	4.50
KWE2 DIA 6.10 SQ 5.00	S11130166193	6.10	5.00
KWE2 DIA 6.20 SQ 5.00	S11130167193	6.20	5.00
KWE2 DIA 7.00 SQ 5.50	S11130147193	7.00	5.50
KWE2 DIA 8.00 SQ 6.00	S11130168193	8.00	6.00
KWE2 DIA 8.00 SQ 6.20	S11130148193	8.00	6.20
KWE2 DIA 8.50 SQ 6.50	S11130170193	8.50	6.50
KWE2 DIA 9.00 SQ 7.00	S11130149193	9.00	7.00
KWE2 DIA 9.50 SQ 7.00	S11130171193	9.50	7.00
KWE2 DIA 10.50 SQ 8.00	S11130172193	10.50	8.00
KWE2 DIA 11.00 SQ 9.00	S11130150193	11.00	9.00
KWE2 DIA 12.00 SQ 9.00	S11130151193	12.00	9.00
KWE2 DIA 12.50 SQ 10.00	S11130130193	12.50	10.00
KWE2 DIA 13.00 SQ 10.00	S11130173193	13.00	10.00
KWE2 DIA 14.00 SQ 11.00	S11130152193	14.00	11.00
KWE2 DIA 15.00 SQ 12.00	S11130174193	15.00	12.00
KWE2 DIA 16.00 SQ 12.00	S11130153193	16.00	12.00
KWE2 DIA 17.00 SQ 13.00	S11130175193	17.00	13.00
KWE2 DIA 18.00 SQ 14.00	S11130133193	18.00	14.00

Note: All Dimensions are in mm
For DIN Standard Numbers and more technical details please see page number 212-215

**Quick Change Tap Adaptor (KWE..)
(Without Safety Clutch)**

As per (ANSI) (US) Standards

Item Name	Item Code	Dia	Square
KWE2 DIA 0.141" SQ 0.110"	S 11130191193	0.141"	0.110"
KWE2 DIA 0.168" SQ 0.131"	S 11130192193	0.168"	0.131"
KWE2 DIA 0.194" SQ 0.152"	S 11130198193	0.194"	0.152"
KWE2 DIA 0.220" SQ 0.165"	S 11130199193	0.220"	0.165"
KWE2 DIA 0.255" SQ 0.191"	S 11130200193	0.255"	0.191"
KWE2 DIA 0.313" SQ 0.234"	S 11130201193	0.313"	0.234"
KWE2 DIA 0.318" SQ 0.238"	S 11130202193	0.318"	0.238"
KWE2 DIA 0.318" SQ 0.238" 5/16" TC	S 11234202193	0.318"	0.238"
KWE2 DIA 0.323" SQ 0.242"	S 11130193193	0.323"	0.242"
KWE2 DIA 0.323" SQ 0.242" 7/16" TC	S 11234193193	0.323"	0.242"
KWE2 DIA 0.367" SQ 0.275"	S 11130194193	0.367"	0.275"
KWE2 DIA 0.367" SQ 0.275" 1/2" TC	S 11234194193	0.367"	0.275"
KWE2 DIA 0.381" SQ 0.286"	S 11130195193	0.381"	0.286"
KWE2 DIA 0.381" SQ 0.286" 3/8" TC	S 11234195234	0.381"	0.286"
KWE2 DIA 0.429" SQ 0.322"	S 11130196193	0.429"	0.322"
KWE2 DIA 0.429" SQ 0.322" TC	S 11130196249	0.429"	0.322"
KWE2 DIA 0.437" SQ 0.328"	S 11130197193	0.437"	0.328"
KWE2 DIA 0.480" SQ 0.360"	S 11130203193	0.480"	0.360"
KWE2 DIA 0.480" SQ 0.360" 5/8" TC	S 11234203193	0.480"	0.360"
KWE2 DIA 0.542" SQ 0.406"	S 11130204193	0.542"	0.406"
KWE2 DIA 0.542" SQ 0.406" TC	S 11130204249	0.542"	0.406"
KWE2 DIA 0.562" SQ 0.421"	S 11130205193	0.562"	0.421"
KWE2 DIA 0.562" SQ 0.421" TC	S 11130205249	0.562"	0.421"
KWE2 DIA 0.590" SQ 0.442"	S 11130206193	0.590"	0.442"
KWE2 DIA 0.590" SQ 0.442" 3/4" TC	S 11234206235	0.590"	0.442"
KWE2 DIA 0.652" SQ 0.489"	S 11130207193	0.652"	0.489"
KWE2 DIA 0.652" SQ 0.489" TC	S 11130207249	0.652"	0.489"
KWE2 DIA 0.687" SQ 0.515"	S 11130208193	0.687"	0.515"
KWE2 DIA 0.687" SQ 0.515" 1/2" P TC	S 11234208173	0.687"	0.515"
KWE2 DIA 0.697" SQ 0.523"	S 11130209193	0.697"	0.523"
KWE2 DIA 0.697" SQ 0.523" TC	S 11130209249	0.697"	0.523"
KWE2 DIA 0.700" SQ 0.531"	S 11130210193	0.700"	0.531"
KWE2 DIA 0.700" SQ 0.531" TC	S 11130210249	0.700"	0.531"

Note: All Dimensions are in mm
For DIN Standard Numbers and more technical details please see page number 212-215

**Quick Change Tap Adaptor
With Safety Clutch (KWES../B)**

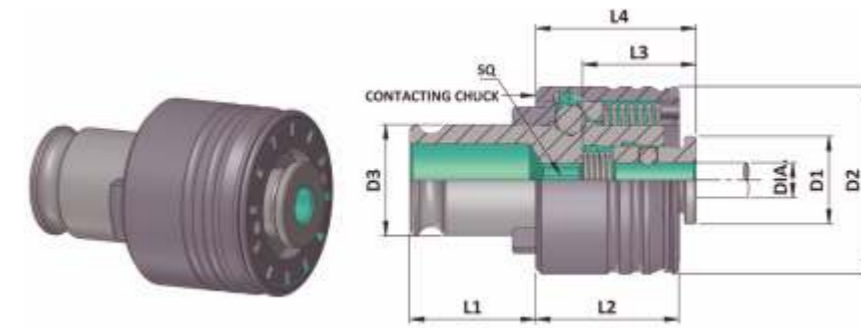

Technical Information

Item Name	Capacity	Shank Dia.	Suitable Chuck Size	D1	D2	D3	L1	L2	L3	L4
KWES 0 B	M1 - M10	2.5 - 8.0	0	13	23	13	19.5	20	15	21
KWES 1 B	M3 - M12	3.5 - 11.2	1	19	32	19	21.5	25	17	25
KWES 2 B	M8 - M20	6 - 18	2	30	50	31	35	31	30	34
KWES 3 B	M14 - M33	11 - 28	3	48	72	48	55.5	41	44	45
KWES 4 B	M22 - M48	18 - 36	4	60	95	60	63	61	71	68

Application :

- Quick Change Tap Adaptor KWES../B are used along with Sigma Quick Change Tapping Chuc on CNC Lathe, CNC Milling & Manual Lathe & Drilling Machines.

Features :

- Taps can be changed quickly without additional tooling Support. Different Adaptor is required for each tap, depends on Tap shank dia & square size.
- Safety cluth protects tap breakages. Blind holes tapping becomes easy.

Note: All Dimensions are in mm

**Quick Change Tap Adaptor (KWES../B)
(With Safety Clutch)**

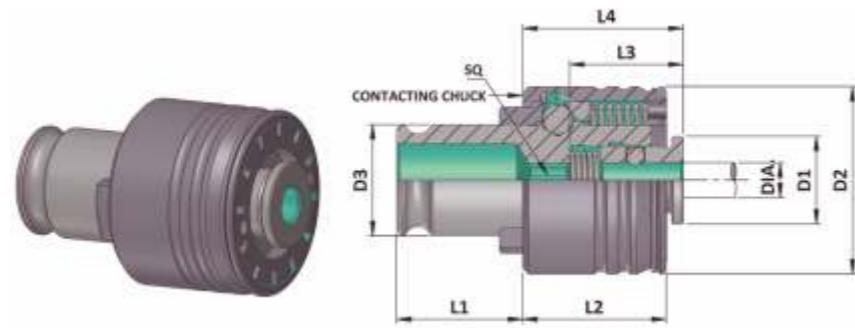

KWESOB Tap Adaptor

Item Name	Capacity	Shank Dia.	Suitable Chuck Size	D1	D2	D3	L1	L2	L3	L4
KWES 0 B	M1 - M10	2.5 - 8.0	0	13	23	13	19.5	20	15	21

As per (ISO) (529 -1975) Standards

Item Name	Item Code	Dia	Square
KWESOB DIA 3.15 SQ 2.50 M3	S11132118104	3.15	2.50
KWESOB DIA 3.15 SQ 2.50 M4	S11132118105	3.15	2.50
KWESOB DIA 3.55 SQ 2.80 M3.5	S11132119106	3.55	2.80
KWESOB DIA 3.55 SQ 2.80 M4.5	S11132119107	3.55	2.80
KWESOB DIA 4.00 SQ 3.15 M4	S11132120105	4.00	3.15
KWESOB DIA 4.00 SQ 3.15 M5	S11132120108	4.00	3.15
KWESOB DIA 4.50 SQ 3.55 M6	S11132121109	4.50	3.55
KWESOB DIA 5.00 SQ 4.00 M5	S11132122108	5.00	4.00
KWESOB DIA 5.60 SQ 4.50 M7	S11132123110	5.60	4.50
KWESOB DIA 6.30 SQ 5.00 M6	S11132124109	6.30	5.00
KWESOB DIA 6.30 SQ 5.00 M8	S11132124111	6.30	5.00
KWESOB DIA 7.10 SQ 5.60 M10	S11132125112	7.10	5.60
KWESOB DIA 8.00 SQ 6.30 M8	S11132126111	8.00	6.30
KWESOB DIA 8.00 SQ 6.30 M10	S11132126112	8.00	6.30
KWESOB DIA 3.15 SQ 2.50 NO. 04UNC	S11132118188	3.15	2.50
KWESOB DIA 3.15 SQ 2.50 NO. 05UNC	S11132118189	3.15	2.50
KWESOB DIA 3.15 SQ 2.50 NO. 08UNC	S11132118156	3.15	2.50
KWESOB DIA 3.55 SQ 2.80 3/16" UNC	S11132119196	3.55	2.80
KWESOB DIA 3.55 SQ 2.80 NO. 06UNC	S11132119155	3.55	2.80
KWESOB DIA 3.55 SQ 2.80 NO. 10UNC	S11132119157	3.55	2.80
KWESOB DIA 4.00 SQ 3.15 7/32" UNC	S11132120197	4.00	3.15
KWESOB DIA 4.00 SQ 3.15 NO. 12UNC	S11132120158	4.00	3.15
KWESOB DIA 4.50 SQ 3.55 1/4" UNC	S11132121159	4.50	3.55
KWESOB DIA 4.50 SQ 3.55 NO. 08UNC	S11132121156	4.50	3.55
KWESOB DIA 5.00 SQ 4.00 3/16" UNC	S11132122196	5.00	4.00
KWESOB DIA 5.00 SQ 4.00 NO. 10UNC	S11132122157	5.00	4.00
KWESOB DIA 5.60 SQ 4.50 7/32" UNC	S11132123197	5.60	4.50
KWESOB DIA 5.60 SQ 4.50 NO. 12UNC	S11132123158	5.60	4.50
KWESOB DIA 6.30 SQ 5.00 1/4" UNC	S11132124159	6.30	5.00
KWESOB DIA 6.30 SQ 5.00 5/16" UNC	S11132124161	6.30	5.00
KWESOB DIA 7.10 SQ 5.60 3/8" UNC	S11132125164	7.10	5.60
KWESOB DIA 8.00 SQ 6.30 5/16" UNC	S11132126161	8.00	6.30

Note: All Dimensions are in mm
For DIN Standard Numbers and more technical details please see page number 212-215

**Quick Change Tap Adaptor (KWES../B)
(With Safety Clutch)**

As per (DIN) Standards

Item Name	Item Code	Dia	Square
WESOB DIA 2.50 SQ 2.10 M1	S11132141135	2.50	2.10
KWESOB DIA 2.50 SQ 2.10 M1.8	S11132141136	2.50	2.10
KWESOB DIA 2.80 SQ 2.10 M2	S11132142194	2.80	2.10
KWESOB DIA 2.80 SQ 2.10 M2.5	S11132142103	2.80	2.10
KWESOB DIA 2.80 SQ 2.10 M3	S11132142104	2.80	2.10
KWESOB DIA 2.80 SQ 2.10 M4	S11132142105	2.80	2.10
KWESOB DIA 2.80 SQ 2.24 M2.2	S11132223102	2.80	2.24
KWESOB DIA 2.80 SQ 2.24 M2.5	S11132223103	2.80	2.24
KWESOB DIA 3.50 SQ 2.70 M3	S11132143104	3.50	2.70
KWESOB DIA 3.50 SQ 2.70 M5	S11132143108	3.50	2.70
KWESOB DIA 4.00 SQ 3.00 M3.5	S11132144106	4.00	3.00
KWESOB DIA 4.00 SQ 3.00 M4	S11132144105	4.00	3.00
KWESOB DIA 4.50 SQ 3.40 M4	S11132145105	4.50	3.40
KWESOB DIA 4.50 SQ 3.40 M6	S11132145109	4.50	3.40
KWESOB DIA 6.00 SQ 4.90 M5	S11132146108	6.00	4.90
KWESOB DIA 6.00 SQ 4.90 M6	S11132146109	6.00	4.90
KWESOB DIA 6.00 SQ 4.90 M8	S11132146111	6.00	4.90
KWESOB DIA 7.00 SQ 5.50 M9	S11132147142	7.00	5.50
KWESOB DIA 7.00 SQ 5.50 M10	S11132147112	7.00	5.50
KWESOB DIA 8.00 SQ 6.20 M8	S11132148111	8.00	6.20
KWESOB DIA 2.50 SQ 2.10 NO.01 UNC	S11132141201	2.50	2.10
KWESOB DIA 2.80 SQ 2.10 3/32" UNC	S11132142202	2.80	2.10
KWESOB DIA 2.80 SQ 2.10 5/32" UNC	S11132142203	2.80	2.10
KWESOB DIA 3.50 SQ 2.70 1/8" UNC	S11132143207	3.50	2.70
KWESOB DIA 4.00 SQ 3.00 7/32" UNC	S11132144197	4.00	3.00
KWESOB DIA 4.50 SQ 3.40 1/4" UNC	S11132145159	4.50	3.40
KWESOB DIA 4.50 SQ 3.40 5/32" UNC	S11132145203	4.50	3.40
KWESOB DIA 7.00 SQ 5.50 1/4" UNC	S11132147159	7.00	5.50
KWESOB DIA 7.00 SQ 5.50 1/8" G(BSP)	S11132147207	7.00	5.50
KWESOB DIA 7.00 SQ 5.50 3/8" G(BSP)	S11132147206	7.00	5.50
KWESOB DIA 8.00 SQ 6.20 5/16" UNC	S11132148161	8.00	6.20

Note: All Dimensions are in mm
For DIN Standard Numbers and more technical details please see page number 212-215

**Quick Change Tap Adaptor (KWES../B)
(With Safety Clutch)**

As per (JIS) Standards

Item Name	Item Code	Dia	Square
KWES0B DIA 4.00 SQ 3.00 M3	S11132144104	4.00	3.00
KWES0B DIA 4.00 SQ 3.00 M3.5	S11132144106	4.00	3.00
KWES0B DIA 4.00 SQ 3.20 M3	S11132163104	4.00	3.20
KWES0B DIA 5.00 SQ 4.00 M4	S11132122105	5.00	4.00
KWES0B DIA 5.00 SQ 4.00 M4.5	S11132122107	5.00	4.00
KWES0B DIA 5.50 SQ 4.50 M4.5	S11132164107	5.50	4.50
KWES0B DIA 5.50 SQ 4.50 M5	S11132164108	5.50	4.50
KWES0B DIA 5.50 SQ 4.50 M5.5	S11132164141	5.50	4.50
KWES0B DIA 6.00 SQ 4.50 M6	S11132165109	6.00	4.50
KWES0B DIA 6.20 SQ 5.00 M7	S11132167110	6.20	5.00
KWES0B DIA 6.20 SQ 5.00 M8	S11132167111	6.20	5.00
KWES0B DIA 7.00 SQ 5.50 M9	S11132147142	7.00	5.50
KWES0B DIA 7.00 SQ 5.50 M10	S11132147112	7.00	5.50
KWES0B DIA 8.00 SQ 6.00 M11	S11132168143	8.00	6.00

As per (ANSI) (US) Standards

KWES0B DIA 0.141" SQ 0.110" NO. 06"UNC	S11132191155	0.141"	0.110"
KWES0B DIA 0.168" SQ 0.131" NO. 08" UNC	S11132192190	0.168"	0.131"
KWES0B DIA 0.194" SQ 0.152" NO. 10 UNC	S11132198157	0.194"	0.152"
KWES0B DIA 0.220" SQ 0.165" NO. 12 UNC	S11132199158	0.220"	0.165"
KWES0B DIA 0.255" SQ 0.191" 1/4" UNC	S11132200159	0.255"	0.191"

Note: All Dimensions are in mm
For DIN Standard Numbers and more technical details please see page number 212-215

**Quick Change Tap Adaptor (KWES../B)
(With Safety Clutch)**

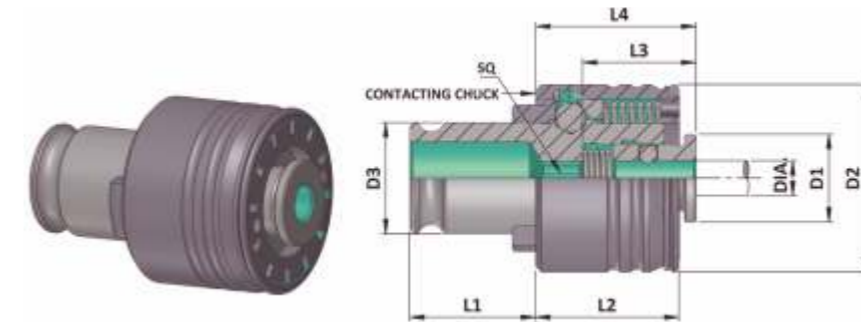

KWES1B Tap Adaptor

Item Name	Capacity	Shank Dia.	Suitable Chuck Size	D1	D2	D3	L1	L2	L3	L4
KWES 1 B	M3 - M12	3.5 - 11.2	1	19	32	19	21.5	25	17	25

As per (ISO) (529 -1975) Standards

Item Name	Item Code	Dia	Square
KWES1B DIA 3.15 SQ 2.50 M3	S11133118104	3.15	2.50
KWES1B DIA 3.15 SQ 2.50 M4	S11133118105	3.15	2.50
KWES1B DIA 3.55 SQ 2.80 M3	S11133119104	3.55	2.80
KWES1B DIA 3.55 SQ 2.80 M3.5	S11133119106	3.55	2.80
KWES1B DIA 3.55 SQ 2.80 M4.5	S11133119107	3.55	2.80
KWES1B DIA 4.00 SQ 3.15 M4	S11133120105	4.00	3.15
KWES1B DIA 4.00 SQ 3.15 M5	S11133120108	4.00	3.15
KWES1B DIA 4.50 SQ 3.55 M6	S11133121109	4.50	3.55
KWES1B DIA 5.00 SQ 4.00 M5	S11133122108	5.00	4.00
KWES1B DIA 5.60 SQ 4.50 M6	S11133123109	5.60	4.50
KWES1B DIA 5.60 SQ 4.50 M7	S11133123110	5.60	4.50
KWES1B DIA 6.30 SQ 5.00 M6	S11133124109	6.30	5.00
KWES1B DIA 6.30 SQ 5.00 M8	S11133124111	6.30	5.00
KWES1B DIA 7.10 SQ 5.60 M8	S11133125111	7.10	5.60
KWES1B DIA 7.10 SQ 5.60 M10	S11133125112	7.10	5.60
KWES1B DIA 8.00 SQ 6.30 M8	S11133126111	8.00	6.30
KWES1B DIA 8.00 SQ 6.30 M10	S11133126112	8.00	6.30
KWES1B DIA 9.00 SQ 7.10 M12	S11133127113	9.00	7.10
KWES1B DIA 10.00 SQ 8.00 M10	S11133128112	10.00	8.00
KWES1B DIA 11.20 SQ 9.00 M14	S11133129114	11.20	9.00
KWES1B DIA 3.15 SQ 2.50 NO. 04UNC	S11133118188	3.15	2.50
KWES1B DIA 3.15 SQ 2.50 NO. 05UNC	S11133118189	3.15	2.50
KWES1B DIA 3.15 SQ 2.50 NO. 08UNC	S11133118156	3.15	2.50
KWES1B DIA 3.55 SQ 2.80 NO. 06UNC	S11133119155	3.55	2.80
KWES1B DIA 3.55 SQ 2.80 NO. 10UNC	S11133119157	3.55	2.80
KWES1B DIA 3.55 SQ 2.80 3/16" UNC	S11133119196	3.55	2.80
KWES1B DIA 4.00 SQ 3.15 NO. 12UNC	S11133120158	4.00	3.15
KWES1B DIA 4.00 SQ 3.15 7/32" UNC	S11133120197	4.00	3.15
KWES1B DIA 4.50 SQ 3.55 NO. 08UNC	S11133121156	4.50	3.55
KWES1B DIA 4.50 SQ 3.55 1/4" UNC	S11133121159	4.50	3.55

Note: All Dimensions are in mm
For DIN Standard Numbers and more technical details please see page number 212-215

**Quick Change Tap Adaptor (KWES../B)
(With Safety Clutch)**

As per (ISO) (529 -1975) Standards

Item Name	Item Code	Dia	Square
KWES1B DIA 5.00 SQ 4.00 NO. 10UNC	S11133122157	5.00	4.00
KWES1B DIA 5.00 SQ 4.00 3/16" UNC	S11133122196	5.00	4.00
KWES1B DIA 5.60 SQ 4.50 NO. 12UNC	S11133123158	5.60	4.50
KWES1B DIA 5.60 SQ 4.50 7/32" UNC	S11133123197	5.60	4.50
KWES1B DIA 6.30 SQ 5.00 1/4" UNC	S11133124159	6.30	5.00
KWES1B DIA 6.30 SQ 5.00 5/16" UNC	S11133124161	6.30	5.00
KWES1B DIA 7.10 SQ 5.60 3/8" UNC	S11133125164	7.10	5.60
KWES1B DIA 8.00 SQ 6.30 5/16" UNC	S11133126161	8.00	6.30
KWES1B DIA 8.00 SQ 6.30 7/16" UNC	S11133126162	8.00	6.30
KWES1B DIA 9.00 SQ 7.10 1/2" UNC	S11133127163	9.00	7.10
KWES1B DIA 10.00 SQ 8.00 1/4" G(BSP)	S11133128205	10.00	8.00
KWES1B DIA 10.00 SQ 8.00 1/8" (BSPT)	S11133128242	10.00	8.00
KWES1B DIA 10.00 SQ 8.00 3/8" UNC	S11133128164	10.00	8.00
KWES1B DIA 11.20 SQ 9.00 1/4" G(BSP)	S11133129205	11.20	9.00
KWES1B DIA 11.20 SQ 9.00 9/16" UNC	S11133129166	11.20	9.00

As per (DIN) Standards

KWES1B DIA 2.50 SQ 2.10 M1.6	S11133141239	2.50	2.10
KWES1B DIA 2.50 SQ 2.10 M1.8	S11133141136	2.50	2.10
KWES1B DIA 2.50 SQ 2.10 M2	S11133141194	2.50	2.10
KWES1B DIA 2.50 SQ 2.10 M2.5	S11133141103	2.50	2.10
KWES1B DIA 2.80 SQ 2.10 M2	S11133142194	2.80	2.10
KWES1B DIA 2.80 SQ 2.10 M2.5	S11133142103	2.80	2.10
KWES1B DIA 2.80 SQ 2.10 M3	S11133142104	2.80	2.10
KWES1B DIA 3.50 SQ 2.70 M3	S11133143104	3.50	2.70
KWES1B DIA 3.50 SQ 2.70 M4	S11133143105	3.50	2.70
KWES1B DIA 3.50 SQ 2.70 M5	S11133143108	3.50	2.70
KWES1B DIA 4.00 SQ 3.00 M3.5	S11133144106	4.00	3.00
KWES1B DIA 4.00 SQ 3.00 M4	S11133144105	4.00	3.00
KWES1B DIA 4.50 SQ 3.40 M4	S11133145105	4.50	3.40
KWES1B DIA 4.50 SQ 3.40 M6	S11133145109	4.50	3.40
KWES1B DIA 5.50 SQ 4.30 M7	S11133271110	5.50	4.30
KWES1B DIA 6.00 SQ 4.90 M5	S11133146108	6.00	4.90
KWES1B DIA 6.00 SQ 4.90 M6	S11133146109	6.00	4.90
KWES1B DIA 6.00 SQ 4.90 M8	S11133146111	6.00	4.90
KWES1B DIA 7.00 SQ 5.50 M7	S11133147110	7.00	5.50
KWES1B DIA 7.00 SQ 5.50 M9	S11133147142	7.00	5.50
KWES1B DIA 7.00 SQ 5.50 M10	S11133147112	7.00	5.50
KWES1B DIA 8.00 SQ 6.20 M8	S11133148111	8.00	6.20
KWES1B DIA 8.00 SQ 6.20 M10	S11133148112	8.00	6.20
KWES1B DIA 9.00 SQ 7.00 M12	S11133149113	9.00	7.00
KWES1B DIA 10.00 SQ 8.00 M10	S11133128112	10.00	8.00
KWES1B DIA 11.00 SQ 9.00 M14	S11133150114	11.00	9.00

Continued...

Note: All Dimensions are in mm
For DIN Standard Numbers and more technical details please see page number 212-215

**Quick Change Tap Adaptor (KWES../B)
(With Safety Clutch)**

As per (DIN) Standards

Item Name	Item Code	Dia	Square
KWES1B DIA 2.50 SQ 2.10 1/16" UNC	S11133141201	2.50	2.10
KWES1B DIA 2.80 SQ 2.10 3/32" UNC	S11133142202	2.80	2.10
KWES1B DIA 2.80 SQ 2.10 5/32" UNC	S11133142203	2.80	2.10
KWES1B DIA 3.50 SQ 2.70 1/8" UNC	S11133143207	3.50	2.70
KWES1B DIA 4.00 SQ 3.00 7/32" UNC	S11133144197	4.00	3.00
KWES1B DIA 4.50 SQ 3.40 1/4" UNC	S11133145159	4.50	3.40
KWES1B DIA 4.50 SQ 3.40 5/32" UNC	S11133145203	4.50	3.40
KWES1B DIA 7.00 SQ 5.50 1/4" UNC	S11133147159	7.00	5.50
KWES1B DIA 7.00 SQ 5.50 1/8" (BSPT)	S11133147204	7.00	5.50
KWES1B DIA 7.00 SQ 5.50 3/8" UNC	S11133147164	7.00	5.50
KWES1B DIA 8.00 SQ 6.20 1/8" G (BSPT)	S11133148242	8.00	6.20
KWES1B DIA 8.00 SQ 6.20 5/16" UNC	S11133148161	8.00	6.20
KWES1B DIA 8.00 SQ 6.20 7/16" UNC	S11133148162	8.00	6.20
KWES1B DIA 9.00 SQ 7.00 3/8" UNC	S11133149164	9.00	7.00
KWES1B DIA 9.00 SQ 7.00 1/2" UNC	S11133149163	9.00	7.00
KWES1B DIA 11.00 SQ 9.00 1/4" G(BSP)	S11133150205	11.00	9.00
KWES1B DIA 11.00 SQ 9.00 9/16" UNC	S11133150166	11.00	9.00

As per (JIS) Standards

KWES1B DIA 4.00 SQ 3.00 M3	S11133144104	4.00	3.00
KWES1B DIA 4.00 SQ 3.00 M3.5	S11133144106	4.00	3.00
KWES1B DIA 4.00 SQ 3.20 M3	S11133163104	4.00	3.20
KWES1B DIA 4.00 SQ 3.20 M4	S11133163105	4.00	3.20
KWES1B DIA 5.00 SQ 4.00 M4	S11133122105	5.00	4.00
KWES1B DIA 5.00 SQ 4.00 M4.5	S11133122107	5.00	4.00
KWES1B DIA 5.50 SQ 4.50 M5	S11133164108	5.50	4.50
KWES1B DIA 5.50 SQ 4.50 M5.5	S11133164141	5.50	4.50
KWES1B DIA 5.50 SQ 4.50 M7	S11133164110	5.50	4.50
KWES1B DIA 6.00 SQ 4.50 M6	S11133165109	6.00	4.50
KWES1B DIA 6.20 SQ 5.00 M7	S11133167110	6.20	5.00
KWES1B DIA 6.20 SQ 5.00 M8	S11133167111	6.20	5.00
KWES1B DIA 7.00 SQ 5.50 M9	S11133147142	7.00	5.50
KWES1B DIA 7.00 SQ 5.50 M10	S11133147112	7.00	5.50
KWES1B DIA 8.00 SQ 6.00 M11	S11133168143	8.00	6.00
KWES1B DIA 8.50 SQ 6.50 M12	S11133170113	8.50	6.50
KWES1B DIA 9.00 SQ 7.00 1/2" UNC	S11133149163	9.00	7.00
KWES1B DIA 10.50 SQ 8.00 M14	S11133172114	10.50	8.00
KWES1B DIA 10.50 SQ 8.00 M15	S11133172144	10.50	8.00
KWES1B DIA 11.00 SQ 9.00 1/4" G(BSP)	S11133150205	11.00	9.00

Note: All Dimensions are in mm

For DIN Standard Numbers and more technical details please see page number 212-215

**Quick Change Tap Adaptor (KWES../B)
(With Safety Clutch)**

As per (ANSI) (US) Standards

Item Name	Item Code	Dia	Square
KWES1B DIA 0.141" SQ 0.110" NO. 06UNC	S11133191155	0.141"	0.110"
KWES1B DIA 0.168" SQ 0.131" NO. 08UNC	S11133192156	0.168"	0.131"
KWES1B DIA 0.194" SQ 0.152" NO. 10UNC	S11133198157	0.194"	0.152"
KWES1B DIA 0.220" SQ 0.165" NO. 12UNC	S11133199158	0.220"	0.165"
KWES1B DIA 0.255" SQ 0.191" 1/4" UNC	S11133200159	0.255"	0191"
KWES1B DIA 0.312" SQ 0.234" 1/8" SS	S11133225160	0.312"	0.234"
KWES1B DIA 0.318" SQ 0.238" 5/16" UNC	S11133202161	0.318"	0.238"
KWES1B DIA 0.323" SQ 0.242" 7/16" UNC	S11133193162	0.323"	0.242"
KWES1B DIA 0.367" SQ 0.275" 1/2" UNC	S11133194163	0.367"	0.275"
KWES1B DIA 0.381" SQ 0.286" 3/8" UNC	S11133195164	0.381"	0.286"
KWES1B DIA 0.429" SQ 0.322" 1/4" NPT	S11133196248	0.429"	0.322"
KWES1B DIA 0.429" SQ 0.322" 9/16" UNC	S11133196166	0.429"	0.322"
KWES1B DIA 0.437" SQ 0.328 1/8" LS	S11133197165	0.437"	0.328"

**Quick Change Tap Adaptor (KWES../B)
(With Safety Clutch)**

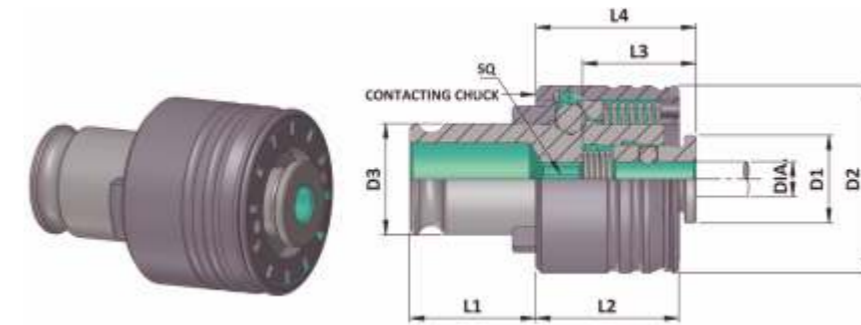

Technical Information

Item Name	Capacity	Shank Dia.	Suitable Chuck Size	D1	D2	D3	L1	L2	L3	L4
KWES 2 B	M8 - M20	6 - 18	2	30	50	31	35	31	30	34

As per (ISO) (529 -1975) Standards

Item Name	Item Code	Dia	Square
KWES2B DIA 6.30 SQ 5.00 M6	S11134124109	6.30	5.00
KWES2B DIA 6.30 SQ 5.00 M8	S11134124111	6.30	5.00
KWES2B DIA 7.10 SQ 5.60 M7	S11134125110	7.10	5.60
KWES2B DIA 7.10 SQ 5.60 M10	S11134125112	7.10	5.60
KWES2B DIA 8.00 SQ 6.30 M8	S11134126111	8.00	6.30
KWES2B DIA 8.00 SQ 6.30 M10	S11134126112	8.00	6.30
KWES2B DIA 9.00 SQ 7.10 M12	S11134127113	9.00	7.10
KWES2B DIA 10.00 SQ 8.00 M10	S11134128112	10.00	8.00
KWES2B DIA 10.00 SQ 8.00 M10	S11134128112	10.00	8.00
KWES2B DIA 10.00 SQ 8.00 M10	S11134128112	10.00	8.00
KWES2B DIA 14.00 SQ 11.20 M18	S11134131116	14.00	11.20
KWES2B DIA 14.00 SQ 11.20 M20	S11134131117	14.00	11.20
KWES2B DIA 16.00 SQ 12.50 M22	S11134132118	16.00	12.50
KWES2B DIA 18.00 SQ 14.00 M24	S11134133119	18.00	14.00
KWES2B DIA 6.30 SQ 5.00 1/4" UNC	S11134124159	6.30	5.00
KWES2B DIA 6.30 SQ 5.00 5/16" UNC	S11134124161	6.30	5.00
KWES2B DIA 7.10 SQ 5.60 3/8" UNC	S11134125164	7.10	5.60
KWES2B DIA 8.00 SQ 6.30 1/8" G(BSP)	S11134126204	8.00	6.30
KWES2B DIA 8.00 SQ 6.30 5/16" UNC	S11134126161	8.00	6.30
KWES2B DIA 8.00 SQ 6.30 7/16" UNC	S11134126162	8.00	6.30
KWES2B DIA 9.00 SQ 7.10 1/2" UNC	S11134127163	9.00	7.10
KWES2B DIA 10.00 SQ 8.00 1/4" G(BSP)	S11134128205	10.00	8.00
KWES2B DIA 10.00 SQ 8.00 3/8" UNC	S11134128164	10.00	8.00
KWES2B DIA 11.20 SQ 9.00 9/16" UNC	S11134129166	11.20	9.00
KWES2B DIA 12.50 SQ 10.00 3/8" G(BSP)	S11134130206	12.50	10.00
KWES2B DIA 12.50 SQ 10.00 5/8" UNC	S11134130168	12.50	10.00
KWES2B DIA 14.00 SQ 11.20 3/4" UNC	S11134131171	14.00	11.20
KWES2B DIA 16.00 SQ 12.50 1/12" G(BSP)	S11134132210	16.00	12.50
KWES2B DIA 16.00 SQ 12.50 7/8" UNC	S11134132174	16.00	12.50
KWES2B DIA 18.00 SQ 14.00 1/2" G(BSP)	S11134133210	18.00	14.00

**Quick Change Tap Adaptor (KWES../B)
(With Safety Clutch)**

As per (DIN) Standards

Item Name	Item Code	Dia	Square
KWES2B DIA 6.00 SQ 4.90 M5	S11134146108	6.00	4.90
KWES2B DIA 6.00 SQ 4.90 M6	S11134146109	6.00	4.90
KWES2B DIA 6.00 SQ 4.90 M8	S11134146111	6.00	4.90
KWES2B DIA 7.00 SQ 5.50 M7	S11134147110	7.00	5.50
KWES2B DIA 7.00 SQ 5.50 M9	S11134147142	7.00	5.50
KWES2B DIA 7.00 SQ 5.50 M10	S11134147112	7.00	5.50
KWES2B DIA 8.00 SQ 6.20 M8	S11134148111	8.00	6.20
KWES2B DIA 8.00 SQ 6.20 M10	S11134148112	8.00	6.20
KWES2B DIA 8.00 SQ 6.20 M11	S11134148143	8.00	6.20
KWES2B DIA 9.00 SQ 7.00 M12	S11134149113	9.00	7.00
KWES2B DIA 11.00 SQ 9.00 M14	S11134150114	11.00	9.00
KWES2B DIA 12.00 SQ 9.00 M16	S11134151115	12.00	9.00
KWES2B DIA 14.00 SQ 11.00 M18	S11134152116	14.00	11.00
KWES2B DIA 16.00 SQ 12.00 M20	S11134153117	16.00	12.00
KWES2B DIA 18.00 SQ 14.50 M22	S11134154118	18.00	14.50
KWES2B DIA 18.00 SQ 14.50 M24	S11134154119	18.00	14.50
KWES2B DIA 7.00 SQ 5.50 1/4" UNC	S11134147159	7.00	5.50
KWES2B DIA 7.00 SQ 5.50 1/8" G(BSP)	S11134147204	7.00	5.50
KWES2B DIA 7.00 SQ 5.50 3/8" UNC	S11134147164	7.00	5.50
KWES2B DIA 8.00 SQ 6.20 1/8" (BSPT)	S11134148242	8.00	6.20
KWES2B DIA 8.00 SQ 6.20 5/16" UNC	S11134148161	8.00	6.20
KWES2B DIA 8.00 SQ 6.20 7/16" UNC	S11134148162	8.00	6.20
KWES2B DIA 9.00 SQ 7.00 1/2" UNC	S11134149163	9.00	7.00
KWES2B DIA 9.00 SQ 7.00 3/8" UNC	S11134149164	9.00	7.00
KWES2B DIA 11.00 SQ 9.00 1/4" G(BSP)	S11134150205	11.00	9.00
KWES2B DIA 11.00 SQ 9.00 9/16" UNC	S11134150166	11.00	9.00
KWES2B DIA 12.00 SQ 9.00 3/8" G(BSP)	S11134151206	12.00	9.00
KWES2B DIA 12.00 SQ 9.00 5/8" UNC	S11134151168	12.00	9.00
KWES2B DIA 14.00 SQ 11.00 11/16" UNC	S11134152169	14.00	11.00
KWES2B DIA 14.00 SQ 11.00 Pg11	S11134152257	14.00	11.00
KWES2B DIA 16.00 SQ 12.00 1/2" G(BSP)	S11134153210	16.00	12.00
KWES2B DIA 16.00 SQ 12.00 1/4" G(BSP)	S11134153205	16.00	12.00
KWES2B DIA 16.00 SQ 12.00 13/16" UNC	S11134153172	16.00	12.00
KWES2B DIA 18.00 SQ 14.50 15/16" UNC	S11134154177	18.00	14.50
KWES2B DIA 18.00 SQ 14.50 5/8" G(BSP)	S11134154208	18.00	14.50
KWES2B DIA 18.00 SQ 14.50 7/8" UNC	S11134154174	18.00	14.50

Continued...

Note: All Dimensions are in mm
For DIN Standard Numbers and more technical details please see page number 212-215

**Quick Change Tap Adaptor (KWES../B)
(With Safety Clutch)**

As per (JIS) Standards

Item Name	Item Code	Dia	Square
KWES2B DIA 6.00 SQ 4.50 M6	S11134165109	6.00	4.50
KWES2B DIA 6.20 SQ 5.00 M7	S11134167110	6.20	5.00
KWES2B DIA 6.20 SQ 5.00 M8	S11134167111	6.20	5.00
KWES2B DIA 7.00 SQ 5.50 M9	S11134147142	7.00	5.50
KWES2B DIA 7.00 SQ 5.50 M10	S11134147112	7.00	5.50
KWES2B DIA 8.00 SQ 6.00 M11	S11134168143	8.00	6.00
KWES2B DIA 8.00 SQ 6.00 1/8" G(BSP)	S11134168204	8.00	6.00
KWES2B DIA 8.00 SQ 6.20 M11	S11134148143	8.00	6.20
KWES2B DIA 8.50 SQ 6.50 M12	S11134170113	8.50	6.50
KWES2B DIA 9.00 SQ 7.00 1/2" UNC	S11134149163	9.00	7.00
KWES2B DIA 10.50 SQ 8.00 M14	S11134172114	10.50	8.00
KWES2B DIA 10.50 SQ 8.00 M15	S11134172144	10.50	8.00
KWES2B DIA 11.00 SQ 9.00 1/4" G(BSP)	S11134150205	11.00	9.00
KWES2B DIA 12.00 SQ 9.00 5/8" UNC	S11134151168	12.00	9.00
KWES2B DIA 12.50 SQ 10.00 M16	S11134130115	12.50	10.00
KWES2B DIA 13.00 SQ 10.00 M17	S11134173145	13.00	10.00
KWES2B DIA 14.00 SQ 11.00 M18	S11134152116	14.00	11.00
KWES2B DIA 15.00 SQ 12.00 M20	S11134174117	15.00	12.00
KWES2B DIA 17.00 SQ 13.00 M22	S11134175118	17.00	13.00
KWES2B DIA 19.00 SQ 15.00 M24	S11134176119	19.00	15.00

As per (ANSI) (US) Standards

KWES2B DIA 0.255" SQ 0.191" 1/4" UNC	S11134200159	0.255"	0.191"
KWES2B DIA 0.312" SQ 0.234" 1/8" PSS	S11134225160	0.312"	0.234"
KWES2B DIA 0.318" SQ 0.238" 5/16" UNC	S11134202161	0.318"	0.238"
KWES2B DIA 0.323" SQ 0.242" 7/16" UNC	S11134193162	0.323"	0.242"
KWES2B DIA 0.367" SQ 0.275" 1/2" UNC	S11134194163	0.367"	0.275"
KWES2B DIA 0.381" SQ 0.286" 3/8" UNC	S11134195164	0.381"	0.286"
KWES2B DIA 0.429" SQ 0.322" 1/4" G(BSP)	S11134196205	0.429"	0.322"
KWES2B DIA 0.429" SQ 0.322" 1/4" NPT	S11134196248	0.429"	0.322"
KWES2B DIA 0.429" SQ 0.322" 9/16" UNC	S11134196166	0.429"	0.322"
KWES2B DIA 0.437" SQ 0.328" 1/8" PLS	S11134197167	0.437"	0.328"
KWES2B DIA 0.480" SQ 0.360" 5/8" UNC	S11134203168	0.480"	0.360"
KWES2B DIA 0.542" SQ 0.406" 11/16" UNC	S11134204169	0.542"	0.406"
KWES2B DIA 0.542" SQ 0.406" 3/8" NPT	S11134259243	0.542"	0.406"
KWES2B DIA 0.562" SQ 0.421" 1/4" P	S11134205170	0.562"	0.421"
KWES2B DIA 0.590" SQ 0.442" 3/4" UNC	S11134206171	0.590"	0.442"
KWES2B DIA 0.590" SQ 0.442" 3/4" UNC TC	S11134206252	0.590"	0.442"
KWES2B DIA 0.652" SQ 0.489" 13/16" UNC	S11134207172	0.652"	0.489"
KWES2B DIA 0.687" SQ 0.515" 1/2" P	S11134208173	0.687"	0.515"
KWES2B DIA 0.687" SQ 0.515" 5/8" G(BSP)	S11134208208	0.687"	0.515"
KWES2B DIA 0.697" SQ 0.523" 7/8" UNC	S11134209174	0.697"	0.523"
KWES2B DIA 0.700" SQ 0.531" 3/8" P	S11134210175	0.700"	0.531"

Note: All Dimensions are in mm
For DIN Standard Numbers and more technical details please see page number 212-215

**Quick Change Tap Adaptor (KWES../B)
(With Safety Clutch)**

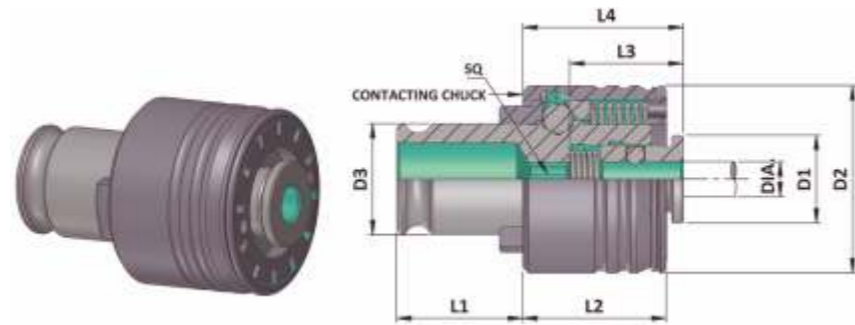

Technical Information

Item Name	Capacity	Shank Dia.	Suitable Chuck Size	D1	D2	D3	L1	L2	L3	L4
KWES 3 B	M14 - M33	11 - 28	3	48	72	48	55.5	41	44	45

As per (ISO) (529 -1975) Standards

Item Name	Item Code	Dia	Square
KWES3B DIA 11.20 SQ 9.00 M14	S11135129114	11.20	9.00
KWES3B DIA 12.50 SQ 10.00 M16	S11135130115	12.50	10.00
KWES3B DIA 14.00 SQ 11.20 M18	S11135131116	14.00	11.20
KWES3B DIA 14.00 SQ 11.20 M20	S11135131117	14.00	11.20
KWES3B DIA 16.00 SQ 12.50 M22	S11135132118	16.00	12.50
KWES3B DIA 18.00 SQ 14.00 M24	S11135133119	18.00	14.00
KWES3B DIA 20.00 SQ 16.00 M27	S11135134122	20.00	16.00
KWES3B DIA 20.00 SQ 16.00 M30	S11135134123	20.00	16.00
KWES3B DIA 22.40 SQ 18.00 M33	S11135135124	22.40	18.00
KWES3B DIA 25.00 SQ 20.00 M36	S11135136125	25.00	20.00
KWES3B DIA 28.00 SQ 22.40 M39 (FINE PITCH)	S11135137126	28.00	22.40
KWES3B DIA 28.00 SQ 22.40 M42 (FINE PITCH)	S11135137127	28.00	22.40
KWES3B DIA 11.20 SQ 9.00 9/16" UNC	S11135129166	11.20	9.00
KWES3B DIA 12.50 SQ 10.00 5/8" UNC	S11135130168	12.50	10.00
KWES3B DIA 14.00 SQ 11.20 11/16" UNC	S11135131169	14.00	11.20
KWES3B DIA 14.00 SQ 11.20 3/4" UNC	S11135131171	14.00	11.20
KWES3B DIA 16.00 SQ 12.50 7/8" UNC	S11135132174	16.00	12.50
KWES3B DIA 18.00 SQ 14.00 1" UNC	S11135133178	18.00	14.00
KWES3B DIA 20.00 SQ 16.00 1-1/8" UNC	S11135134179	20.00	16.00
KWES3B DIA 22.40 SQ 18.00 1-1/4" UNC	S11135135181	22.40	18.00
KWES3B DIA 25.00 SQ 20.00 1-3/8" UNC	S11135136182	25.00	20.00

Continued...

Note: All Dimensions are in mm
For DIN Standard Numbers and more technical details please see page number 212-215

**Quick Change Tap Adaptor (KWES../B)
(With Safety Clutch)**

As per (DIN) Standards

Item Name	Item Code	Dia	Square
KWES3B DIA 11.00 SQ 9.00 M14	S11135150114	11.00	9.00
KWES3B DIA 12.00 SQ 9.00 M16	S11135151115	12.00	9.00
KWES3B DIA 14.00 SQ 11.00 M18	S11135152116	14.00	14.00
KWES3B DIA 16.00 SQ 12.00 M20	S11135153117	16.00	12.00
KWES3B DIA 18.00 SQ 14.50 M22	S11135154118	18.00	14.50
KWES3B DIA 18.00 SQ 14.50 M24	S11135154119	18.00	14.50
KWES3B DIA 20.00 SQ 16.00 M27	S11135134122	20.00	16.00
KWES3B DIA 22.00 SQ 18.00 M30	S11135155123	22.00	18.00
KWES3B DIA 25.00 SQ 20.00 M33	S11135136124	25.00	20.00
KWES3B DIA 28.00 SQ 22.00 M36	S11135156125	28.00	22.00
KWES3B DIA 11.00 SQ 9.00 1/4" BSPT	S11135150255	11.00	9.00
KWES3B DIA 11.00 SQ 9.00 3/8" BSPT	S11135150256	11.00	9.00
KWES3B DIA 11.00 SQ 9.00 9/16" UNC	S11135150166	11.00	9.00
KWES3B DIA 12.00 SQ 9.00 3/8" BSPT	S11135151256	12.00	9.00
KWES3B DIA 12.00 SQ 9.00 5/8" UNC	S11135151168	12.00	9.00
KWES3B DIA 14.00 SQ 11.00 11/16" UNC	S11135152169	14.00	11.00
KWES3B DIA 16.00 SQ 12.00 1/2" G(BSP)	S11135153210	16.00	12.00
KWES3B DIA 16.00 SQ 12.00 13/16" UNC	S11135153172	16.00	12.00
KWES3B DIA 18.00 SQ 14.50 15/16" UNC	S11135154177	18.00	14.50
KWES3B DIA 18.00 SQ 14.50 5/8" G(BSP)	S11135154208	18.00	14.50
KWES3B DIA 18.00 SQ 14.50 7/8" UNC	S11135154174	18.00	14.50
KWES3B DIA 20.00 SQ 16.00 1" UNC	S11135134178	20.00	16.00
KWES3B DIA 20.00 SQ 16.00 3/4" G(BSP)	S11135134209	20.00	16.00
KWES3B DIA 22.00 SQ 18.00 1-1/8" UNC	S11135155179	22.00	18.00
KWES3B DIA 22.00 SQ 18.00 7/8" G(BSP)	S11135155211	22.00	18.00
KWES3B DIA 25.00 SQ 20.00 1" G(BSP)	S11135136212	25.00	20.00
KWES3B DIA 25.00 SQ 20.00 1-1/4" UNC	S11135136181	25.00	20.00
KWES3B DIA 28.00 SQ 22.00 1-1/8" G(BSP)	S11135156213	28.00	22.00
KWES3B DIA 28.00 SQ 22.00 1-3/8" UNC	S11135156182	28.00	22.00

Note: All Dimensions are in mm
For DIN Standard Numbers and more technical details please see page number 212-215

**Quick Change Tap Adaptor (KWES../B)
(With Safety Clutch)**

As per (JIS) Standards

Item Name	Item Code	Dia	Square
KWES3B DIA 12.50 SQ 10.00 M16	S11135130115	12.50	10.00
KWES3B DIA 13.00 SQ 10.00 M17	S11135173145	13.00	10.00
KWES3B DIA 14.00 SQ 11.00 M18	S11135152116	14.00	11.00
KWES3B DIA 15.00 SQ 12.00 M20	S11135174117	15.00	12.00
KWES3B DIA 17.00 SQ 13.00 M22	S11135175118	17.00	13.00
KWES3B DIA 19.00 SQ 15.00 M24	S11135176119	19.00	15.00
KWES3B DIA 19.00 SQ 15.00 M25	S11135176147	19.00	15.00
KWES3B DIA 20.00 SQ 15.00 M26	S11135177148	20.00	15.00
KWES3B DIA 20.00 SQ 15.00 M27	S11135177122	20.00	15.00
KWES3B DIA 21.00 SQ 17.00 M28	S11135178149	21.00	17.00
KWES3B DIA 23.00 SQ 17.00 M30	S11135180123	23.00	17.00
KWES3B DIA 24.00 SQ 19.00 M32	S11135181150	24.00	19.00
KWES3B DIA 25.00 SQ 19.00 M33	S11135186124	25.00	19.00
KWES3B DIA 26.00 SQ 21.00 M34	S11135182151	26.00	21.00
KWES3B DIA 26.00 SQ 21.00 M35	S11135182152	26.00	21.00
KWES3B DIA 28.00 SQ 21.00 M36	S11135187125	28.00	21.00
KWES3B DIA 28.00 SQ 21.00 M38	S11135187153	28.00	21.00
KWES3B DIA 30.00 SQ 23.00 M39	S11135183138	30.00	23.00
KWES3B DIA 30.00 SQ 23.00 M40	S11135183154	30.00	23.00
KWES3B DIA 11.00 SQ 9.00 1/4" BSPT	S11135150255	11.00	9.00
KWES3B DIA 12.00 SQ 9.00 5/8" UNC	S11135151168	12.00	9.00

As per (ANSI) (US) Standards

KWES3B DIA 0.652" SQ 0.489" 13/16" UNC	S11135207176	0.652"	0.489"
KWES3B DIA 0.687" SQ 0.515" 1/2" G(BSP)	S11135208210	0.687"	0.515"
KWES3B DIA 0.687" SQ 0.515" 1/2" P	S11135208173	0.687"	0.515"
KWES3B DIA 0.697" SQ 0.523" 7/8" UNC	S11135209174	0.697"	0.523"
KWES3B DIA 0.700" SQ 0.531" 3/8" P	S11135210175	0.700"	0.531"
KWES3B DIA 0.760" SQ 0.570" 15/16" UNC	S11135211177	0.760"	0.570"
KWES3B DIA 0.800" SQ 0.600" 1" UNC	S11135212178	0.800"	0.600"
KWES3B DIA 0.896" SQ 0.672" 1-1/8" UNC	S11135213179	0.896"	0.672"
KWES3B DIA 0.906" SQ 0.679" 3/4" P	S11135214180	0.906"	0.679"
KWES3B DIA 1.021" SQ 0.766" 1-1/4" UNC	S11135215181	1.021"	0.766"
KWES3B DIA 1.108" SQ 0.831" 1-3/8" UNC	S11135216182	1.108"	0.831"
KWES3B DIA 1.125" SQ 0.843" 1" P	S11135217183	1.125"	0.843"

Note: All Dimensions are in mm
For DIN Standard Numbers and more technical details please see page number 212-215

**Quick Change Tap Adaptor (KWES../B)
(With Safety Clutch)**

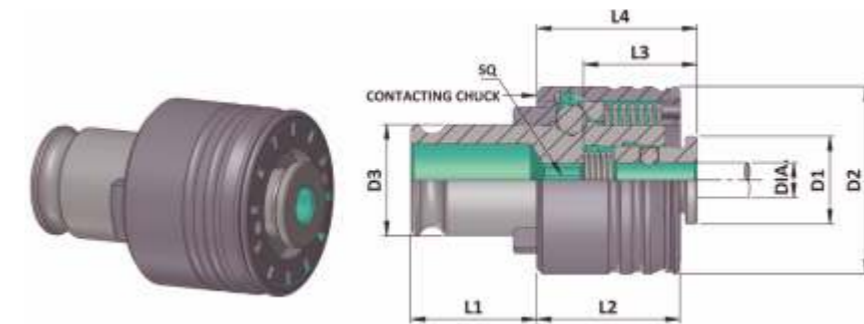

Technical Information

Item Name	Capacity	Shank Dia.	Suitable Chuck Size	D1	D2	D3	L1	L2	L3	L4
KWES 4 B	M22 - M48	18 - 36	4	60	95	60	63	61	71	68

As per (ISO) (529 -1975) Standards

Item Name	Item Code	Dia	Square
KWES4B DIA 16.00 SQ 12.50 M22	S11136132118	16.00	12.50
KWES4B DIA 18.00 SQ 14.00 M24	S11136133119	18.00	14.00
KWES4B DIA 20.00 SQ 16.00 M27	S11136134122	20.00	16.00
KWES4B DIA 20.00 SQ 16.00 M30	S11136134123	20.00	16.00
KWES4B DIA 22.40 SQ 18.00 M33	S11136135124	22.40	18.00
KWES4B DIA 25.00 SQ 20.00 M36	S11136136125	25.00	20.00
KWES4B DIA 28.00 SQ 22.40 M39	S11136137138	28.00	22.40
KWES4B DIA 28.00 SQ 22.40 M42	S11136137129	28.00	22.40
KWES4B DIA 31.50 SQ 25.00 M45	S11136138130	31.50	25.00
KWES4B DIA 31.50 SQ 25.00 M48	S11136138131	31.50	25.00
KWES4B DIA 35.50 SQ 28.00 M52 (FINE PITCH)	S11136139132	35.50	28.00
KWES4B DIA 35.50 SQ 28.00 M56 (FINE PITCH)	S11136139133	35.50	28.00
KWES4B DIA 16.00 SQ 12.50 7/8" UNC	S11136132174	16.00	12.50
KWES4B DIA 18.00 SQ 14.00 1" UNC	S11136133178	18.00	14.00
KWES4B DIA 20.00 SQ 16.00 1-1/8" UNC	S11136134179	20.00	16.00
KWES4B DIA 22.40 SQ 18.00 1-1/4" UNC	S11136135181	22.40	18.00
KWES4B DIA 25.00 SQ 20.00 1-3/8" UNC	S11136136182	25.00	20.00
KWES4B DIA 28.00 SQ 22.40 1-1/2" UNC	S11136137184	28.00	22.40
KWES4B DIA 31.50 SQ 25.00 1-3/4" UNC	S11136138186	31.50	25.00
KWES4B DIA 35.50 SQ 28.00 2" UNC	S11136139198	35.50	28.00

Note: All Dimensions are in mm
For DIN Standard Numbers and more technical details please see page number 212-215

**Quick Change Tap Adaptor (KWES../B)
(With Safety Clutch)**

As per (DIN) Standards

Item Name	Item Code	Dia	Square
KWES4B DIA 18.00 SQ 14.50 M22	S11136154118	18.00	14.50
KWES4B DIA 18.00 SQ 14.50 M24	S11136154119	18.00	14.50
KWES4B DIA 20.00 SQ 16.00 M27	S11136134122	20.00	16.00
KWES4B DIA 22.00 SQ 18.00 M30	S11136155123	22.00	18.00
KWES4B DIA 25.00 SQ 20.00 M33	S11136136124	25.00	20.00
KWES4B DIA 28.00 SQ 22.00 M36	S11136156125	28.00	22.00
KWES4B DIA 32.00 SQ 24.00 M39	S11136157138	32.00	24.00
KWES4B DIA 32.00 SQ 24.00 M42	S11136157129	32.00	24.00
KWES4B DIA 32.00 SQ 24.00 M45	S11136157130	32.00	24.00
KWES4B DIA 36.00 SQ 29.00 M45	S11136158130	36.00	29.00
KWES4B DIA 36.00 SQ 29.00 M48	S11136158131	36.00	29.00
KWES4B DIA 18.00 SQ 14.50 1/2" NPT	S11136154253	18.00	14.50
KWES4B DIA 18.00 SQ 14.50 15/16" UNC	S11136154177	18.00	14.50
KWES4B DIA 18.00 SQ 14.50 3/8" NPT	S11136154243	18.00	14.50
KWES4B DIA 18.00 SQ 14.50 5/8" G(BSP)	S11136154208	18.00	14.50
KWES4B DIA 18.00 SQ 14.50 7/8" UNC	S11136154174	18.00	14.50
KWES4B DIA 20.00 SQ 16.00 1" UNC	S11136134178	20.00	16.00
KWES4B DIA 20.00 SQ 16.00 3/4" G(BSP)	S11136134209	20.00	16.00
KWES4B DIA 22.00 SQ 18.00 1-1/8" UNC	S11136155179	22.00	18.00
KWES4B DIA 22.00 SQ 18.00 7/8" G(BSP)	S11136155211	22.00	18.00
KWES4B DIA 25.00 SQ 20.00 1" G(BSP)	S11136136212	25.00	20.00
KWES4B DIA 25.00 SQ 20.00 1-1/4" UNC	S11136136181	25.00	20.00
KWES4B DIA 28.00 SQ 22.00 1-1/8" G(BSP)	S11136156213	28.00	22.00
KWES4B DIA 28.00 SQ 22.00 1-3/8" UNC	S11136156182	28.00	22.00
KWES4B DIA 32.00 SQ 24.00 1-1/2" UNC	S11136157184	32.00	24.00
KWES4B DIA 32.00 SQ 24.00 1-1/4" G(BSP)	S11136157214	32.00	24.00
KWES4B DIA 32.00 SQ 24.00 1-5/8" UNC	S11136157219	32.00	24.00
KWES4B DIA 36.00 SQ 29.00 1-1/2" G(BSP)	S11136158216	36.00	29.00
KWES4B DIA 36.00 SQ 29.00 1-3/4" G(BSP)	S11136158217	36.00	29.00
KWES4B DIA 36.00 SQ 29.00 1-3/4" UNC	S11136158186	36.00	29.00
KWES4B DIA 36.00 SQ 29.00 1-3/8" G(BSP)	S11136158215	36.00	29.00
KWES4B DIA 36.00 SQ 29.00 1-7/8" UNC	S11136158220	36.00	29.00
KWES4B DIA 36.00 SQ 29.00 2" G(BSP)	S11136158218	36.00	29.00

Continued...

Note: All Dimensions are in mm
For DIN Standard Numbers and more technical details please see page number 212-215

**Quick Change Tap Adaptor (KWES../B)
(With Safety Clutch)**

As per (JIS) Standards

Item Name	Item Code	Dia	Square
KWES4B DIA 17.00 SQ 13.00 M22	S11136175118	17.00	13.00
KWES4B DIA 19.00 SQ 15.00 M24	S11136176119	19.00	15.00
KWES4B DIA 19.00 SQ 15.00 M25	S11136176147	19.00	15.00
KWES4B DIA 20.00 SQ 15.00 M26	S11136177148	20.00	15.00
KWES4B DIA 20.00 SQ 15.00 M27	S11136177122	20.00	15.00
KWES4B DIA 21.00 SQ 17.00 M28	S11136178149	21.00	17.00
KWES4B DIA 23.00 SQ 17.00 M30	S11136180123	23.00	17.00
KWES4B DIA 24.00 SQ 19.00 M32	S11136181150	24.00	19.00
KWES4B DIA 25.00 SQ 19.00 M33	S11136186124	25.00	19.00
KWES4B DIA 26.00 SQ 21.00 M34	S11136182151	26.00	21.00
KWES4B DIA 26.00 SQ 21.00 M35	S11136182152	26.00	21.00
KWES4B DIA 28.00 SQ 21.00 M36	S11136187125	28.00	21.00
KWES4B DIA 28.00 SQ 21.00 M38	S11136187153	28.00	21.00
KWES4B DIA 30.00 SQ 23.00 M39	S11136183138	30.00	23.00
KWES4B DIA 30.00 SQ 23.00 M40	S11136183154	30.00	23.00
KWES4B DIA 32.00 SQ 26.00 M42	S11136184129	32.00	26.00
KWES4B DIA 35.00 SQ 26.00 M45	S11136185130	35.00	26.00
KWES4B DIA 38.00 SQ 29.00 M48	S11136188131	38.00	29.00

As per (ANSI) (US) Standards

KWES4B DIA 0.800" SQ 0.600" 1" UNC	S11136212178	0.800"	0.600"
KWES4B DIA 0.896" SQ 0.672" 1-1/8" UNC	S11136213179	0.896"	0.672"
KWES4B DIA 0.906" SQ 0.679" 3/4" P	S11136214180	0.906"	0.679"
KWES4B DIA 1.021" SQ 0.766" 1-1/4" UNC	S11136215181	1.021"	0.766"
KWES4B DIA 1.108" SQ 0.831" 1-3/8" UNC	S11136216182	1.108"	0.831"
KWES4B DIA 1.125" SQ 0.843" 1" P	S11136217183	1.125"	0.843"
KWES4B DIA 1.233" SQ 0.925" 1-1/2" UNC	S11136218184	1.233"	0.925"
KWES4B DIA 1.312" SQ 0.984" 1-1/4" P	S11136219185	1.312"	0.984"
KWES4B DIA 1.430" SQ 1.072" 1-3/4" UNC	S11136221186	1.430"	1.072"
KWES4B DIA 1.500" SQ 1.125" 1-1/2" P	S11136222187	1.500"	1.125"

Note: All Dimensions are in mm
For DIN Standard Numbers and more technical details please see page number 212-215

Quick Change Tap Adaptor With Safety Clutch (KWESK../B)

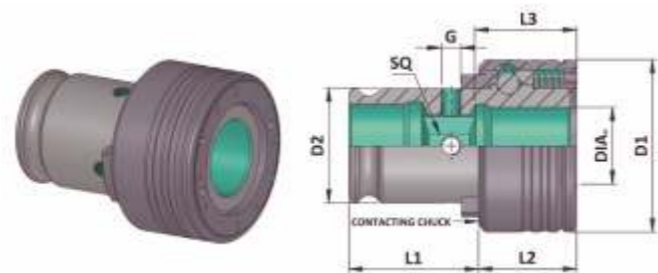

Technical Information

Item Name	Capacity	Shank Dia.	Suitable Chuck Size	D1	D2	L1	L2	L3
KWESK 1B	M16	> 11.2 - 12	1	32	19	21.5	25	27.5
KWESK 2B	M27 - M30	> 18 - 22	2	50	31	35	31	32.5
KWESK 3B	M39 - M48	> 28 - 36	3	72	48	55.5	41	40
KWESK 4B	M52 - M60	> 36 - 45	4	95	60	63	61	54

Quick Change Tap Adaptor (KWESK../B) (With Safety Clutch)

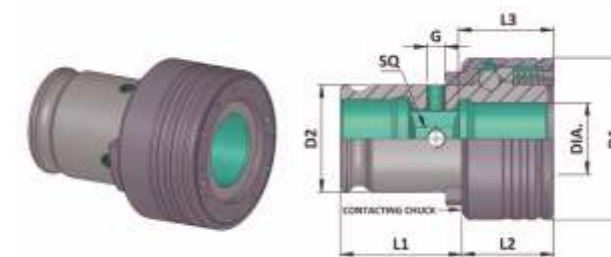

KWESK1B Tap Adaptor

Item Name	Capacity	Shank Dia.	Suitable Chuck Size	D1	D2	L1	L2	L3
KWESK 1B	M16	> 11.2 - 12	1	32	19	21.5	25	27.5

Item Name	Item Code	Dia	Square
KWESK1B DIA 12.00 SQ 9.00 3/8" G(BSP)	S11232151206	12.00	9.00
KWESK1B DIA 12.00 SQ 9.00 M16 (FINE PITCH)	S11232151115	12.00	9.00

KWESK2B Tap Adaptor

Item Name	Capacity	Shank Dia.	Suitable Chuck Size	D1	D2	L1	L2	L3
KWESK 2B	M27 - M30	> 18 - 22	2	50	31	35	31	32.5

Item Name	Item Code	Dia	Square
KWESK2B DIA 19.00 SQ 15.00 M25 (FINE PITCH)	S11134176146	19.00	15.00
KWESK2B DIA 20.00 SQ 15.00 M26 (FINE PITCH)	S11134177195	20.00	15.00
KWESK2B DIA 20.00 SQ 15.00 M27 (FINE PITCH)	S11134177120	20.00	15.00
KWESK2B DIA 20.00 SQ 16.00 3/4" G(BSP)	S11231134209	20.00	16.00
KWESK2B DIA 20.00 SQ 16.00 M27 (FINE PITCH)	S11134134120	20.00	16.00
KWESK2B DIA 20.00 SQ 16.00 M30 (FINE PITCH)	S11134134121	20.00	16.00
KWESK2B DIA 22.00 SQ 18.00 M30 (FINE PITCH)	S11231155123	22.00	18.00

Note: All Dimensions are in mm
For DIN Standard Numbers and more technical details please see page number 212-215

**Quick Change Tap Adaptor (KWESK../B)
(With Safety Clutch)**

KWESK3B Tap Adaptor

Item Name	Capacity	Shank Dia.	Suitable Chuck Size	D1	D2	L1	L2	L3
KWESK 3B	M39 - M48	> 28 - 36	3	72	48	55.5	41	40

Item Name	Item Code	Dia	Square
KWESK3B DIA 31.50 SQ 25.00 M36	S11135138125	31.50	25.00
KWESK3B DIA 31.50 SQ 25.00 M44 (FINE PITCH)	S11135138128	31.50	25.00
KWESK3B DIA 31.50 SQ 25.00 M48 (FINE PITCH)	S11135138140	31.50	25.00
KWESK3B DIA 32.00 SQ 24.00 1-1/4" G(BSP)	S11135157214	32.00	24.00
KWESK3B DIA 32.00 SQ 24.00 M39	S11135157138	32.00	24.00
KWESK3B DIA 32.00 SQ 24.00 M42	S11240157129	32.00	24.00
KWESK3B DIA 32.00 SQ 26.00 M42 (FINE PITCH)	S11135184129	32.00	26.00
KWESK3B DIA 35.00 SQ 26.00 M45 (FINE PITCH)	S11135185139	35.00	26.00
KWESK3B DIA 36.00 SQ 29.00 1-1/2" G(BSP)	S11135158216	36.00	29.00
KWESK3B DIA 36.00 SQ 29.00 1-3/4" G(BSP)	S11135158217	36.00	29.00
KWESK3B DIA 36.00 SQ 29.00 1-3/8" G(BSP)	S11135158215	36.00	29.00
KWESK3B DIA 36.00 SQ 29.00 2" G(BSP)	S11135158218	36.00	29.00
KWESK3B DIA 36.00 SQ 29.00 M45 (FINE PITCH)	S11135158139	36.00	29.00
KWESK3B DIA 36.00 SQ 29.00 M48 (FINE PITCH)	S11135158140	36.00	29.00
KWESK3B DIA 38.00 SQ 29.00 M48 (FINE PITCH)	S11135188140	38.00	29.00

KWESK4B Tap Adaptor

Item Name	Capacity	Shank Dia.	Suitable Chuck Size	D1	D2	L1	L2	L3
KWESK 4B	M52 - M60	> 36 - 45	4	95	60	63	61	54

Item Name	Item Code	Dia	Square
KWESK4B DIA 40.00 SQ 31.50 2-1/2" UNC	S11136220200	40.00	31.50
KWESK4B DIA 40.00 SQ 31.50 2-1/4" UNC	S11136220199	40.00	31.50
KWESK4B DIA 40.00 SQ 31.50 M60 (FINE PITCH)	S11136220134	40.00	31.50
KWESK4B DIA 40.00 SQ 32.00 1-7/8" UNC	S11136160220	40.00	32.00
KWESK4B DIA 40.00 SQ 32.00 2-1/4" G(BSP)	S11136160221	40.00	32.00
KWESK4B DIA 40.00 SQ 32.00 M52 (FINE PITCH)	S11136160132	40.00	32.00
KWESK4B DIA 40.00 SQ 32.00 M56 (FINE PITCH)	S11230160232	40.00	32.00
KWESK4B DIA 40.00 SQ 32.00 2" UNC	S11136160198	40.00	32.00
KWESK4B DIA 45.00 SQ 35.00 2-1/2" G(BSP)	S11136161222	45.00	35.00
KWESK4B DIA 45.00 SQ 35.00 2-1/4" UNC	S11136161199	45.00	35.00
KWESK4B DIA 45.00 SQ 35.00 M56 (FINE PITCH)	S11136161133	45.00	35.00
KWESK4B DIA 45.00 SQ 35.00 M60 (FINE PITCH)	S11136161134	45.00	35.00

Note: All Dimensions are in mm
For DIN Standard Numbers and more technical details please see page number 214-215

**Quick Change Tap Adaptor
Reduction Socket (KWRE)**

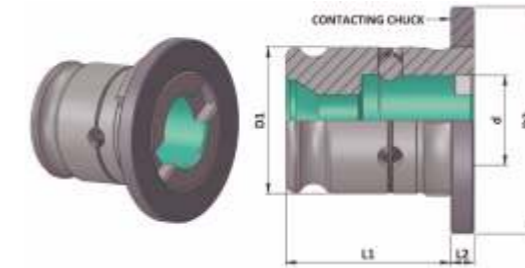

Reduction Socket (KWRE)

Item Name	Item Code	Suitable Chuck Size	Adaptor Size	d	D1	D2	L1	L2
KWRE 1/0	S11219254193	1	0	13	19	30	21.5	4
KWRE 2/1	S11219249193	2	1	19	31	48	35	5
KWRE 3/1	S11219250193	3	1	19	48	70	55.5	6
KWRE 3/2	S11219251193	3	2	31	48	70	55.5	6
KWRE 4/2	S11219252193	4	2	31	60	92	63	13
KWRE 4/3	S11219253193	4	3	48	60	92	63	13

Tap Shank Dimensions ISO 529 - 1975

Dimension Dia. x Square	Metric		UNC		UNF		BSW		BSF		BA	
	Shank dia.	Shank dia.	Shank dia.	Shank dia.	Shank dia.	Shank dia.	Shank dia.	Shank dia.	Shank dia.	Shank dia.	Shank dia.	Shank dia.
3.15 x 2.5	M4	M3	-	No. 4-40	-	No. 4-48	-	-	-	-	-	No. 5
	-	-	No. 8-32	No. 5-40	No. 8-36	No. 5-44	-	-	-	-	-	No. 3
3.55 x 2.8	M 4.5	M 3.5	No. 10-24	No. 6-32	No. 10-32	No. 6-40	3/16"-24	-	3/16"-32	-	No. 2	No. 4
4 x 3.15	M 5	M 4	No. 12-24	-	No. 12-28	-	-	-	7/32"-28	-	No. 1	-
4.5 x 3.55	M 6	-	1/4"-20	No. 8-32	1/4"-28	No. 3-36	1/4"-20	-	1/4"-26	-	No. 0	No. 3
5 x 4	-	M 5	-	No. 10-24	-	No. 10-32	-	3/16"-24	-	3/16"-32	-	No. 2
5.6 x 4.5	-	-	-	No. 12-24	-	No. 12-28	-	-	9/32"-26	7/32"-28	-	No. 1
6.3 x 5	M 8	M 6	5/16"-18	1/4"-20	5/16"-24	1/4"-28	5/16"-18	1/4"-20	5/16"-22	1/4"-26	-	No. 0
7.1 x 5.6	-	-	3/8"-16	-	3/8"-24	-	3/8"-16	-	3/8"-20	9/32"-36	-	-
8 x 6.3	M 10	M 8	7/16"-14	5/16"-18	7/16"-20	-	7/16"-14	5/16"-18	7/16"-18	5/16"-22	-	-
9 x 7.1	M 12	-	1/2"-13	-	1/2"-20	-	1/2"-12	-	1/2"-12	-	-	-
10 x 8	-	M 10	-	3/8"-16	-	3/8"-24	-	3/8"-16	-	3/8"-20	-	-
11.2 x 9	M 14	-	9/16"-12	-	9/16"-18	-	9/16"-12	-	9/16"-16	-	-	-
12.5 x 10	M 16	-	5/8"-11	-	5/8"-18	-	5/8"-11	-	3/8"-14	-	-	-
14 x 11.2	M 18	-	3/4"-10	-	3/4"-16	-	11/16"-11	-	11/16"-14	-	-	-
	M 20	-	-	-	-	-	3/4"-10	-	3/4"-12	-	-	-
16 x 12.5	M 22	-	7/8"-9	-	7/8"-14	-	7/8"-9	-	7/8"-11	-	-	-
18 x 14	M 24	-	1"-8	-	1"-12	-	1"-8	-	1"-10	-	-	-
20 x 16	M 27	-	1 1/8"-7	-	1 1/8"-12	-	1 1/8"-7	-	1 1/8"-9	-	-	-
	M 30	-	-	-	-	-	-	-	-	-	-	-
22.4 x 18	M 33	-	1 1/4"-4	-	1 1/4"-12	-	1 1/4"-7	-	1 1/4"-9	-	-	-
25 x 20	M 36	-	1 3/8"-6	-	1 3/8"-12	-	-	-	1 3/8"-8	-	-	-
28 x 22.4	M 39	-	1 1/2"-6	-	1 1/2"-12	-	1 1/2"-6	-	1 1/2"-8	-	-	-
	M 42	-	-	-	-	-	-	-	1 5/8"-8	-	-	-
31.5 x 25	M 45	-	1 3/4"-5	-	-	-	1 3/4"-5	-	1 3/4"-7	-	-	-
	M 48	-	-	-	-	-	-	-	-	-	-	-

Tap Shank Dimensions DIN Standards

Dimension Dia. x Square	DIN 352	DIN 353	DIN 371	DIN 374	DIN 376	DIN 2182	DIN 2183
3.5 x 2.7	M 3	-	M 3	M 5	M 5	1/8"	-
4 x 3	M 4	-	M 3.5	-	-	-	-
4.5 x 3.4	M 4	-	M 4	M 6	M 6	5/32"	1/4"
6 x 4.9	M 5	-	M 5	-	-	7/32"	-
	M 6	-	M 6	-	-	-	-
	M 8	-	-	M 8	M 8	-	-
7 x 5.5	M 10	G 1/8"	-	M 10	M 10	1/4"	3/8"
8 x 6.2	-	-	M 8	-	-	5/16"	7/16"
9 x 7	M 12	-	-	M 12	M 12	3/8"	1/2"
10 x 8	-	-	M 10	-	-	-	-
11 x 9	M 14	G 1/4"	-	M 14	M 14	-	9/16"
12 x 9	M 16	G 3/8"	-	M 16	M 16	-	5/8"
14 x 11	M 18	-	-	M 18	M 18	-	11/16"
16 x 12	M 20	G 1/2"	-	M 20	M 20	-	13/16"
18 x 14.5	M 22	G 5/8:	-	M 22	M 22	-	7/8"
	M 24	-	-	M 24	M 24	-	15/16"
20 x 16	M 27	G 3/4"	-	M 27	M 27	-	1"
22 x 18	M 30	G 7/8"	-	M 30	M 30	-	1 1/8"
25 x 20	M 33	G 1"	-	M 33	M 33	-	1 1/4"
28 x 22	M 36	G 1 1/8"	-	M 36	M 36	-	1 3/8"
32 x 24	M 39	G 1 1/8"	-	M 39	M 39	-	1 1/2"
	M 42	-	-	M 42	M 42	-	1 5/8"
36 x 29	M 45	G 3/8"	-	M 45	M 45	-	1 3/4"
	M 48	G 1 1/2"	-	M 48	M 48	-	1 7/8"
	-	G 1 3/4"	-	-	-	-	-
	-	G 2"	-	-	-	-	-

Note: All Dimensions are in mm
Continued...

Tap Shank Dimensions (JIS Standards)

Dimension in mm. Dia. x Square		Tap Size
3.00	2.50	M 1, M 2.6
4.00	3.00	M 3, M 3.5
4.00	3.20	M 3, M 3.5
5.00	4.00	M 4, M 4.5
5.50	4.50	M 5, M 5.5
6.00	4.50	M 6, 1/4"UNC
6.10	5.00	5/16"UNC
6.20	5.00	M 7, M 8
7.00	5.50	M 9, M 10, 3/8"UNC
8.00	6.00	M 11, 7/16"UNC, 1/8"P
8.00	6.20	M 11, 1/8"BSP
8.50	6.50	M 12
9.00	7.00	1/2"UNC
9.50	7.00	M 13
10.50	8.00	M 14, M 15, 9/16"UNC
11.00	9.00	1/4"P
12.00	9.00	5/8"UNC
12.50	10.00	M 16
13.00	10.00	M 17
14.00	11.00	M 18, 3/4"UNC, 3/8"P
15.00	12.00	M 20
17.00	13.00	M 22, 7/8"UNC
18.00	14.00	1/2"P
19.00	15.00	M 24, M 25, 5/8"P
20.00	15.00	M 26, M 27, 1"UNC
21.00	17.00	M 28
22.00	17.00	1 1/8"UNC
23.00	17.00	M 30, 3/4"P
24.00	19.00	M 32, 7/8"UNC
25.00	19.00	M 33
26.00	21.00	M 34, M 35 1"P
28.00	21.00	M 36, M 38 1 1/8"P
30.00	23.00	M 39, M 40
32.00	26.00	M 42, 1 1/4"P
35.00	26.00	M 45, 1 3/8"P
38.00	29.00	M 48, 1 1/2"P
40.00	32.00	M 52, M 56 & 1 7/8"UNC, 2"UNC

Tap Shank Dimensions ANSI (US Standards)

Dimension in Inch. Dia. x Square		Metric Conversions		Tap Size
0.141	0.110	3.59	2.80	1/8" No.6
0.168	0.131	4.27	3.33	5/32" No.8
0.194	0.152	4.93	3.87	3/16" No. 10
0.220	0.165	5.59	4.20	No. 12
0.255	0.191	6.48	4.86	1/4" No. 14
0.313	0.234	7.94	5.95	1/16"Ps 1/8"Ps
0.318	0.238	8.08	6.05	5/16" 3/8"
0.323	0.242	8.21	6.15	5/16" 7/16"
0.367	0.275	9.33	6.99	1/2"
0.381	0.286	9.68	7.27	3/8"
0.429	0.322	10.90	8.18	9/16"
0.438	0.328	11.12	8.34	1/8"PLs
0.480	0.360	12.20	9.15	5/8"
0.542	0.406	13.77	10.31	11/16"
0.563	0.421	14.29	10.70	1/4"Ps
0.590	0.442	14.99	11.23	3/4"
0.652	0.489	16.57	12.43	M 20, 13/16"
0.688	0.515	17.47	13.09	1/2" Ps
0.697	0.523	17.71	13.29	7/8"
0.700	0.531	17.78	13.49	3/8"Ps
0.760	0.570	19.31	14.48	M 24, 15/16"
0.800	0.600	20.32	15.24	1"
0.896	0.672	22.76	17.07	1 1/8"
0.906	0.679	23.02	17.25	3/4"P
1.021	0.766	25.94	19.46	1 1/4"
1.108	0.831	28.15	21.11	1 3/8"
1.125	0.843	28.58	21.42	1"P
1.233	0.925	31.32	23.50	1 1/2"
1.313	0.984	33.34	25.00	1 3/4"P
1.430	1.072	36.33	27.23	1 3/4"
1.500	1.125	38.10	28.58	1 1/2"P
1.644	1.233	41.76	31.32	2"

Note: All Dimensions are in mm

Recommended Torque Values

For Safety Clutch adjustment For Tapping & Cold Forming (Rolling)

For material upto 1000 N/mm²

Torque Setting Nm	Threads										Torque Setting Nm
	Metric	Whitworth BSW	BSP Whitworth Pipe	BSF	BSP Taper	BA	PG	NPT Taper	UNC	UNF	
0.5	M3	-	-	-	-	No. 7	-	-	-	-	0.5
0.6	-	-	-	-	-	No. 6	-	-	No. 3	No. 4	0.6
0.8	M 3.5	-	-	-	-	No. 5	-	-	No. 4	No. 5	0.8
1.0	-	1/8"	-	-	-	-	-	-	No. 5	-	1.0
1.2	-	-	-	-	-	No. 4	-	-	-	No. 6	1.2
1.6	M4	-	-	-	-	-	-	-	No. 6	No. 8	1.6
2.0	-	5/32"	-	-	-	No. 3	-	-	No. 8	-	2.0
2.5	M5	-	-	3/16"	-	No. 2	-	-	-	No. 10	2.5
3.0	-	-	-	-	-	-	-	-	-	No. 12	3.0
4.0	-	3/16"	-	7/32"	-	No. 1	-	-	No. 10	1/4"	4.0
5.0	M6	7/32"	-	1/4"	-	No. 0	-	-	No. 12	-	5.0
6.0	-	-	G 1/8"	9/32"	-	-	-	-	-	5/16"	6.0
8.0	-	1/4"	-	5/16"	-	-	-	-	1/4"	3/8"	8.0
10	M8	-	-	-	-	-	-	-	-	-	10
12	-	5/16"	-	3/8"	-	-	PG 7	-	5/16"	7/16"	12
16	-	-	-	-	-	-	-	-	-	1/2"	16
18	M10	3/8"	G 1/4"	7/16"	1/8"	-	-	-	3/8"	-	18
20	-	-	-	-	-	-	PG9	1/8"	-	-	20
22	-	-	-	-	-	-	PG11	-	-	9/16"	22
25	-	-	-	1/2"	-	-	PG 13.5	-	-	5/8"	25
28	M 12	7/16"	G 3/8"	-	-	-	PG 16	-	7/16"	-	28
32	-	-	-	9/16"	-	-	-	-	-	-	32
36	-	-	-	-	-	-	-	-	-	3/4"	36
40	-	-	-	5/8"	-	-	-	-	1/2"	-	40
45	M 14	1/2"	-	11/16"	-	-	PG 21	-	-	-	45
50	M 16	-	G 1/2"	-	1/4"	-	-	-	9/16"	-	50
56	-	-	G 5/8"	-	-	-	-	1/4"	-	7/8"	56
63	-	5/8"	-	-	3/8"	-	PG 29	-	5/8"	-	63
70	-	-	G 3/4"	3/4"	-0	-	-	3/8"	-	-	70
80	M 18	-	G 7/8"	13/16"	-	-	PG 36	-	-	-	80
90	M 20	3/4"	-	7/8"	-	-	PG 42	-	3/4"	1"	90
100	M22	-	-	-	-	-	PG 48	-	-	1 1/8"	100
110	-	-	-	-	-	-	-	-	-	1/4"	110
125	-	7/8"	-	1"	-	-	-	-	7/8"	1 3/8"	125
140	-	-	G 1"	-	-	-	-	-	-	1 1/2"	140
160	M24	-	G 1 1/8"	-	1/2"	-	-	1/2"	-	-	160
180	M 27	-	G 1 1/4"	1 1/8"	-	-	-	-	-	-	180
200	-	1"	G 1 3/8"	1 1/4"	3/4"	-	-	3/4"	1"	-	200
220	-	-	G 1 1/2"	-	-	-	-	-	-	-	220
240	-	-	G 1 3/4"	-	-	-	-	-	-	-	240
260	-	-	G 2"	1 3/8"	-	-	-	-	-	-	260
280	M 30	1 1/8"	-	-	-	-	-	-	1 1/8"	-	280
300	-	-	G 2 1/4"	1 1/2"	-	-	-	-	-	-	300
320	M 33	1 1/4"	-	1 5/8"	-	-	-	-	1 1/4"	-	320
340	-	-	G 2 3/4"	-	1"	-	-	1"	-	-	340
360	-	-	G 2 3/4"	-	-	-	-	-	-	-	360
400	-	-	G 3"	-	-	-	-	-	-	-	400
420	M 36	-	G 3 1/4"	-	-	-	-	-	-	-	420
450	-	-	G 3 1/2"	1 3/4"	1 1/4"	-	-	1 1/4"	-	-	450
480	M 39	1 3/8"	G 3 3/4"	-	-	-	-	-	1 3/8"	-	480
500	-	1 1/2"	G 4"	2"	-	-	-	-	1 1/2"	-	500
560	-	-	-	-	1 1/2"	-	-	1 1/2"	-	-	560
630	M 42	-	-	-	-	-	-	-	-	-	630
710	M 45	-	-	2 1/4"	2"	-	-	2"	-	-	710
800	-	1 5/8"	-	2 1/2"	-	-	-	-	-	-	800
900	M 48	1 3/4"	-	2 3/4"	-	-	-	-	1 3/4"	-	900

The given torque values are for tapping & cold forming operations. They pertain to material with a tensile strength of 1000 N/mm².

The torque values for tapping include a wear factor of 100%.

If necessary, these values can be increased by up to 20% for tapping & up to 50% for cold forming.

Note: All Dimensions are in mm

Continued...

Recommended Torque Values

For Safety Clutch adjustment For Tapping & Cold Forming (Rolling)

For material upto 1000 N/mm²

Torque Setting Nm	Threads										Torque Setting Nm
	Metric	Whitworth BSW	BSP Whitworth Pipe	BSF	BSP Taper	BA	PG	NPT Taper	UNC	UNF	
1000	M 52				2 1/2"						1000
1100											1100
1250	M 56	2"								2"	1250
1400				3"	3"				2 1/2"		1400
2000		2 1/4"							3"		2000
2200		2 1/2"									2200

The given torque values are for tapping & cold forming operations. They pertain to material with a tensile strength of 1000 N/mm². The torque values for tapping include a wear factor of 100%.

If necessary, these values can be increased by up to 20% for tapping & up to 50% for cold forming.

Note: All Dimensions are in mm

Pull Studs (PS)

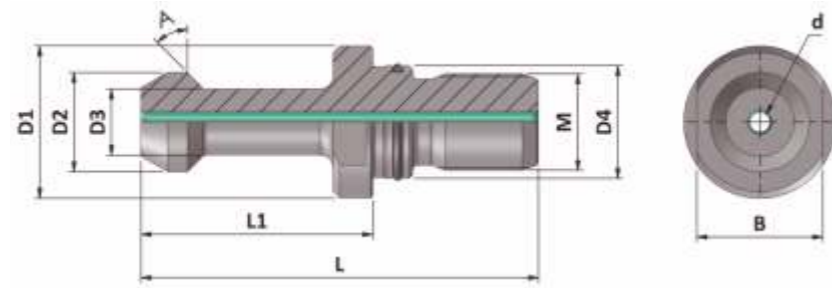

BT (MAS)

Item Name	Item Code	d	D1	D2	D3	D4	A	B	M	L	L1
PS BT30 45 DEG W/TC	S10195344311126	-	16.5	11	7	12.5	45	13	M12	43	23
PS BT30 60 DEG W/TC	S10195344312238	-	16.5	11	7	12.5	60	13	M12	43	23
PS BT30 90 DEG W/TC	S10195344313126	-	16.5	11	7	12.5	90	13	M12	43	23

PS BT40 45 DEG TC WITH O RING	S10195345311237	3	23	15	10	17	45	19	M16	60	35
PS BT40 45 DEG W/TC	S10195345311126	-	23	15	10	17	45	19	M16	60	35
PS BT40 45 DEG W/TC WITH O RING	S10195345311238	-	23	15	10	17	45	19	M16	60	35
PS BT40 60 DEG TC WITH O RING	S10195345312237	3	23	15	10	17	60	19	M16	60	35
PS BT40 60 DEG W/TC	S10195345312126	-	23	15	10	17	60	19	M16	60	35
PS BT40 60 DEG W/TC WITH O RING	S10195345312238	-	23	15	10	17	60	19	M16	60	35
PS BT40 90 DEG TC WITH O RING	S10195345313237	3	23	15	10	17	90	19	M16	60	35
PS BT40 90 DEG W/TC	S10195345313126	-	23	15	10	17	90	19	M16	60	35
PS BT40 90 DEG W/TC WITH O RING	S10195345313238	-	23	15	10	17	90	19	M16	60	35

PS BT50 45 DEG TC WITH O RING	S10195346311237	7	38	23	17	25	45	30	M24	85	45
PS BT50 45 DEG W/TC	S10195346311126	-	38	23	17	25	45	30	M24	85	45
PS BT50 45 DEG W/TC WITH O RING	S10195346311238	-	38	23	17	25	45	30	M24	85	45
PS BT50 60 DEG TC WITH O RING	S10195346312237	7	38	23	17	25	60	30	M24	85	45
PS BT50 60 DEG W/TC	S10195346312126	-	38	23	17	25	60	30	M24	85	45
PS BT50 60 DEG W/TC WITH O RING	S10195346312238	-	38	23	17	25	60	30	M24	85	45
PS BT50 90 DEG TC WITH O RING	S10195346313237	7	38	23	17	25	90	30	M24	85	45
PS BT50 90 DEG W/TC	S10195346313126	-	38	23	17	25	90	30	M24	85	45
PS BT50 90 DEG W/TC WITH O RING	S10195346313238	-	38	23	17	25	90	30	M24	85	45

Pull Studs (PS)

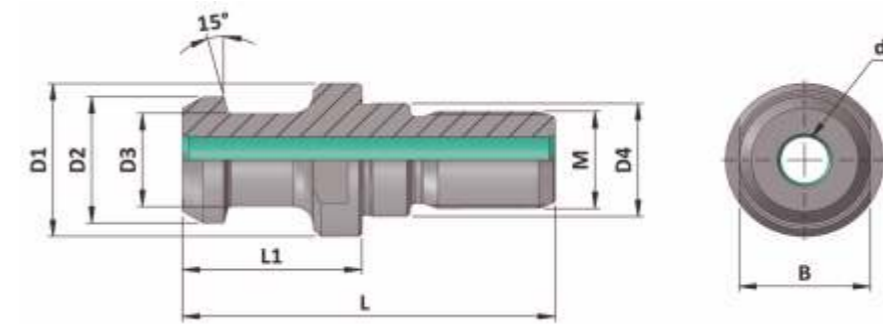

ISO 7388 A Pull Studs (PS)

Item Name	Item Code	d	D1	D2	D3	D4	B	M	L	L1
PS ISO40 A ISO7388 TC	S10195351309125	7.3	23	19	14	17	19	M16	54	26
PS ISO40 A ISO7388 W/TC	S10195351309126	-	23	19	14	17	19	M16	54	26

PS ISO50 A ISO7388 TC	S10195352309125	11.5	36	28	21	25	30	M24	74	34
PS ISO50 A ISO7388 W/TC	S10195352309126	-	36	28	21	25	30	M24	74	34

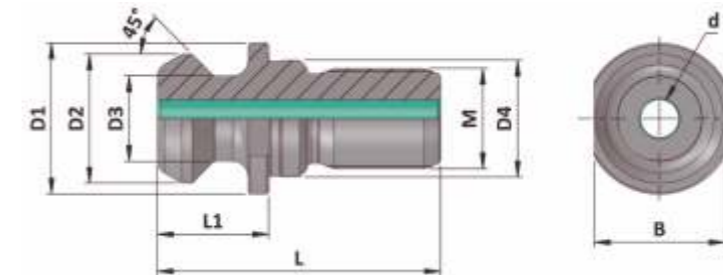

ISO 7388 B Pull Studs (PS)

Item Name	Item Code	d	D1	D2	D3	D4	B	M	L	L1
PS ISO40 B ISO7388 TC	S10195351310125	7.3	22.5	18.8	12.95	17	19	M16	44.5	16.4
PS ISO40 B ISO7388 W/TC	S10195351310126	-	22.5	18.8	12.95	17	19	M16	44.5	16.4

PS ISO50 B ISO7388 TC	S10195352310125	11.5	37	29.1	19.6	25	30	M24	65.5	25.5
PS ISO50 B ISO7388 W/TC	S10195352310126	-	37	29.1	19.6	25	30	M24	65.5	25.5

Pull Studs (PS)

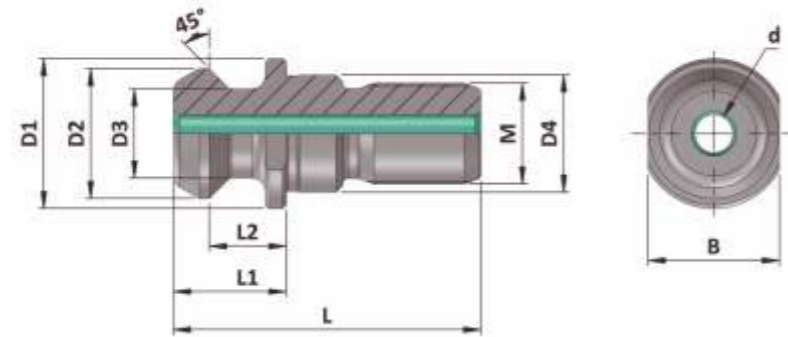

Mazak Pull Studs (PS)

Item Name	Item Code	d	D1	D2	D3	D4	B	M	L	L1	L2
PS MAZAK BT40 TC	S10195377320125	7	22	18.8	12.45	17	19	M16	44.10	19.10	14
PS MAZAK BT40 W/TC	S10195377320126	-	22	18.8	12.45	17	19	M16	44.10	19.10	14

PS MAZAK SK40 TC	S10195377321125	7	22	18.8	12.45	17	19	M16	41.10	16.10	11
PS MAZAK SK40 W/TC	S10195377321126	-	22	18.8	12.45	17	19	M16	41.10	16.10	11

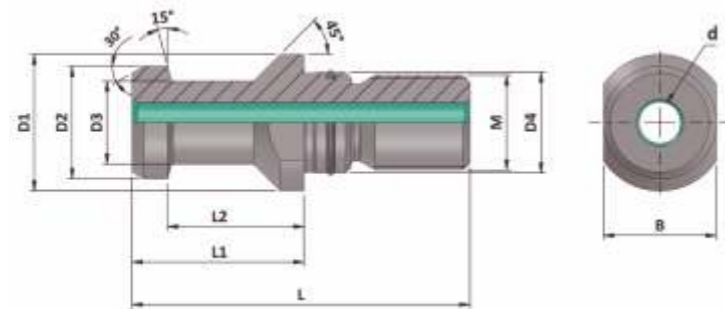

SK (DIN 69872-A) Pull Studs (PS)

Item Name	Item Code	d	D1	D2	D3	D4	B	M	L	L1	L2
PS SK30 A DIN 69872 W/TC WITH O RING	S10195610531238	-	17	13	9	13	14	M12	44	24	19

PS SK40 A DIN 69872 TC WITH O RING	S10195347531237	7	23	19	14	17	19	M16	54	26	20
PS SK40 A DIN 69872 W/TC WITH O RING	S10195347307238	-	23	19	14	17	19	M16	54	26	20

PS SK50 A DIN 69872 TC WITH O RING	S10195348531237	11.5	36	28	21	25	30	M24	74	34	25
PS SK50 A DIN 69872 W/TC WITH O RING	S10195348307238	-	36	28	21	25	30	M24	74	34	25



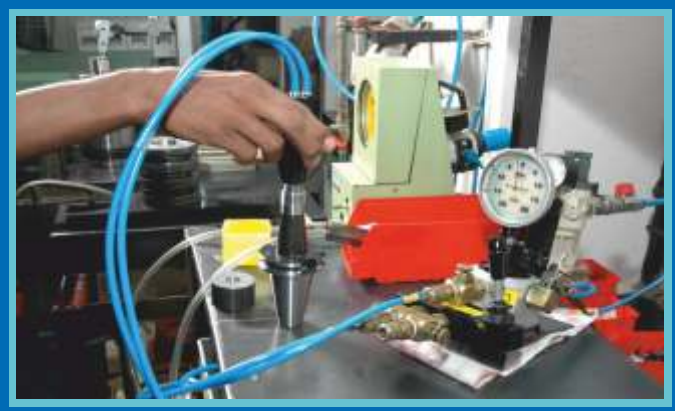

The logo for Sigma Toolings is a white triangle pointing to the right, set against a teal background. Inside the triangle, the word "SIGMA" is written in a bold, teal, sans-serif font, and the word "TOOLINGS" is written below it in a bold, black, sans-serif font.

SIGMA
TOOLINGS

Sigma Toolings India Pvt Ltd

Office: Gut No. 254, Borhadewadi,
Dehu-Alandi Road, Moshi, Pune-412 105 (M.S)

Factory: G-39/20, MIDC Waluj, Aurangabad.

Call: +91 92722 22511 / +91 76206 05260

Email: pune@sigmatoolings.com /
info@sigmatoolings.com