





SIGMA
TOOLINGS

**PRECISION
HYDRAULIC
EXPANSION
CHUCKS**







INDEX

Sr. No.	Contents		Page No.
1	<p>Precision Hydraulic Expansion Chucks HSK Series</p> <ul style="list-style-type: none"> • Technical Information HSK-A (DIN 69893-1) • HSK-A (DIN 69893-1) Heavy Duty • HSK-A (DIN 69893-1) Standard Series • Technical Information HSK-C (DIN 69893-1) • HSK-C (DIN 69893-1) Standard Series • Technical Information HSK-E (DIN 69893-5) • HSK-E (DIN 69893-5) Standard Series • Technical Information HSK-F (DIN 69893-6) • HSK-F (DIN 69893-6) Standard Series 		04-17
2	<p>Precision Hydraulic Expansion Chucks BT(MAS 403) DIN ISO 7388 - 2</p> <ul style="list-style-type: none"> • Technical Information • Heavy Duty • Standard Series • Short GP 		18-24
3	<p>Precision Hydraulic Expansion Chucks BBT(MAS 403) DIN ISO 7388 - 2</p> <ul style="list-style-type: none"> • Technical Information • Heavy Duty • Standard Series • Short GP 		25-32
4	<p>Precision Hydraulic Expansion Chucks SK (DIN 69871) DIN ISO 7388 - 1</p> <ul style="list-style-type: none"> • Technical Information • Heavy Duty • Standard Series • For Tool & Cutter CNC Grinding Machine • Short GP 		33-39

Precision Hydraulic Expansion Chucks

INDEX

Sr. No.	Contents		Page No.
5	Precision Hydraulic Expansion Chucks CAT (ANSI B 5.50) : <ul style="list-style-type: none"> • Technical Information • Heavy Duty • Standard Series • Short GP 		40-45
6	Precision Hydraulic Chucks <ul style="list-style-type: none"> • Cylindrical Shank • VDI Shank • ER Type 		46-51
7	Reduction Sleeves Seal (RS Seal) For Hydraulic Expansion Chucks		52-53
8	Hydraulic Expansion Chuck KIT & Accessories		54
9	Technical Information		55-56

Declaration

The information in this catalogue is believed to be correct. Sigma Toolings India Pvt. Ltd., however, assumes no responsibility for any, errors, inaccuracies or omissions that may appear in this catalogue. Information in this catalogue is subject to change without notice and should not be taken as a commitments by Sigma Tooling India Pvt. Ltd. or its subsidiaries.

Sigma Toolings India Pvt. Ltd.
Aurangabad - MH (INDIA)

◆ Features :

- “Sigma” Hydraulic Expansion Chuck is a very precision & high technology product.
- Maintenance free design & easy to use, along with Reduction Sleeves (RS Seal).
- Best suitable for Drilling, Reaming & Milling operations.
- Most recommended for Die & Mould making industries & machining of precision automobile components.
- Useful for Ductile material also.
- The tool runs true less than 5 micron on 3D, hence the tool life & machinability increases drastically. you can achieve the highest accuracy & repeatability & high transferable torque.
- Best operating temperature (20°C/40°C).

◆ Available in mountings :

- HSK - A (DIN 69893 - 1)
- HSK - C (DIN 69893 - 1)
- HSK - E (DIN 69893 - 5)
- HSK - F (DIN 69893 - 6)
- BT(MAS 403) (DIN ISO 7388 -2)
- BBT (MAS 403) (Face & Tapper Contact)
- SK (DIN 69871) (DIN ISO 7388 - 1)
- CAT (ANSI - B 5.50)
- Cylindrical Shank
- VDI Shank
- ER Type

◆ Capacity

Heavy Duty:

- HC12S
 - HC20S
 - HC32S
- Standard Series from Sizes:
- HC 06 TO HC 32

◆ Balancing :

- Balanced to 2.5G 25000 RPM.



HSK-A (DIN 69893-1)

HSK-C (DIN 69893-1)

HSK-E (DIN 69893-5)

HSK-F (DIN 69893-6)



HSK-A (DIN 69893-1) Form A : Technical Information

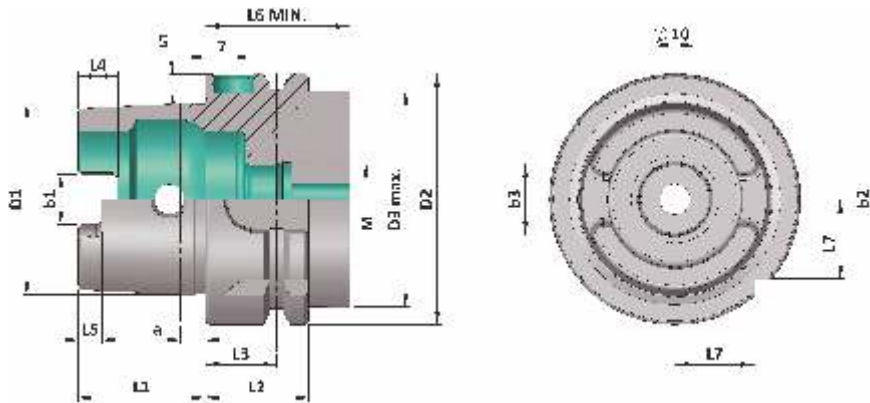

HSK-A	D1	D2	D3	a	b1	b2	b3	M	L1	L2	L3	L4	L5	L6	L7
32	24	32	26	3.20	7.05	7	9	M10x1	16	20	16	5	3	35	9.50
40	30	40	34	4	8.05	9	11	M12x1	20	20	16	6	3.50	35	12
50	38	50	42	5	10.54	12	14	M16x1	25	26	18	7.50	4.50	42	15.50
63	48	63	53	6.30	12.54	16	18	M18x1	32	26	18	10	6	42	20
80	60	80	68	8	16.04	18	20	M20x1.5	40	26	18	12	8	42	25
100	75	100	88	10	20.02	20	22	M24x1.5	50	29	20	15	10	45	31.50
125	95	125	111	12.50	25.02	25	28	M30x1.5	63	29	20	19	12	45	39.50

Material :- Case hardened steel, tensile strength in the core min. 950 N/mm²

Execution :- Case hardened to HRC 58 ± 2, Case Depth 0.8 mm., Silver finish.

Accuracy :- Taper Angle Class AT 3

HSK-A (DIN 69893 - 1) Hydraulic Expansion Chuck

HEAVY DUTY

Maximum Run out of the Internal Dia with respect to the External Taper 0.003 mm

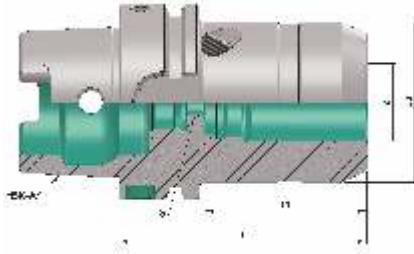

HSK-A (DIN 69893 - 1) Hydraulic Expansion Chuck

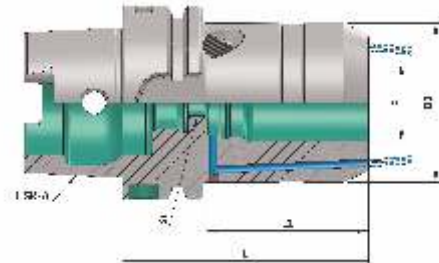

HSK-A (DIN 69893 - 1) Hydraulic Expansion Chuck (FCC)

HSK-A (DIN 69893 - 1) Hydraulic Expansion Chuck

(Balanced to 2.5 G 25000 RPM)

Item Name	Item Code	HSK-A	d	D1	G	L	L1
HSK-A 50 HC12S 085 2.5G 25000 SL	S10306629135283	50	12	42	M10	85	40
HSK-A 50 HC20S 090 2.5G 25000 SL	S10306168140283	50	20	50	M16	90	42
HSK-A 63 HC12S 080 2.5G 25000 SL	S10305629131283	63	12	42	M10	80	40
HSK-A 63 HC20S 080 2.5G 25000 SL	S10305168131283	63	20	50	M16	80	42
HSK-A 100 HC12S 095 2.5G 25000 SL	S10168629145283	100	12	42	M10	95	40
HSK-A 100 HC20S 090 2.5G 25000 SL	S10168168140283	100	20	50	M16	90	42
HSK-A 100 HC32S 110 2.5G 25000 SL	S10168272156283	100	32	72	M16	110	55

HSK-A (DIN 69893 - 1) Hydraulic Expansion Chuck (FCC)

(Balanced to 2.5 G 25000 RPM)

Item Name	Item Code	HSK-A	d	D1	G	L	L1
HSK-A 50 HC12S 085 FCC 2.5G 25000 SL	S10166629135227	50	12	42	M10	85	40
HSK-A 50 HC20S 090 FCC 2.5G 25000 SL	S10166168141124	50	20	50	M16	90	42
HSK-A 63 HC12S 080 FCC 2.5G 25000 SL	S10305629135227	63	12	42	M10	80	40
HSK-A 63 HC20S 080 FCC 2.5G 25000 SL	S10167168141124	63	20	50	M16	80	42
HSK-A 100 HC12S 095 FCC 2.5G 25000 SL	S10168629131255	100	12	42	M10	95	40
HSK-A 100 HC20S 090 FCC 2.5G 25000 SL	S10168168152124	100	20	50	M16	90	42
HSK-A 100 HC32S 110 FCC 2.5G 25000 SL	S10168272156227	100	32	72	M16	110	55

Accessories:



Reduction Sleeve Seal
(RS Seal) Ref. Page No.52-53

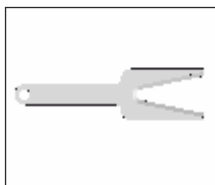

Spanner HC
Ref. Page No.54

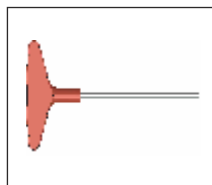

Key HC 5mm
Ref. Page No.54

Note: All Dimensions are in mm

Maximum Run out of the Internal Dia with respect to the External Taper 0.003 mm

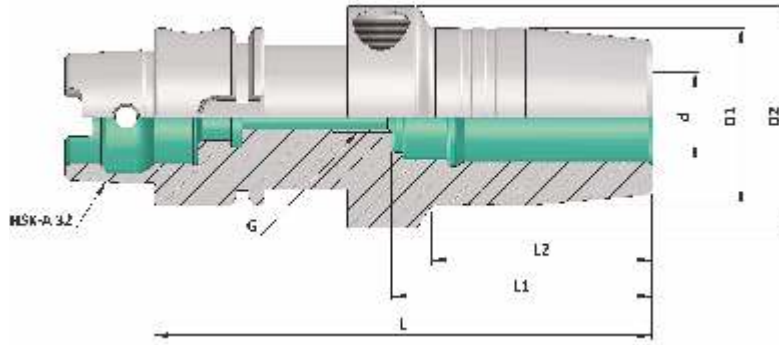

HSK-A (DIN 69893 - 1) Hydraulic Expansion Chuck

(Balanced to 2.5 G 25000 RPM)

Item Name	Item Code	HSK-A	d	D1	D2	G	L	L1	L2
HSK-A 32 HC06 080 2.5G 25000 SL	S10319642131283	32	6	26	40	M5	80	37	29
HSK-A 32 HC08 080 2.5G 25000 SL	S10319643131283	32	8	28	40	M6	80	37	29
HSK-A 32 HC10 085 2.5G 25000 SL	S10319644135283	32	10	30	40	M6	85	41	35
HSK-A 32 HC12 090 2.5G 25000 SL	S10319636140283	32	12	32	40	M6	90	46	40

Accessories:



Reduction Sleeve Seal
 (RS Seal) Ref. Page No.52-53

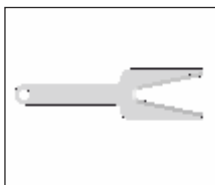

Spanner HC
 Ref. Page No.54

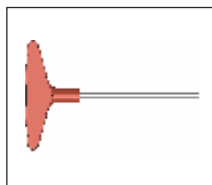

Key HC 5mm
 Ref. Page No.54

Note: All Dimensions are in mm

HSK-A (DIN 69893 - 1) Hydraulic Expansion Chuck

Maximum Run out of the Internal Dia with respect to the External Taper 0.003 mm

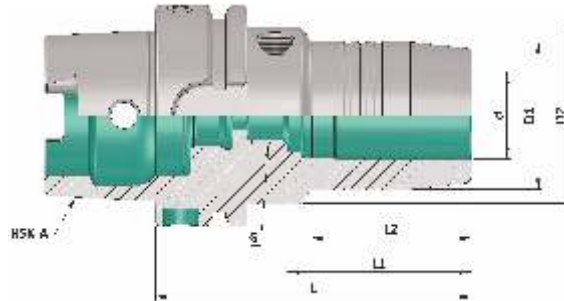

HSK-A (DIN 69893 - 1) Hydraulic Expansion Chuck

(Balanced to 2.5 G 25000 RPM)

Item Name	Item Code	HSK-A	d	D1	D2	G	L	L1	L2
HSK-A 40 HC06 070 2.5G 25000 SL	S10165642125283	40	6	26	33.5	M5	70	37	36
HSK-A 40 HC08 070 2.5G 25000 SL	S10165643125283	40	8	28	33.5	M6	70	37	36
HSK-A 40 HC10 075 2.5G 25000 SL	S10165644127283	40	10	30	33.5	M6	75	41	42
HSK-A 40 HC12 080 2.5G 25000 SL	S10165636131283	40	12	32	33.5	M6	80	46	48
HSK-A 50 HC06 070 2.5G 25000 SL	S10306642125281	50	6	26	40	M5	70	37	28
HSK-A 50 HC08 070 2.5G 25000 SL	S10306643125281	50	8	28	40	M6	70	37	28
HSK-A 50 HC10 075 2.5G 25000 SL	S10306644127281	50	10	30	40	M8	75	41	34
HSK-A 50 HC12 085 2.5G 25000 SL	S10306636135275	50	12	32	40	M10	85	46	44
HSK-A 50 HC14 085 2.5G 25000 SL	S10306645135281	50	14	34	40	M10	85	46	44
HSK-A 50 HC16 090 2.5G 25000 SL	S10306646140281	50	16	38	53	M12	90	49	30
HSK-A 50 HC18 090 2.5G 25000 SL	S10306647140281	50	18	40	53	M12	90	49	30
HSK-A 50 HC20 090 2.5G 25000 SL	S10306637140275	50	20	42	57	M16	90	51	29

Accessories:



Reduction Sleeve Seal
(RS Seal) Ref. Page No.52-53

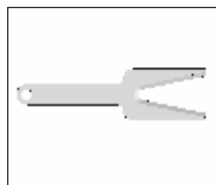

Spanner HC
Ref. Page No.54

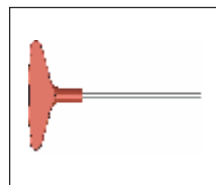

Key HC 5mm
Ref. Page No.54

Note: All Dimensions are in mm

Maximum Run out of the Internal Dia with respect to the External Taper 0.003 mm

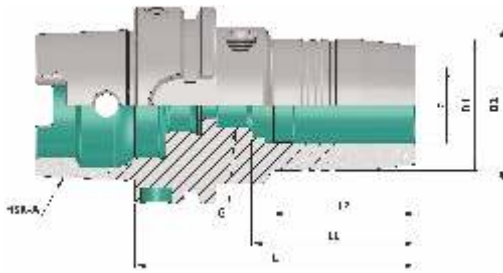

Standard GP

HSK-A (DIN 69893 - 1) Hydraulic Expansion Chuck

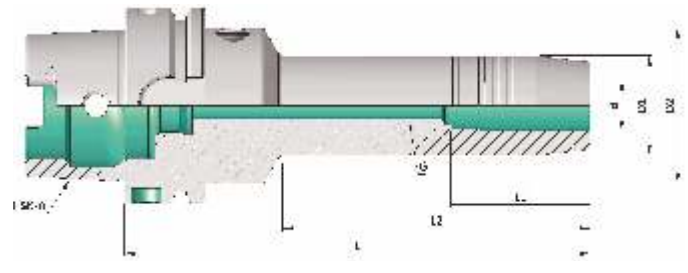

Long GP

HSK-A (DIN 69893 - 1) Hydraulic Expansion Chuck

HSK-A (DIN 69893 - 1) Hydraulic Expansion Chuck

(Balanced to 2.5 G 25000 RPM)

Item Name	Item Code	HSK-A	d	D1	D2	G	L	L1	L2
HSK-A 63 HC06 070 2.5G 25000 SL	S10305642125281	63	6	26	50	M5	70	37	24
HSK-A 63 HC06 120 2.5G 25000 SL	S10305642162283	63	6	26	50	M5	120	37	73
HSK-A 63 HC06 150 2.5G 25000 SL	S10305642173281	63	6	26	50	M5	150	37	103
HSK-A 63 HC06 200 2.5G 25000 SL	S10305642239281	63	6	26	50	M5	200	37	153
HSK-A 63 HC08 070 2.5G 25000 SL	S10305643125281	63	8	28	50	M6	70	37	25
HSK-A 63 HC08 120 2.5G 25000 SL	S10305643162283	63	8	28	50	M6	120	37	74
HSK-A 63 HC08 150 2.5G 25000 SL	S10305643173281	63	8	28	50	M6	150	37	104
HSK-A 63 HC08 200 2.5G 25000 SL	S10305643239281	63	8	28	50	M6	200	37	154
HSK-A 63 HC10 080 2.5G 25000 SL	S10305644131281	63	10	30	50	M8	80	41	35
HSK-A 63 HC10 120 2.5G 25000 SL	S10305644162283	63	10	30	50	M8	120	41	74
HSK-A 63 HC10 150 2.5G 25000 SL	S10305644173281	63	10	30	50	M8	150	41	104
HSK-A 63 HC10 200 2.5G 25000 SL	S10305644239281	63	10	30	50	M8	200	41	154
HSK-A 63 HC12 085 2.5G 25000 SL	S10305636135275	63	12	32	50	M10	85	46	40
HSK-A 63 HC12 120 2.5G 25000 SL	S10305636162283	63	12	32	50	M10	120	46	75
HSK-A 63 HC12 150 2.5G 25000 SL	S10305636173275	63	12	32	50	M10	150	46	105
HSK-A 63 HC12 200 2.5G 25000 SL	S10305636239275	63	12	32	50	M10	200	46	155
HSK-A 63 HC14 085 2.5G 25000 SL	S10305645135281	63	14	34	50	M10	85	46	40
HSK-A 63 HC14 120 2.5G 25000 SL	S10305645162283	63	14	34	50	M10	120	46	75
HSK-A 63 HC14 150 2.5G 25000 SL	S10305645173281	63	14	34	50	M10	150	46	105
HSK-A 63 HC14 200 2.5G 25000 SL	S10305645239281	63	14	34	50	M10	200	46	155
HSK-A 63 HC16 090 2.5G 25000 SL	S10305646140281	63	16	38	50	M12	90	49	46
HSK-A 63 HC16 120 2.5G 25000 SL	S10305646162283	63	16	38	50	M12	120	49	76
HSK-A 63 HC16 150 2.5G 25000 SL	S10305646173281	63	16	38	50	M12	150	49	106
HSK-A 63 HC16 200 2.5G 25000 SL	S10305646239281	63	16	38	50	M12	200	49	156
HSK-A 63 HC18 090 2.5G 25000 SL	S10305647140281	63	18	40	50	M12	90	49	47
HSK-A 63 HC18 120 2.5G 25000 SL	S10305647162283	63	18	40	50	M12	120	49	77
HSK-A 63 HC18 150 2.5G 25000 SL	S10305647173281	63	18	40	50	M12	150	49	107
HSK-A 63 HC18 200 2.5G 25000 SL	S10305647239281	63	18	40	50	M12	200	49	157
HSK-A 63 HC20 090 2.5G 25000 SL	S10305637140275	63	20	42	50	M16	90	51	48
HSK-A 63 HC20 120 2.5G 25000 SL	S10305637162283	63	20	42	50	M16	120	51	78
HSK-A 63 HC20 150 2.5G 25000 SL	S10305637173275	63	20	42	50	M16	150	51	108
HSK-A 63 HC20 200 2.5G 25000 SL	S10305637239275	63	20	42	50	M16	200	51	158
HSK-A 63 HC25 120 2.5G 25000 SL	S10305648162281	63	25	57	53	M16	120	57	63
HSK-A 63 HC32 125 2.5G 25000 SL	S10305638164275	63	32	63	59	M16	125	61	61

HSK-A (DIN 69893 - 1) Hydraulic Expansion Chuck

Maximum Run out of the Internal Dia with respect to the External Taper 0.003 mm

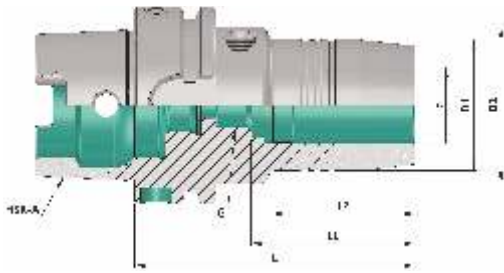

Standard GP

HSK-A (DIN 69893 - 1) Hydraulic Expansion Chuck

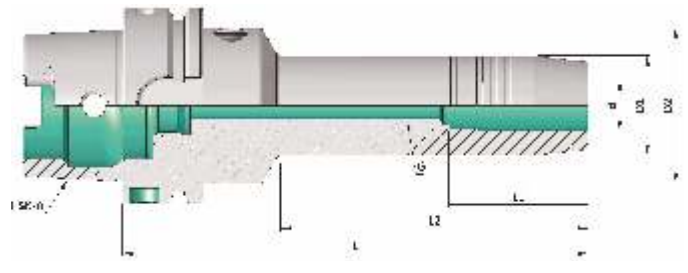

Long GP

HSK-A (DIN 69893 - 1) Hydraulic Expansion Chuck

HSK-A (DIN 69893 - 1) Hydraulic Expansion Chuck

(Balanced to 2.5 G 25000 RPM)

Item Name	Item Code	HSK-A	d	D1	D2	G	L	L1	L2
HSK-A 63 HC1/4" - 70 2.5G 25000 SL	S10305649622283	63	1/4"	26	50	M5	70	37	24
HSK-A 63 HC3/8" - 80 2.5G 25000 SL	S10305650623283	63	3/8"	30	50	M8	80	41	35
HSK-A 63 HC1/2" - 85 2.5G 25000 SL	S10305652624283	63	1/2"	32	50	M10	85	46	40
HSK-A 63 HC3/4" - 90 2.5G 25000 SL	S10305653628283	63	3/4"	42	50	M16	90	51	48
HSK-A 63 HC 1.0" - 120 2.5G 25000 SL	S10305656625283	63	1.0"	57	63	M16	120	57	59
HSK-A 63 HC1-1/4" - 125 2.5G 25000 SL	S10305655626283	63	1-1/4"	64	75	M16	125	61	65
HSK-A 80 HC06 070 2.5G 25000 SL	S10320642125283	80	6	26	50	M5	70	37	24
HSK-A 80 HC08 070 2.5G 25000 SL	S10320643125283	80	8	28	50	M6	70	37	24
HSK-A 80 HC10 080 2.5G 25000 SL	S10320644131283	80	10	30	50	M8	80	41	35
HSK-A 80 HC12 085 2.5G 25000 SL	S10320636135283	80	12	32	50	M10	85	46	40
HSK-A 80 HC14 085 2.5G 25000 SL	S10320645135283	80	14	34	50	M10	85	46	40
HSK-A 80 HC16 095 2.5G 25000 SL	S10320646145283	80	16	38	50	M12	95	49	51
HSK-A 80 HC18 095 2.5G 25000 SL	S10320647145283	80	18	40	50	M12	95	49	51
HSK-A 80 HC20 095 2.5G 25000 SL	S10320637145283	80	20	42	50	M16	95	51	51
HSK-A 80 HC25 110 2.5G 25000 SL	S10320648156283	80	25	57	63	M16	110	57	65
HSK-A 80 HC32 125 2.5G 25000 SL	S10320638164283	80	32	63	63	M16	125	61	63

Accessories:



Reduction Sleeve Seal
(RS Seal) Ref. Page No.52-53

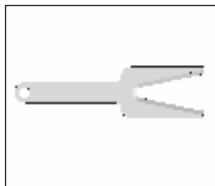

Spanner HC
Ref. Page No.54

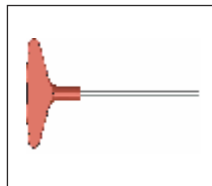

Key HC 5mm
Ref. Page No.54

Note: All Dimensions are in mm

**HSK-A (DIN 69893 - 1)
Hydraulic Expansion Chuck**

Maximum Run out of the Internal Dia with respect to the External Taper 0.003 mm

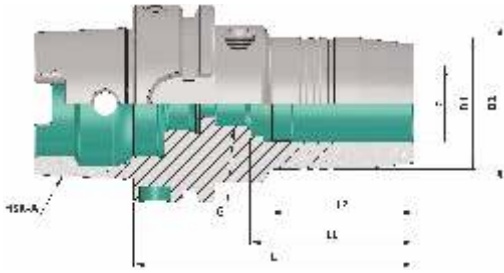

Standard GP

HSK-A (DIN 69893 - 1) Hydraulic Expansion Chuck

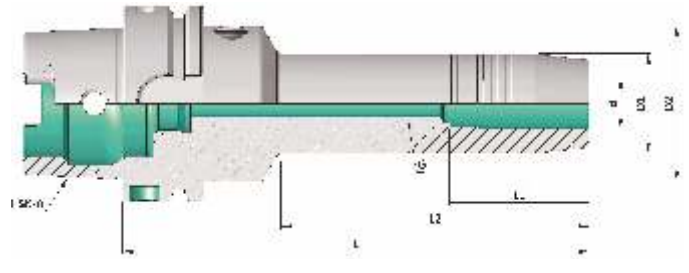

Long GP

HSK-A (DIN 69893 - 1) Hydraulic Expansion Chuck

HSK-A (DIN 69893 - 1) Hydraulic Expansion Chuck

(Balanced to 2.5 G 25000 RPM)

Item Name	Item Code	HSK-A	d	D1	D2	G	L	L1	L2
HSK-A 100 HC06 075 2.5G 25000 SL	S10168642127281	100	6	26	50	M5	75	37	26
HSK-A 100 HC06 150 2.5G 25000 SL	S10168642173281	100	6	26	50	M5	150	37	100
HSK-A 100 HC06 200 2.5G 25000 SL	S10168642239281	100	6	26	50	M5	200	37	150
HSK-A 100 HC08 075 2.5G 25000 SL	S10168643127281	100	8	28	50	M6	75	37	26
HSK-A 100 HC08 150 2.5G 25000 SL	S10168643173281	100	8	28	50	M6	150	37	100
HSK-A 100 HC08 200 2.5G 25000 SL	S10168643239281	100	8	28	50	M6	200	37	150
HSK-A 100 HC10 090 2.5G 25000 SL	S10168644140281	100	10	30	50	M8	90	41	42
HSK-A 100 HC10 150 2.5G 25000 SL	S10168644173281	100	10	30	50	M8	150	41	100
HSK-A 100 HC10 200 2.5G 25000 SL	S10168644239281	100	10	30	50	M8	200	41	150
HSK-A 100 HC12 095 2.5G 25000 SL	S10168636145275	100	12	32	50	M10	95	46	47
HSK-A 100 HC12 150 2.5G 25000 SL	S10168636173275	100	12	32	50	M10	150	46	100
HSK-A 100 HC12 200 2.5G 25000 SL	S10168636239275	100	12	32	50	M10	200	46	150
HSK-A 100 HC14 095 2.5G 25000 SL	S10168645145281	100	14	34	50	M10	95	46	47
HSK-A 100 HC14 150 2.5G 25000 SL	S10168645173281	100	14	34	50	M10	150	46	100
HSK-A 100 HC14 200 2.5G 25000 SL	S10168645239281	100	14	34	50	M10	200	46	150
HSK-A 100 HC16 100 2.5G 25000 SL	S10168646148281	100	16	38	50	M12	100	49	53
HSK-A 100 HC16 150 2.5G 25000 SL	S10168646173281	100	16	38	50	M12	150	49	100
HSK-A 100 HC16 200 2.5G 25000 SL	S10168646239281	100	16	38	50	M12	200	49	150
HSK-A 100 HC18 100 2.5G 25000 SL	S10168647148281	100	18	40	50	M12	100	49	53
HSK-A 100 HC18 150 2.5G 25000 SL	S10168647173281	100	18	40	50	M12	150	49	100
HSK-A 100 HC18 200 2.5G 25000 SL	S10168647239281	100	18	40	50	M12	200	49	150
HSK-A 100 HC20 105 2.5G 25000 SL	S10168637152275	100	20	42	50	M16	105	51	59
HSK-A 100 HC20 150 2.5G 25000 SL	S10168637173275	100	20	42	50	M16	150	51	100
HSK-A 100 HC20 200 2.5G 25000 SL	S10168637239275	100	20	42	50	M16	200	51	150
HSK-A 100 HC25 110 2.5G 25000 SL	S10168648159281	100	25	57	63	M16	110	57	62
HSK-A 100 HC32 110 2.5G 25000 SL	S10168638162275	100	32	63	67	M16	110	61	60
HSK-A 100 HC1-1/4" - 110 2.5G 25000 SL	S10168655627283	100	1.1/4"	64	75	M16	110	61	62

Accessories:



Reduction Sleeve Seal
(RS Seal) Ref. Page No.52-53



Spanner HC
Ref. Page No.54

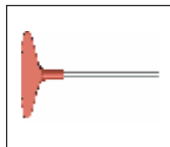

Key HC 5mm
Ref. Page No.54

Note: All Dimensions are in mm

HSK-E (DIN 69893 - 5) Form E : Technical Information

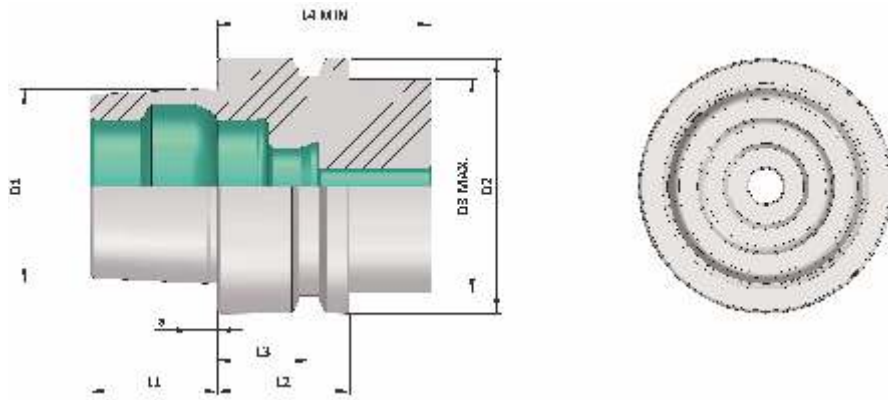

HSK-E	D1	D2	D3	a	L1	L2	L3	L4
40	30	40	34	4	20	20	16	35
50	38	50	42	5	25	26	18	42

Material :- Case hardened steel, tensile strength in the core min. 950 N/mm²

Execution :- Case hardened to HRC 58 ± 2, Case Depth 0.8 mm., Silver finish.

Accuracy :- Taper Angle Class AT 3

Maximum Run out of the Internal Dia with respect to the External Taper 0.003 mm

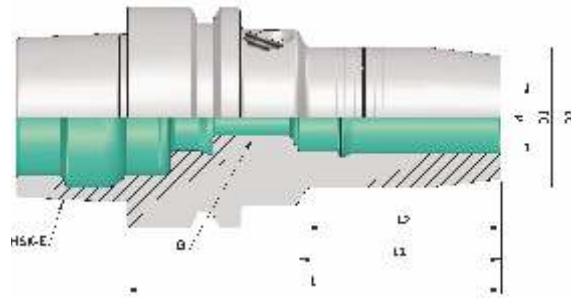

HSK-E (DIN 69893 - 5) Hydraulic Expansion Chuck

(Balanced to 2.5 G 25000 RPM)

Item Name	Item Code	HSK-E	d	D1	D2	G	L	L1	L2
HSK-E 40 HC06 070 2.5G 25000 SL	S10321642125283	40	6	26	33.5	M5	70	37	36
HSK-E 40 HC08 070 2.5G 25000 SL	S10321643125283	40	8	28	33.5	M6	70	37	36
HSK-E 40 HC10 075 2.5G 25000 SL	S10321644127283	40	10	30	33.5	M6	75	41	42
HSK-E 40 HC12 080 2.5G 25000 SL	S10321636131283	40	12	32	33.5	M6	80	46	48

HSK-E 50 HC06 070 2.5G 25000 SL	S10286642125283	50	6	26	40	M5	70	37	28
HSK-E 50 HC08 070 2.5G 25000 SL	S10286643125283	50	8	28	40	M6	70	37	28
HSK-E 50 HC10 075 2.5G 25000 SL	S10286644127283	50	10	30	40	M8	75	41	34
HSK-E 50 HC12 085 2.5G 25000 SL	S10286636135283	50	12	32	40	M10	85	46	44
HSK-E 50 HC14 085 2.5G 25000 SL	S10286645135283	50	14	34	40	M10	85	46	44
HSK-E 50 HC16 090 2.5G 25000 SL	S10286646140283	50	16	38	42	M12	90	49	30
HSK-E 50 HC18 090 2.5G 25000 SL	S10286647140283	50	18	40	42	M12	90	49	29
HSK-E 50 HC20 090 2.5G 25000 SL	S10286637140283	50	20	42	42	M16	90	51	29

Accessories:



Reduction Sleeve Seal
 (RS Seal) Ref. Page No.52-53

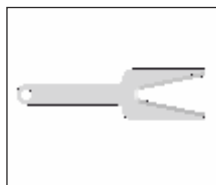

Spanner HC
 Ref. Page No.54

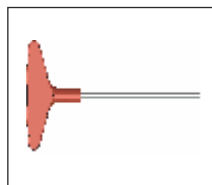

Key HC 5mm
 Ref. Page No.54

Note: All Dimensions are in mm

HSK - F (DIN 69893 - 6) Form F : Technical Information

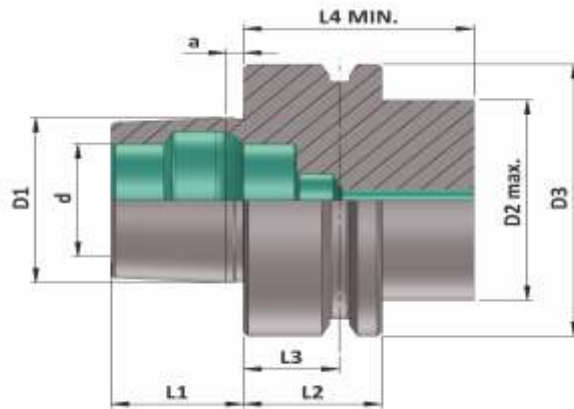

HSK-F	d	D1	D2	D3	a	L1	L2	L3	L4
63	26	38	53	63	5	25	26	18	42

Material :- Case hardened steel, tensile strength in the core min. 950 N/mm²

Execution :- Case hardened to HRC 58 ± 2, Case Depth 0.8 mm., Silver finish.

Accuracy :- Taper Angle Class AT 3

Maximum Run out of the Internal Dia with respect to the External Taper 0.003 mm

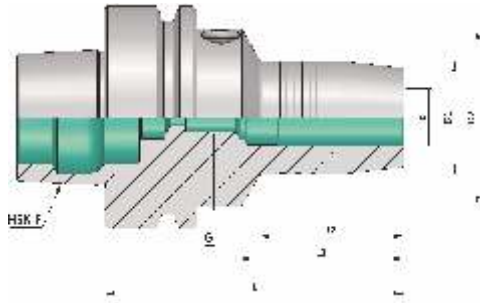

HSK-F (DIN 69893 - 6) Hydraulic Expansion Chuck

(Balanced to 2.5 G 25000 RPM)

Item Name	Item Code	HSK-F	d	D1	D2	G	L	L1	L2
HSK-63F HC06 070 2.5G 25000 SL	S10260642125283	63	6	26	50	M5	70	37	24
HSK-63F HC08 070 2.5G 25000 SL	S10260643125283	63	8	28	50	M6	70	37	25
HSK-63F HC10 080 2.5G 25000 SL	S10260644131283	63	10	30	50	M8	80	41	35
HSK-63F HC12 085 2.5G 25000 SL	S10260636135283	63	12	32	50	M10	85	46	40
HSK-63F HC14 085 2.5G 25000 SL	S10260645135283	63	14	34	50	M10	85	46	40
HSK-63F HC16 090 2.5G 25000 SL	S10260646140283	63	16	38	50	M12	90	49	46
HSK-63F HC18 090 2.5G 25000 SL	S10260647140283	63	18	40	50	M12	90	49	47
HSK-63F HC20 090 2.5G 25000 SL	S10260637140283	63	20	42	50	M16	90	51	48
HSK-63F HC25 120 2.5G 25000 SL	S10260648162283	63	25	57	53	M16	120	57	63

Accessories:



Reduction Sleeve Seal
 (RS Seal) Ref. Page No.52-53

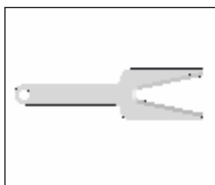

Spanner HC
 Ref. Page No.54

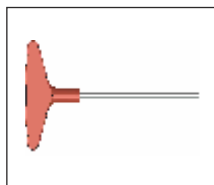

Key HC 5mm
 Ref. Page No.54

Note: All Dimensions are in mm

HSK-C (DIN 69893-1) Form C : Technical Information

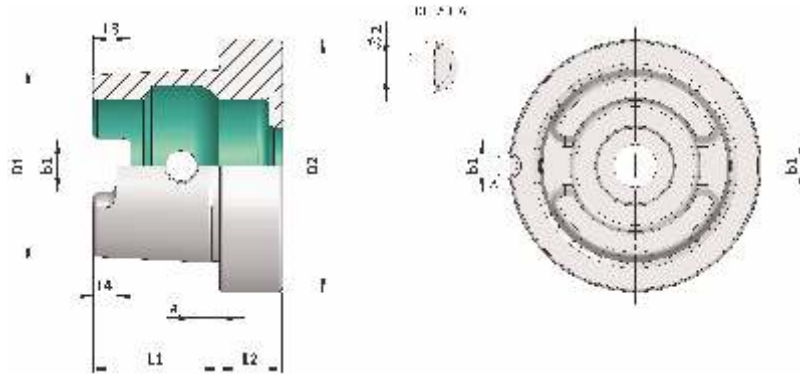

HSK-C	D1	D2	a	b1	L1	L2	L3	L4
40	30	40	4	8.05	20	10	6	3.50
50	38	50	5	10.54	25	12.50	7.50	4.50
63	48	63	6.30	12.54	32	12.50	10	6

Material :- Case hardened steel, tensile strength in the core min. 950 N/mm²

Execution :- Case hardened to HRC 58 ± 2, Case Depth 0.8 mm., Silver finish.

Accuracy :- Taper Angle Class AT 3

Maximum Run out of the Internal Dia with respect to the External Taper 0.003 mm

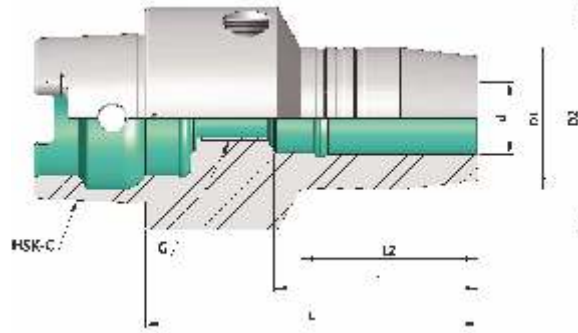

HSK-C (DIN 69893 - 1) Hydraulic Expansion Chuck

(Balanced to 2.5 G 25000 RPM)

Item Name	Item Code	HSK-C	d	D1	D2	G	L	L1	L2
HSK-C 40 HC06 060 2.5G 25000 SL	S10303642117283	40	6	26	40	M5	60	37	35
HSK-C 40 HC08 060 2.5G 25000 SL	S10303643117283	40	8	28	40	M6	60	37	36
HSK-C 40 HC10 065 2.5G 25000 SL	S10303644123283	40	10	30	40	M6	65	41	41
HSK-C 40 HC12 070 2.5G 25000 SL	S10303636125283	40	12	32	40	M6	70	46	47

HSK-C 50 HC06 060 2.5G 25000 SL	S10309642117283	50	6	26	50	M5	60	37	30
HSK-C 50 HC08 060 2.5G 25000 SL	S10309643117283	50	8	28	50	M6	60	37	30
HSK-C 50 HC10 065 2.5G 25000 SL	S10309644123283	50	10	30	50	M8	65	41	35
HSK-C 50 HC12 075 2.5G 25000 SL	S10309636127283	50	12	32	50	M10	75	46	40
HSK-C 50 HC14 075 2.5G 25000 SL	S10309645127283	50	14	34	50	M10	75	46	40
HSK-C 50 HC16 080 2.5G 25000 SL	S10309646131283	50	16	38	50	M12	80	49	50
HSK-C 50 HC18 080 2.5G 25000 SL	S10309647131283	50	18	40	50	M12	80	49	50
HSK-C 50 HC20 080 2.5G 25000 SL	S10309637131283	50	20	42	50	M16	80	51	50
HSK-C 50 HC25 090 2.5G 25000 SL	S10309648140283	50	25	49.5	50	M16	90	57	59

HSK-C 63 HC06 060 2.5G 25000 SL	S10302642117283	63	6	26	63	M5	60	37	25
HSK-C 63 HC08 060 2.5G 25000 SL	S10302643117283	63	8	28	63	M6	60	37	25
HSK-C 63 HC10 065 2.5G 25000 SL	S10302644123283	63	10	30	63	M8	65	41	31
HSK-C 63 HC12 075 2.5G 25000 SL	S10302636127283	63	12	32	63	M10	75	46	41
HSK-C 63 HC14 075 2.5G 25000 SL	S10302645127283	63	14	34	63	M10	75	46	42
HSK-C 63 HC16 080 2.5G 25000 SL	S10302646131283	63	16	38	63	M12	80	49	48
HSK-C 63 HC18 080 2.5G 25000 SL	S10302647131283	63	18	40	63	M12	80	49	48
HSK-C 63 HC20 080 2.5G 25000 SL	S10302637131283	63	20	42	63	M16	80	51	49
HSK-C 63 HC25 095 2.5G 25000 SL	S10302648145283	63	25	58	63	M16	95	57	63
HSK-C 63 HC32 100 2.5G 25000 SL	S10302638148283	63	32	62	63	M16	100	61	60

Accessories:



Reduction Sleeve Seal
 (RS Seal) Ref. Page No.52-53

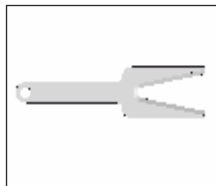

Spanner HC
 Ref. Page No.54

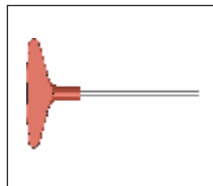

Key HC 5mm
 Ref. Page No.54

Note: All Dimensions are in mm

**BT - DIN ISO 7388 - 2
(MAS 403)**



BT (MAS 403) Form A

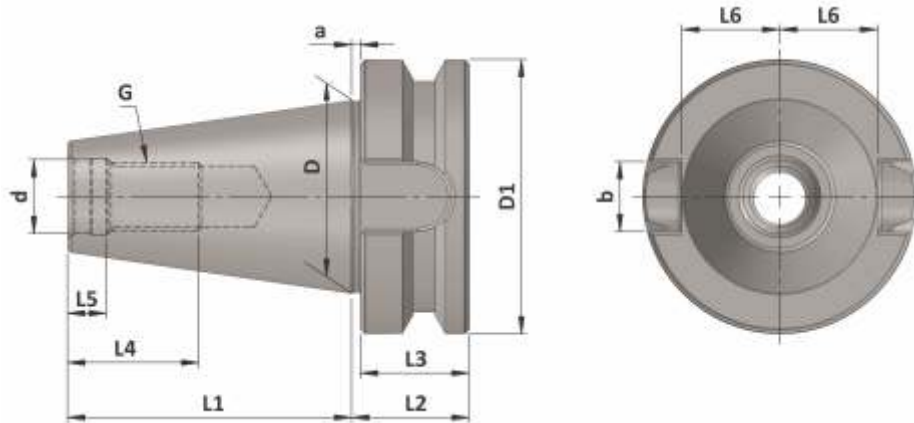

ISO	d	d1	D	D1	a	b	e1	G	L1	L2	L3	L4	L5	L6
30	12.5	-	31.75	46	2	16.1	-	M12	48.4	22	20	24	7.0	16.3
40	17	M4	44.45	63	2	16.1	27	M16	65.4	27	25	32	9.0	22.6
50	25	M6	69.85	100	3	25.7	42	M24	101.8	38	35	47	13.0	35.4

Old Name : BT (MAS 403) Form AD
 New Name : BT (MAS 403) DIN ISO7388 - 2 JD
 (Coolant Supply Through Center)



Old Name : BT (MAS 403) Form AD+B
 New Name : BT (MAS 403) DIN ISO7388 - 2 JD/JF
 (Coolant Supply Through Flange)

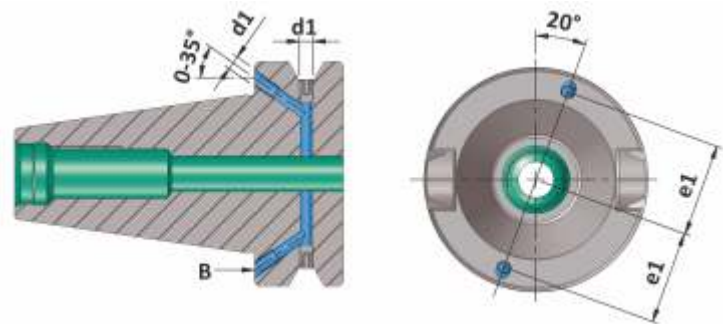

Material :- Case hardened steel, tensile strength in the core min. 950 N/mm²

Execution :- Case hardened to HRC 58 ± 2, Case Depth 0.8 mm., Silver finish.

Accuracy :- 7:24 Taper Angle Class AT 3 As per DIN 2080

Taper Class AT 3 Details

ISO	L	DA-DB	AT 3
30	42	12.280	+0.002
40	59	17.208	+0.003
50	92	26.833	+0.004

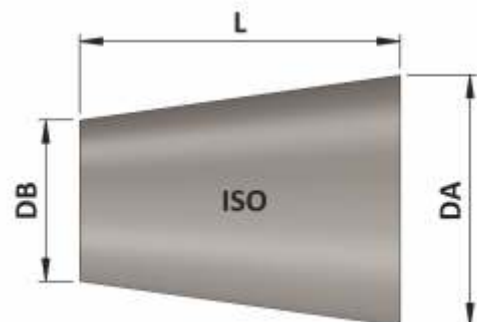

BT (MAS 403) (DIN ISO 7388 - 2)
Hydraulic Expansion Chuck

HEAVY DUTY

Maximum Run out of the Internal Dia with respect to the External Taper 0.003 mm

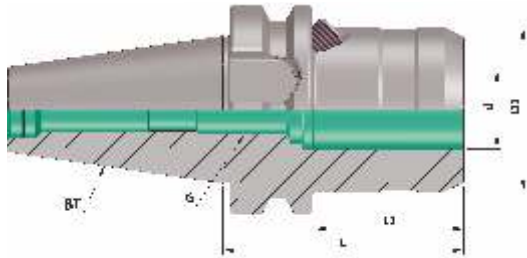

BT (MAS 403) Hydraulic Expansion Chuck (AD)

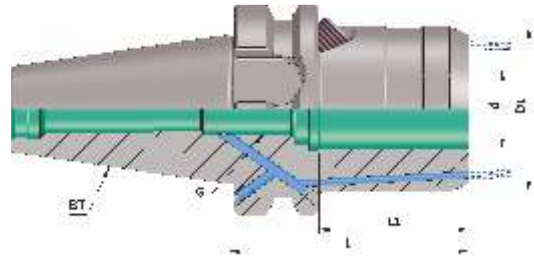

BT (MAS 403) Hydraulic Expansion Chuck (FCC - AD+B)

BT (MAS 403) Hydraulic Expansion Chuck (AD)

(Balanced to 2.5 G 25000 RPM)

Item Name	Item Code	ISO	d	D1	G	L	L1
BT30 HC12S 069 AD/ 2.5G 25000 SL	S10101629616282	30	12	42	M10	69	40
BT30 HC20S 090 AD/ 2.5G 25000 SL	S10101168140282	30	20	50	M16	90	42
BT40 HC12S 058 AD/ 2.5G 25000 SL	S10102629617282	40	12	42	M10	58	40
BT40 HC20S 72.5 AD/ 2.5 G 25000 SL	S10102168126235	40	20	50	M16	72.5	42
BT50 HC12S 069 AD/ 2.5G 25000 SL	S10103629616282	50	12	42	M10	69	40
BT50 HC20S 083 AD/ 2.5G 25000 SL	S10103168618282	50	20	50	M16	83	42
BT50 HC32S 090 AD/ 2.5G 25000 SL	S10103272140282	50	32	72	M16	90	55

BT (MAS 403) Hydraulic Expansion Chuck (FCC - AD+B)

(Balanced to 2.5 G 25000 RPM)

Item Name	Item Code	ISO	d	D1	G	L	L1
BT30 HC12S 069 FCC AD 2.5G 25000 SL	S10101629135227	30	12	42	M10	69	40
BT30 HC20S 090 FCC AD/2.5G 25000 SL	S10101168135129	30	20	50	M16	90	42
BT40 HC12S 058 FCC AD+B/2.5G 25000 SL	S10102629140230	40	12	42	M10	58	40
BT40 HC20S 72.5 FCC AD+B/2.5G 25000 SL	S10102168126140	40	20	50	M16	72.5	42
BT50 HC12S 069 FCC AD+B/2.5G 25000 SL	S10103629338255	50	12	42	M10	69	40
BT50 HC20S 083 FCC AD+B/2.5G 25000 SL	S10103168140140	50	20	50	M16	83	42
BT50 HC32S 090 FCC AD+B/2.5G 25000 SL	S10103272140140	50	32	72	M16	90	55

Accessories:



Reduction Sleeve Seal
(RS Seal) Ref. Page No.52-53

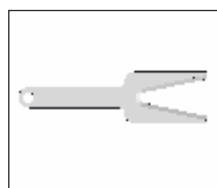

Spanner HC
Ref. Page No.54

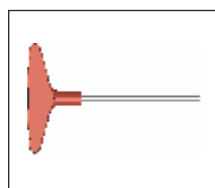

Key HC 5mm
Ref. Page No.54

Note: All Dimensions are in mm

Maximum Run out of the Internal Dia with respect to the External Taper 0.003 mm

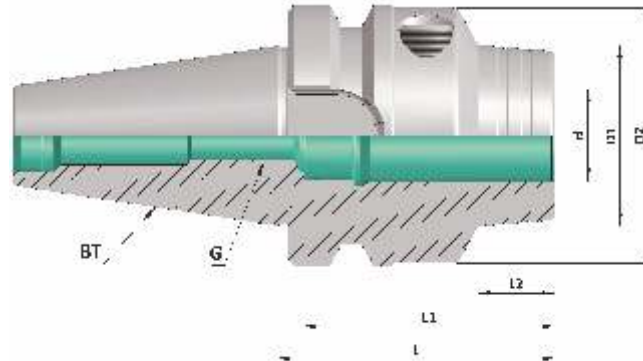

BT (MAS 403) Hydraulic Expansion Chuck (AD)

(Balanced to 2.5 G 25000 RPM)

Item Name	Item Code	ISO	d	D1	D2	G	L	L1	L2
BT30 HC06 50.8 AD/ 2.5G 25000 SL	S10101642619282	30	6	26	45	M5	50.8	37	12
BT30 HC08 50.8 AD/ 2.5G 25000 SL	S10101643619282	30	8	28	45	M6	50.8	37	12.5
BT30 HC10 50.8 AD/ 2.5G 25000 SL	S10101644619282	30	10	30	45	M8	50.8	41	13
BT30 HC12 50.8 AD/ 2.5G 25000 SL	S10101636619282	30	12	32	45	M8	50.8	46	14
BT30 HC12 085 AD/ 2.5G 25000 SL	S10101636135277	30	12	26.5	44.5	M8	85	46	46
BT30 HC14 090 AD/ 2.5G 25000 SL	S10101645140282	30	14	34	45	M8	90	46	45
BT30 HC16 090 AD/ 2.5G 25000 SL	S10101646140282	30	16	38	45	M8	90	49	50
BT30 HC18 090 AD/ 2.5G 25000 SL	S10101647140282	30	18	40	45	M8	90	49	50
BT30 HC20 090 AD/ 2.5G 25000 SL	S10101637140277	30	20	42	45	M8	90	51	50

Accessories:



Reduction Sleeve Seal
 (RS Seal) Ref. Page No.52-53

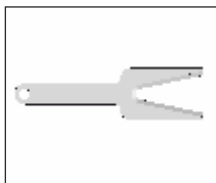

Spanner HC
 Ref. Page No.54

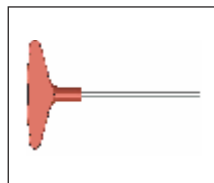

Key HC 5mm
 Ref. Page No.54

Note: All Dimensions are in mm

BT (MAS 403) (DIN ISO 7388 - 2) Hydraulic Expansion Chuck

Maximum Run out of the Internal Dia with respect to the External Taper 0.003 mm

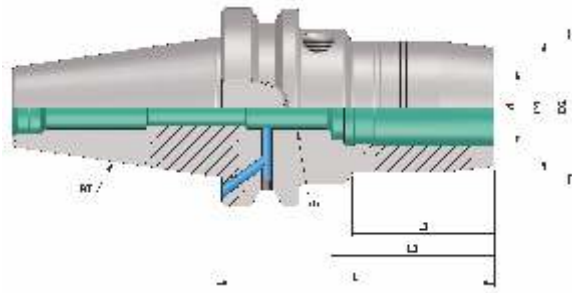

Standard GP

BT (MAS 403) Hydraulic Expansion Chuck (AD+B)

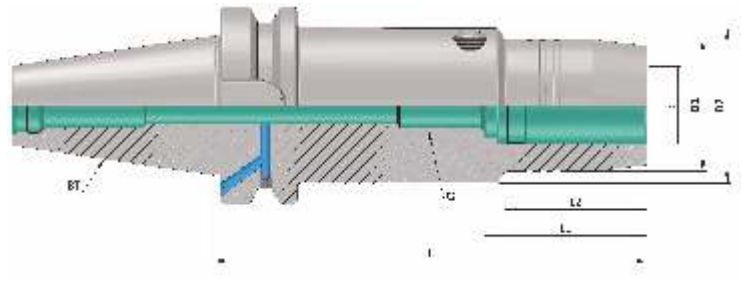

Long GP

BT (MAS 403) Hydraulic Expansion Chuck (AD+B)

BT (MAS 403) Hydraulic Expansion Chuck (AD+B)

(Balanced to 2.5 G 25000 RPM)

Item Name	Item Code	ISO	d	D1	D2	G	L	L1	L2
BT40 HC06 090 AD+B/ 2.5G 25000 SL	S10102642140280	40	6	26	49.5	M5	90	37	29
BT40 HC06 140 AD+B/ 2.5G 25000 SL	S10102642169280	40	6	26	49.5	M5	140	37	29
BT40 HC08 090 AD+B/ 2.5G 25000 SL	S10102643140280	40	8	28	49.5	M6	90	37	30
BT40 HC08 140 AD+B/ 2.5G 25000 SL	S10102643169280	40	8	28	49.5	M6	140	37	30
BT40 HC10 090 AD+B/ 2.5G 25000 SL	S10102644140280	40	10	30	49.5	M8	90	41	35
BT40 HC10 140 AD+B/ 2.5G 25000 SL	S10102644169280	40	10	30	49.5	M8	140	41	35
BT40 HC12 090 AD+B/ 2.5G 25000 SL	S10102636140276	40	12	32	49.5	M10	90	46	40
BT40 HC12 140 AD+B/ 2.5G 25000 SL	S10102636169276	40	12	32	49.5	M10	140	46	40
BT40 HC14 090 AD+B/ 2.5G 25000 SL	S10102645140280	40	14	34	49.5	M10	90	46	40
BT40 HC14 140 AD+B/ 2.5G 25000 SL	S10102645169280	40	14	34	49.5	M10	140	46	40
BT40 HC16 090 AD+B/ 2.5G 25000 SL	S10102646140280	40	16	38	49.5	M12	90	49	45
BT40 HC16 140 AD+B/ 2.5G 25000 SL	S10102646169280	40	16	38	49.5	M12	140	49	45
BT40 HC18 090 AD+B/ 2.5G 25000 SL	S10102647140280	40	18	40	49.5	M12	90	49	46
BT40 HC18 140 AD+B/ 2.5G 25000 SL	S10102647169280	40	18	40	49.5	M12	140	49	46
BT40 HC20 090 AD+B/ 2.5G 25000 SL	S10102637140276	40	20	42	49.5	M16	90	51	47
BT40 HC20 140 AD+B/ 2.5G 25000 SL	S10102637169276	40	20	42	49.5	M16	140	51	47
BT40 HC25 090 AD+B/ 2.5G 25000 SL	S10102648140280	40	25	55	52	M16	90	57	50
BT40 HC25 140 AD+B/ 2.5G 25000 SL	S10102648169280	40	25	55	52	M16	140	57	75
BT40 HC32 090 AD+B/ 2.5G 25000 SL	S10102638140276	40	32	63	62	M16	90	61	48
BT40 HC32 140 AD+B/ 2.5G 25000 SL	S10102638169276	40	32	63	59	M16	140	61	61
BT40 HC1/4" - 90 AD+B/2.5G 25000 SL	S10102649628230	40	1/4"	26	45	M5	90	37	43.5
BT40 HC3/8" - 90 AD+B/2.5G 25000 SL	S10102650628230	40	3/8"	30	45	M8	90	41	44.5
BT40 HC1/2" - 90 AD+B/2.5G 25000 SL	S10102652628230	40	1/2"	32	45	M10	90	46	44.5
BT40 HC5/8" - 90 AD+B/2.5G 25000 SL	S10102651628230	40	5/8"	42	45	M12	90	49	47.5
BT40 HC3/4" - 90 AD+B/2.5G 25000 SL	S10102653628230	40	3/4"	42	45	M16	90	51	47.5

Accessories:



Reduction Sleeve Seal
(RS Seal) Ref. Page No.52-53

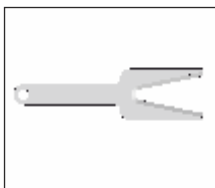

Spanner HC
Ref. Page No.54

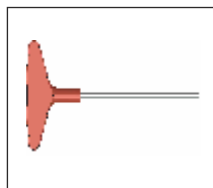

Key HC 5mm
Ref. Page No.54

Note: All Dimensions are in mm

Maximum Run out of the Internal Dia with respect to the External Taper 0.003 mm

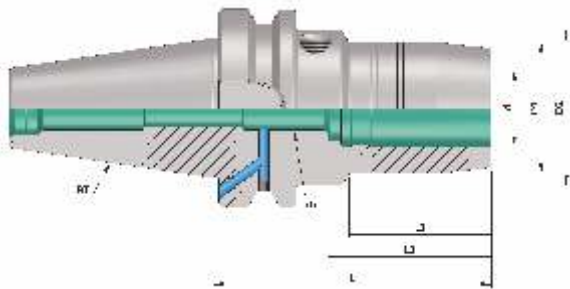

Standard GP

BT (MAS 403) Hydraulic Expansion Chuck (AD+B)

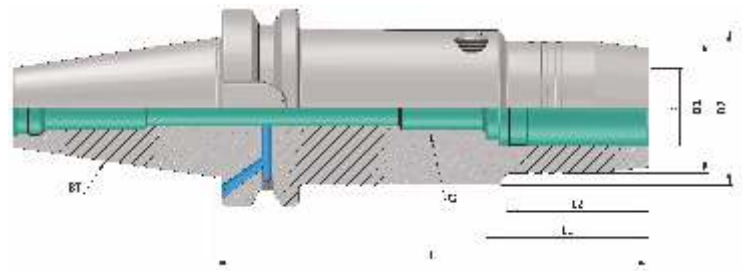

Long GP

BT (MAS 403) Hydraulic Expansion Chuck (AD+B)

BT (MAS 403) Hydraulic Expansion Chuck (AD+B)

(Balanced to 2.5 G 25000 RPM)

Item Name	Item Code	ISO	d	D1	D2	G	L	L1	L2
BT50 HC06 090 AD+B/ 2.5G 25000 SL	S10103642156280	50	6	26	49.5	M5	90	37	29
BT50 HC06 140 AD+B/ 2.5G 25000 SL	S10103642169280	50	6	26	49.5	M5	140	37	29
BT50 HC08 090 AD+B/ 2.5G 25000 SL	S10103643156280	50	8	28	49.5	M6	90	37	30
BT50 HC08 140 AD+B/ 2.5G 25000 SL	S10103643169280	50	8	28	49.5	M6	140	37	30
BT50 HC10 090 AD+B/ 2.5G 25000 SL	S10103644156280	50	10	30	49.5	M8	90	41	34
BT50 HC10 140 AD+B/ 2.5G 25000 SL	S10103644169280	50	10	30	49.5	M8	140	41	35
BT50 HC12 090 AD+B/ 2.5G 25000 SL	S10103636156276	50	12	32	49.5	M10	90	46	34
BT50 HC12 140 AD+B/ 2.5G 25000 SL	S10103636169276	50	12	32	49.5	M10	140	46	40
BT50 HC14 090 AD+B/ 2.5G 25000 SL	S10103645156280	50	14	34	49.5	M10	90	46	34
BT50 HC14 140 AD+B/ 2.5G 25000 SL	S10103645169280	50	14	34	49.5	M10	140	46	40
BT50 HC16 090 AD+B/ 2.5G 25000 SL	S10103646156280	50	16	38	49.5	M12	90	49	35
BT50 HC16 140 AD+B/ 2.5G 25000 SL	S10103646169280	50	16	38	49.5	M12	140	49	45
BT50 HC18 090 AD+B/ 2.5G 25000 SL	S10103647156280	50	18	40	49.5	M12	90	49	35
BT50 HC18 140 AD+B/ 2.5G 25000 SL	S10103647169280	50	18	40	49.5	M12	140	49	46
BT50 HC20 090 AD+B/ 2.5G 25000 SL	S10103637156276	50	20	42	49.5	M16	90	51	35
BT50 HC20 140 AD+B/ 2.5G 25000 SL	S10103637169276	50	20	42	49.5	M16	140	51	42
BT50 HC25 110 AD+B/ 2.5G 25000 SL	S10103648156280	50	25	55	63	M16	110	57	48
BT50 HC25 140 AD+B/ 2.5G 25000 SL	S10103648169280	50	25	55	63	M16	140	57	48
BT50 HC32 110 AD+B/ 2.5G 25000 SL	S10103638159276	50	32	63	70	M16	110	61	50
BT50 HC32 140 AD+B/ 2.5G 25000 SL	S10103638169276	50	32	63	70	M16	140	61	50

Accessories:



Reduction Sleeve Seal
 (RS Seal) Ref. Page No.52-53

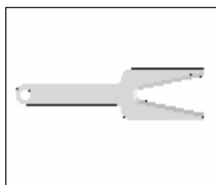

Spanner HC
 Ref. Page No.54

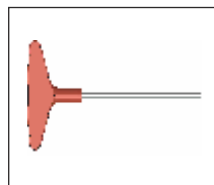

Key HC 5mm
 Ref. Page No.54

Note: All Dimensions are in mm

**BT (MAS 403) (DIN ISO 7388 - 2)
Short GP Hydraulic Chuck**

Maximum Run out of the Internal Dia with respect to the External Taper 0.003 mm

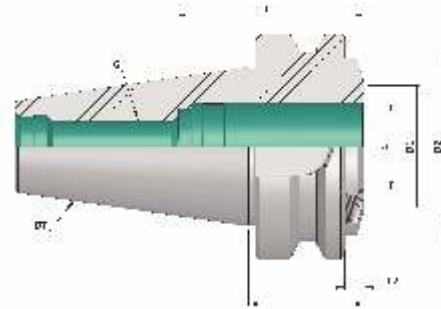

BT (MAS 403) Hydraulic Expansion Chuck (Short GP)

(Balanced to 2.5 G 25000 RPM)

Item Name	Item Code	ISO	d	D1	D2	G	L	L1	L2
BT40 HC20 32.50 SHORT G.P. 2.5G 25000 SL	S10102637615281	40	20	34	49.5	M16	32.5	51	5.50

Accessories:



Reduction Sleeve Seal
(RS Seal) Ref. Page No.52-53

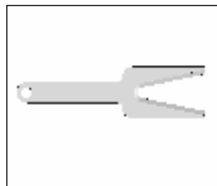

Spanner HC
Ref. Page No.54

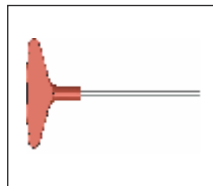

Key HC 5mm
Ref. Page No.54

Note: All Dimensions are in mm

**BBT - (BT MAS 403)
(TAPER & BOTH FACE CONTACT)**



**BBT (BT MAS 403)
TAPER AND BOTH FACE CONTACT HOLDER
(After Clamping)**

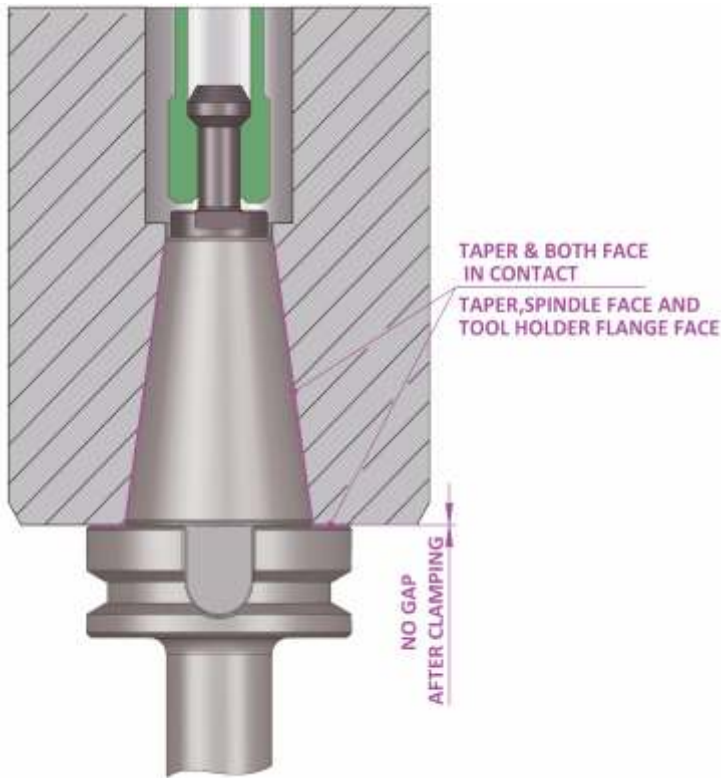

**BT (MAS 403) STANDARD HOLDER
(ONLY TAPER CONTACT)
(After Clamping)**

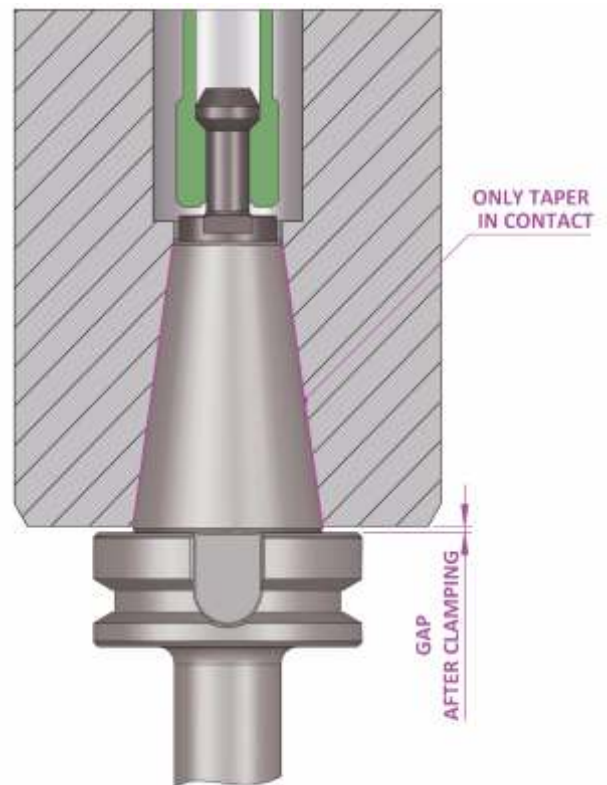

In BBT Tool Holder as mentioned Taper and both faces are in contact, due to which spindle and holder acts as one single unit, this allows a Higher “Radial Rigidity” hence we get good surface finish and dimensional accuracy while machining, also low vibration at higher speeds which increases Tool Life. Hence BBT Tool Holder has a remarkable significant as compared to Standard Tool Holders.

Note :

BBT Tool Holders are only recommended to use in Calibrated BBT Spindle Machines.

BBT (BT MAS 403)

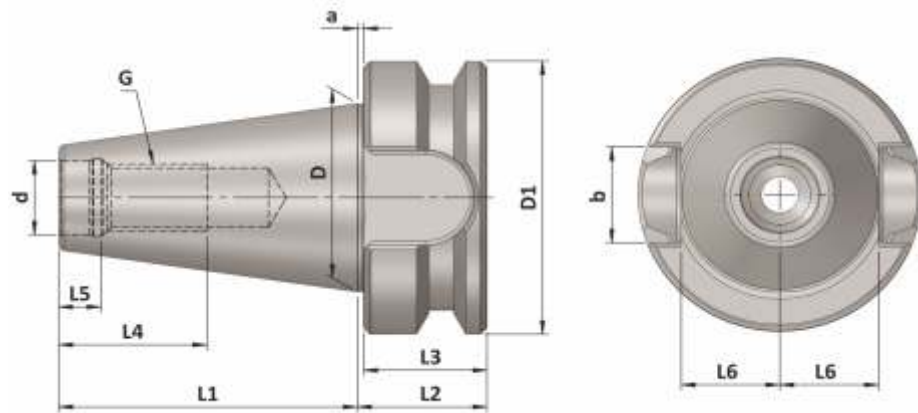

ISO	d	D	D1	a	b	G	L1	L2	L3	L4	L5	L6
30	12.5	31.75	46	1	16.1	M12	48.4	21	20	24	7.0	16.3
40	17	44.45	63	1	16.1	M16	65.4	27	26	32	9.0	22.6
50	25	69.85	100	1.5	25.7	M24	101.8	38	36.5	47	13.0	35.4

◆ Features:

- BBT Tool Holder Provides More “Rigid” Clamping than the Standard “BT” Tool Holders.
- Achieves Higher “Radial Rigidity”
- Improves Tool life.
- Balanced to 2.5 G, 25000 RPM.

Material :- Case hardened steel, tensile strength in the core min. 950 N/mm²

Execution :- Case hardened to HRC 58 ± 2, Case Depth 0.8 mm., Silver finish.

Accuracy :- 7:24 Taper Angle Class AT 3 As per DIN 2080

**BBT (MAS 403) (DIN ISO 7388 - 2) JD
Hydraulic Expansion Chuck**

HEAVY DUTY

Maximum Run out of the Internal Dia with respect to the External Taper 0.003 mm

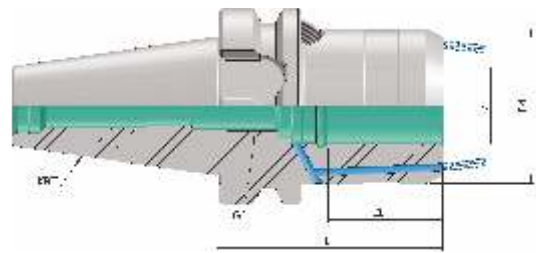
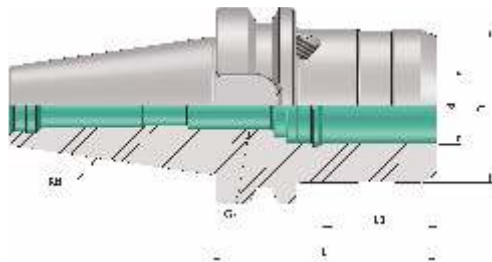

BBT (MAS 403) Hydraulic Expansion Chuck (AD)

BBT (MAS 403) Hydraulic Expansion Chuck (FCC - AD)

BBT (MAS 403) Hydraulic Expansion Chuck (AD)

(Balanced to 2.5 G 25000 RPM)

Item Name	Item Code	ISO	d	D1	G	L	L1
BBT30 HC12S 069 2.5G 25000 SL	S10313629616283	30	12	42	M10	69	40
BBT30 HC20S 090 2.5G 25000 SL	S10313168140283	30	20	50	M16	90	42
BBT40 HC12S 058 2.5G 25000 SL	S10314629617282	40	12	42	M10	58	40
BBT40 HC20S 72.5 2.5G 25000SL	S10314168126228	40	20	50	M16	72.5	42
BBT50 HC12S 069 G2.5 25000 SL	S10315629616281	50	12	42	M10	69	40
BBT50 HC20S 083 2.5G 25000 SL	S10315168618283	50	20	50	M16	83	42
BBT50 HC32S 090 2.5G 25000 SL	S10315272140283	50	32	72	M16	90	55

BBT (MAS 403) Hydraulic Expansion Chuck (FCC - AD)

(Balanced to 2.5 G 25000 RPM)

Item Name	Item Code	ISO	d	D1	G	L	L1
BBT30 HC12S 069 FCC 2.5G 25000 SL	S10313629616256	30	12	42	M10	69	40
BBT30 HC20S 090 FCC 2.5G 25000 SL	S10313168140256	30	20	50	M16	90	42
BBT40 HC12S 058 FCC 2.5G 25000 SL	S10314629111256	40	12	42	M10	58	40
BBT40 HC20S 72.5 FCC 2.5G 25000 SL	S10314168126256	40	20	50	M16	72.5	42
BBT50 HC12S 069 FCC 2.5G 25000 SL	S10315629338256	50	12	42	M10	69	40
BBT50 HC20S 083 FCC 2.5G 25000 SL	S10315168339256	50	20	50	M16	83	42
BBT50 HC32S 090 FCC 2.5G 25000 SL	S10315272140256	50	32	72	M16	90	55

Accessories:



Reduction Sleeve Seal
(RS Seal) Ref. Page No.52-53

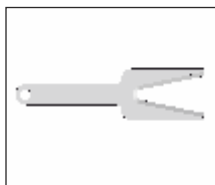

Spanner HC
Ref. Page No.54

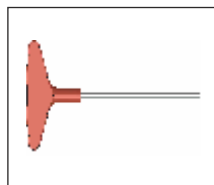

Key HC 5mm
Ref. Page No.54

Note: All Dimensions are in mm

Maximum Run out of the Internal Dia with respect to the External Taper 0.003 mm

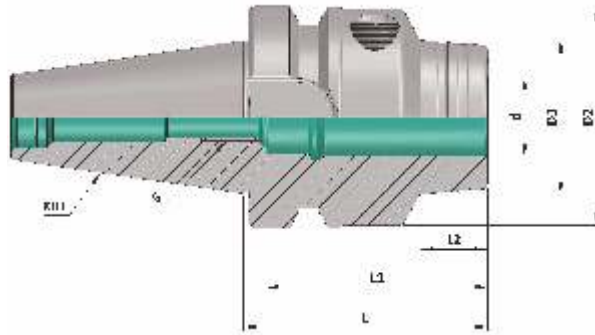

BBT (MAS 403) Hydraulic Expansion Chuck (AD)

(Balanced to 2.5 G 25000 RPM)

Item Name	Item Code	ISO	d	D1	D2	G	L	L1	L2
BBT30 HC06 50.8 2.5G 25000 SL	S10313642619282	30	6	26	45	M5	50.8	37	12
BBT30 HC08 50.8 2.5G 25000 SL	S10313643619282	30	8	28	45	M6	50.8	37	12.5
BBT30 HC10 50.8 2.5G 25000 SL	S10313644619282	30	10	30	45	M8	50.8	41	13
BBT30 HC12 50.8 2.5G 25000 SL	S10313636619282	30	12	32	45	M8	50.8	46	14
BBT30 HC14 090 2.5G 25000 SL	S10313645140282	30	14	34	45	M8	90	46	45
BBT30 HC16 090 2.5G 25000 SL	S10313646140282	30	16	38	45	M8	90	49	50
BBT30 HC18 090 2.5G 25000 SL	S10313647140282	30	18	40	45	M8	90	49	50
BBT30 HC20 090 2.5G 25000 SL	S10313637140282	30	20	42	45	M8	90	51	50

Accessories:



Reduction Sleeve Seal
 (RS Seal) Ref. Page No.52-53

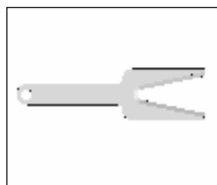

Spanner HC
 Ref. Page No.54

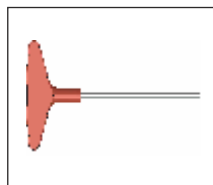

Key HC 5mm
 Ref. Page No.54

Note: All Dimensions are in mm

BBT (MAS 403) (DIN ISO 7388 - 2) JD Hydraulic Expansion Chuck

Maximum Run out of the Internal Dia with respect to the External Taper 0.003 mm

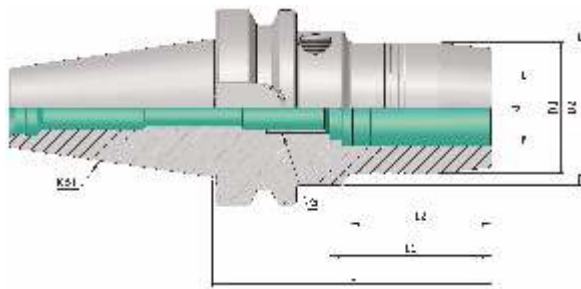

Standard GP

BBT (MAS 403) Hydraulic Expansion Chuck (AD)

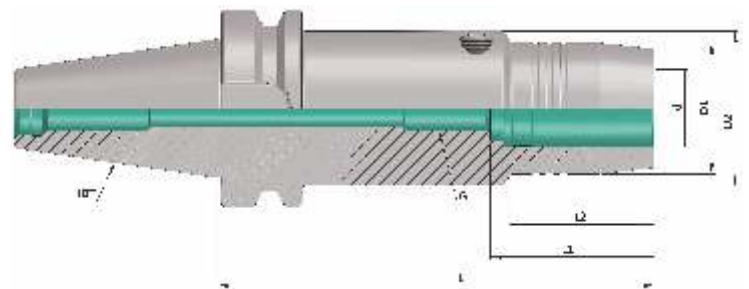

Long GP

BBT (MAS 403) Hydraulic Expansion Chuck (AD)

BBT (MAS 403) Hydraulic Expansion Chuck (AD)

(Balanced to 2.5 G 25000 RPM)

Item Name	Item Code	ISO	d	D1	D2	G	L	L1	L2
BBT40 HC06 090 2.5G 25000 SL	S10314642140282	40	6	26	49.5	M5	90	37	29
BBT40 HC06 140 2.5G 25000 SL	S10314642169282	40	6	26	49.5	M5	140	37	29
BBT40 HC08 090 2.5G 25000 SL	S10314643140282	40	8	28	49.5	M6	90	37	30
BBT40 HC08 140 2.5G 25000 SL	S10314643169282	40	8	28	49.5	M6	140	37	30
BBT40 HC10 090 2.5G 25000 SL	S10314644140282	40	10	30	49.5	M8	90	41	35
BBT40 HC10 140 2.5G 25000 SL	S10314644169282	40	10	30	49.5	M8	140	41	35
BBT40 HC12 090 2.5G 25000 SL	S10314636140282	40	12	32	49.5	M10	90	46	40
BBT40 HC12 140 2.5G 25000 SL	S10314636169282	40	12	32	49.5	M10	140	46	40
BBT40 HC14 090 2.5G 25000 SL	S10314645140282	40	14	34	49.5	M10	90	46	40
BBT40 HC14 140 2.5G 25000 SL	S10314645169282	40	14	34	49.5	M10	140	46	40
BBT40 HC16 090 2.5G 25000 SL	S10314646140282	40	16	38	49.5	M12	90	49	45
BBT40 HC16 140 2.5G 25000 SL	S10314647169282	40	16	38	49.5	M12	140	49	45
BBT40 HC18 090 2.5G 25000 SL	S10314647140282	40	18	40	49.5	M12	90	49	46
BBT40 HC18 140 2.5G 25000 SL	S10314647169282	40	18	40	49.5	M12	140	49	46
BBT40 HC20 090 2.5G 25000 SL	S10314637140282	40	20	42	49.5	M16	90	51	47
BBT40 HC20 140 2.5G 25000 SL	S10314637169282	40	20	42	49.5	M16	140	51	47
BBT40 HC25 090 2.5G 25000 SL	S10314648140282	40	25	52	55	M16	90	57	50
BBT40 HC25 140 2.5G 25000 SL	S10314648169282	40	25	52	55	M16	140	57	75
BBT40 HC32 090 2.5G 25000 SL	S10314638140282	40	32	62	63	M16	90	61	48
BBT40 HC32 140 2.5G 25000 SL	S10314638169282	40	32	59	63	M16	140	61	61

Accessories:



Reduction Sleeve Seal
(RS Seal) Ref. Page No.52-53

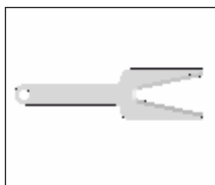

Spanner HC
Ref. Page No.54

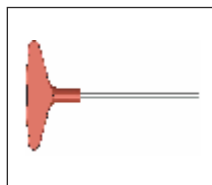

Key HC 5mm
Ref. Page No.54

Note: All Dimensions are in mm

BBT (MAS 403) (DIN ISO 7388 - 2) JD
Hydraulic Expansion Chuck

Maximum Run out of the Internal Dia with respect to the External Taper 0.003 mm

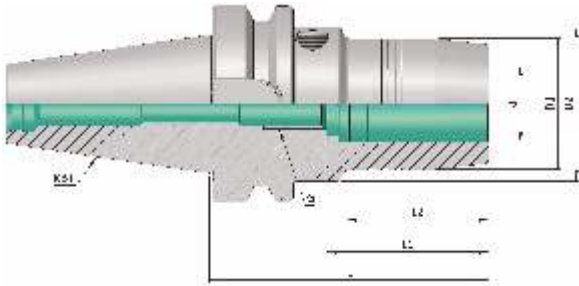

Standard GP

BBT (MAS 403) Hydraulic Expansion Chuck (AD)

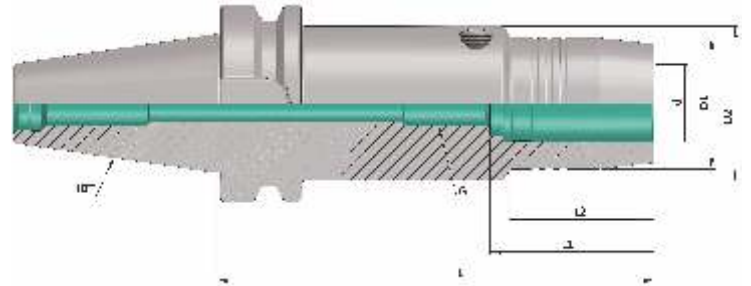

Long GP

BBT (MAS 403) Hydraulic Expansion Chuck (AD)

BBT (MAS 403) Hydraulic Expansion Chuck (AD)

(Balanced to 2.5 G 25000 RPM)

Item Name	Item Code	ISO	d	D1	D2	G	L	L1	L2
BBT50 HC06 090 2.5G 25000 SL	S10315642140282	50	6	26	49.5	M5	90	37	29
BBT50 HC06 140 2.5G 25000 SL	S10315642169282	50	6	26	49.5	M5	140	37	29
BBT50 HC08 090 2.5G 25000 SL	S10315643140282	50	8	28	49.5	M6	90	37	30
BBT50 HC08 140 2.5G 25000 SL	S10315643169282	50	8	28	49.5	M6	140	37	30
BBT50 HC10 090 2.5G 25000 SL	S10315644140282	50	10	30	49.5	M8	90	41	34
BBT50 HC10 140 2.5G 25000 SL	S10315644169282	50	10	30	49.5	M8	140	41	35
BBT50 HC12 090 2.5G 25000 SL	S10315636140282	50	12	32	49.5	M10	90	46	34
BBT50 HC12 140 2.5G 25000 SL	S10315636169282	50	12	32	49.5	M10	140	46	40
BBT50 HC14 090 2.5G 25000 SL	S10315645140282	50	14	34	49.5	M10	90	46	34
BBT50 HC14 140 2.5G 25000 SL	S10315645169282	50	14	34	49.5	M10	140	46	40
BBT50 HC16 090 2.5G 25000 SL	S10315646140282	50	16	38	49.5	M12	90	49	35
BBT50 HC16 140 2.5G 25000 SL	S10315646169282	50	16	38	49.5	M12	140	49	45
BBT50 HC18 090 2.5G 25000 SL	S10315647140282	50	18	40	49.5	M12	90	49	35
BBT50 HC18 140 2.5G 25000 SL	S10315647169282	50	18	42	49.5	M12	140	49	46
BBT50 HC20 090 2.5G 25000 SL	S10315637140282	50	20	40	49.5	M16	90	51	35
BBT50 HC20 140 2.5G 25000 SL	S10315637169282	50	20	42	49.5	M16	140	51	42
BBT50 HC25 110 2.5G 25000 SL	S10315648156282	50	25	55	63	M16	110	57	48
BBT50 HC25 140 2.5G 25000 SL	S10315648169282	50	25	55	63	M16	140	57	48
BBT50 HC32 110 2.5G 25000 SL	S10315638156282	50	32	63	70	M16	110	61	50
BBT50 HC32 140 2.5G 25000 SL	S10315638169282	50	32	63	70	M16	140	61	50

Accessories:



Reduction Sleeve Seal
 (RS Seal) Ref. Page No.52-53

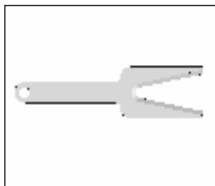

Spanner HC
 Ref. Page No.54

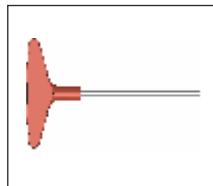

Key HC 5mm
 Ref. Page No.54

Note: All Dimensions are in mm

**BBT (MAS 403) (DIN ISO 7388 - 2)
Short GP Hydraulic Chuck**

Maximum Run out of the Internal Dia with respect to the External Taper 0.003 mm

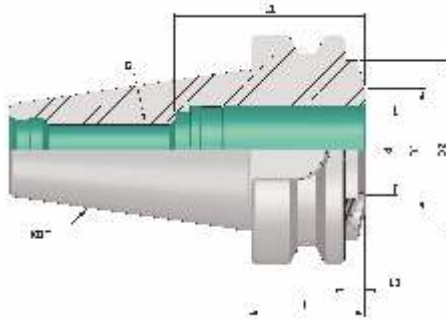

BBT (MAS 403) Hydraulic Expansion Chuck (Short GP)

(Balanced to 2.5 G 25000 RPM)

Item Name	Item Code	ISO	d	D1	D2	G	L	L1	L2
BBT40 HC20 32.50 SHORT G.P. 2.5G 25000 SL	S10314637615283	40	20	34	49.5	M16	32.5	51	5.5

Accessories:



Reduction Sleeve Seal
(RS Seal) Ref. Page No.52-53

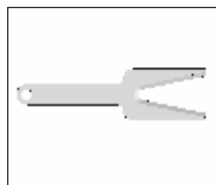

Spanner HC
Ref. Page No.54

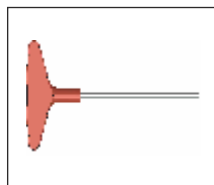

Key HC 5mm
Ref. Page No.54

Note: All Dimensions are in mm

SK - DIN ISO 7388 - 1
(DIN 69871)



SK (DIN 69871) (DIN ISO 7388 - 1) : Technical Information

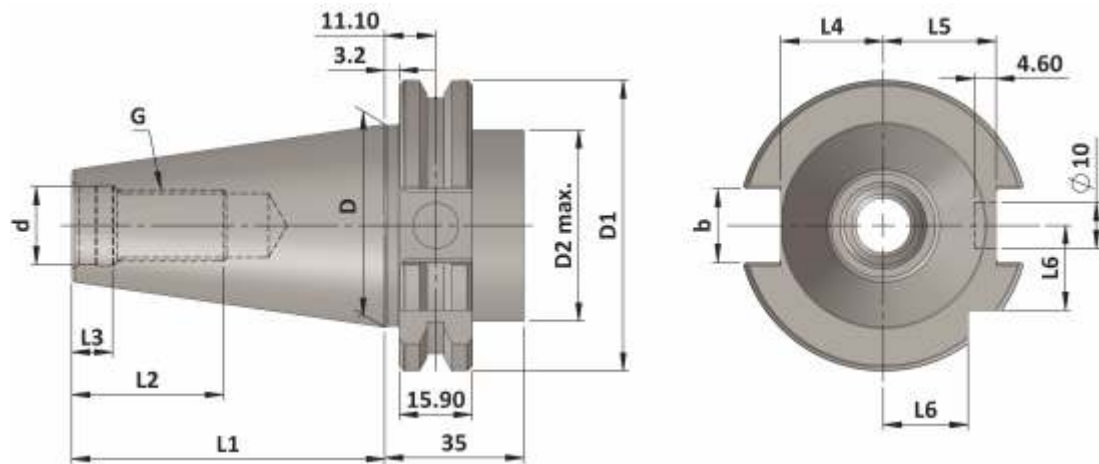

SK	d	d1	D	D1	D2	e	b	G	L1	L2	L3	L4	L5	L6
30	13	4	31.75	50.00	45	21	16.1	M12	47.80	24	5.5	16.4	19.0	15.00
40	17	4	44.45	63.55	50	27	16.1	M16	68.40	32	8.2	22.80	25.0	18.50
50	25	6	69.85	97.50	80	42	25.7	M24	101.75	47	11.5	35.5	37.7	30.00

Material :- Case hardened steel, tensile strength in the core min. 950 N/mm²

Execution :- Case hardened to HRC 58 ± 2, Case Depth 0.8 mm., Silver finish.

Accuracy :- 7:24 Taper Angle Class AT 3 As per DIN 2080

Old Name : SK (DIN 69871) AD

New Name : SK (DIN 69871) DIN ISO 7388- 1 AD
(Coolant Supply Through Center)

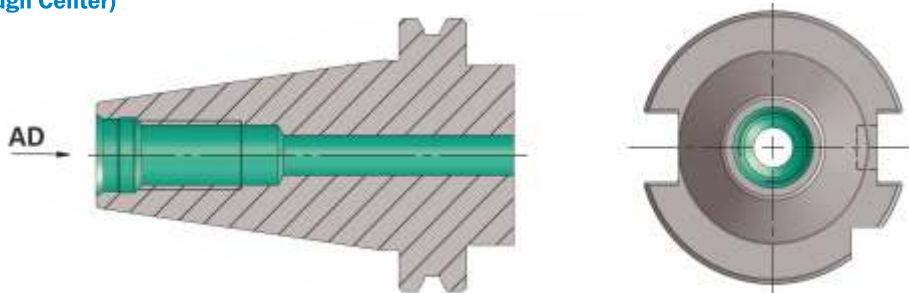

Old Name : SK (DIN 69871) AD+ B

New Name : SK (DIN 69871) DIN ISO 7388- 1 AD / AF
(Coolant Supply Through Flange)

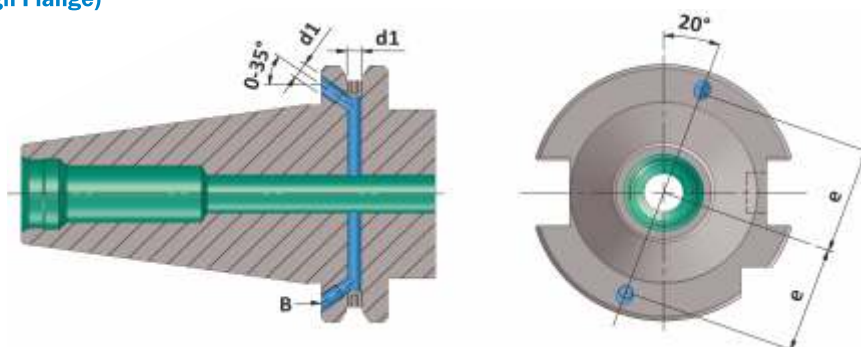

**SK (DIN 69871) (DIN ISO 7388 - 1)
Hydraulic Expansion Chuck**

Maximum Run out of the Internal Dia with respect to the External Taper 0.003 mm

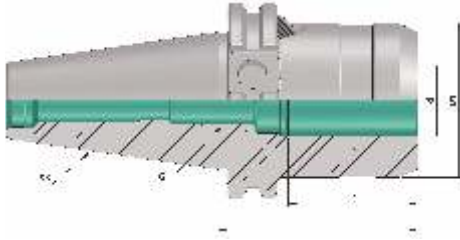

SK (DIN 69871) Hydraulic Expansion Chuck (AD)

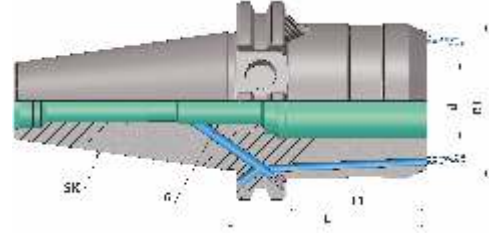

SK (DIN 69871) Hydraulic Expansion Chuck (FCC - AD+B)

SK (DIN 69871) Hydraulic Expansion Chuck (AD)

(Balanced to 2.5 G 25000 RPM)

Item Name	Item Code	SK	d	D1	G	L	L1
SK40 HC12S 050 AD/ 2.5G 25000 SL	S10104629111282	40	12	42	M10	50	40
SK40 HC20S 64.5 AD/ 2.5G 25000 SL	S10104168122282	40	20	50	M16	64.5	42
SK50 HC12S 50.5 AD/ 2.5G 25000 SL	S10105629646282	50	12	42	M10	50.5	40
SK50 HC20S 64.5 AD/ 2.5G 25000 SL	S10105168122282	50	20	50	M16	64.5	42
SK50 HC32S 81.0 AD/ 2.5G 25000 SL	S10105272372282	50	32	72	M16	81	55

SK (DIN 69871) Hydraulic Expansion Chuck (FCC - AD+B)

(Balanced to 2.5 G 25000 RPM)

Item Name	Item Code	SK	d	D1	G	L	L1
SK40 HC12S 050 FCC AD+B/2.5G 25000 SL	S10104629131230	40	12	42	M10	50	40
SK40 HC20S 64.5 FCC AD+B/2.5G 25000 SL	S10104168122140	40	20	50	M16	64.5	42
SK50 HC12S 50.5 FCC AD+B/2.5G 25000 SL	S10105629338255	50	12	42	M10	50.5	40
SK50 HC20S 64.5 FCC AD+B/2.5G 25000 SL	S10105168122230	50	20	50	M16	64.5	42
SK50 HC32S 81.0 FCC AD+B/2.5G 25000 SL	S10105272140140	50	32	72	M16	81	55

Accessories:



Reduction Sleeve Seal
(RS Seal) Ref. Page No.52-53

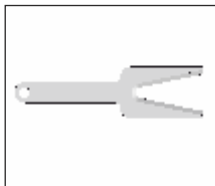

Spanner HC
Ref. Page No.54

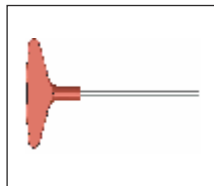

Key HC 5mm
Ref. Page No.54

Note: All Dimensions are in mm

SK (DIN 69871) (DIN ISO 7388 - 1) Hydraulic Expansion Chuck

Maximum Run out of the Internal Dia with respect to the External Taper 0.003 mm

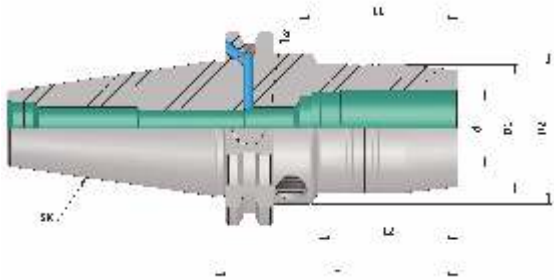

Standard GP

SK (DIN 69871) Hydraulic Expansion Chuck (AD+B)

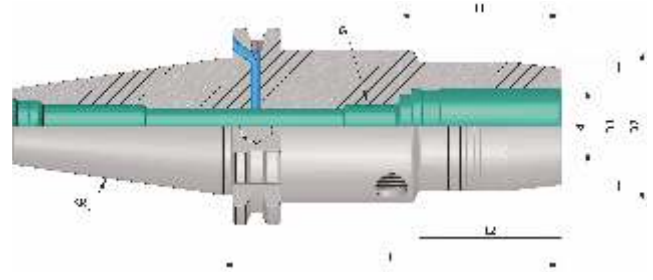

Long GP

SK (DIN 69871) Hydraulic Expansion Chuck (AD+B)

SK (DIN 69871) Hydraulic Expansion Chuck (AD+B)

(Balanced to 2.5 G 25000 RPM)

Item Name	Item Code	SK	d	D1	D2	G	L	L1	L2
SK40 HC06 80.5 AD+B/ 2.5G 25000 SL	S10104642131280	40	6	26	49.5	M5	80.5	37	29.5
SK40 HC06 110 AD+B/ 2.5G 25000 SL	S10104642156280	40	6	26	49.5	M5	110	37	29
SK40 HC08 80.5 AD+B/ 2.5G 25000 SL	S10104643131280	40	8	28	49.5	M6	80.5	37	30
SK40 HC08 110 AD+B/ 2.5G 25000 SL	S10104643156280	40	8	28	49.5	M6	110	37	30
SK40 HC10 80.5 AD+B/ 2.5G 25000 SL	S10104644131280	40	10	30	49.5	M8	80.5	41	35
SK40 HC10 110 AD+B/ 2.5G 25000 SL	S10104644156280	40	10	30	49.5	M8	110	41	35
SK40 HC12 80.5 AD+B/ 2.5G 25000 SL	S10104636131276	40	12	32	49.5	M10	80.5	46	40
SK40 HC12 110 AD+B/ 2.5G 25000 SL	S10104636156276	40	12	32	49.5	M10	110	46	40
SK40 HC14 80.5 AD+B/ 2.5G 25000 SL	S10104645131280	40	14	34	49.5	M10	80.5	46	40
SK40 HC14 110 AD+B/ 2.5G 25000 SL	S10104645156280	40	14	34	49.5	M10	110	46	40
SK40 HC16 80.5 AD+B/ 2.5G 25000 SL	S10104646131280	40	16	38	49.5	M12	80.5	49	45
SK40 HC16 110 AD+B/ 2.5G 25000 SL	S10104646156280	40	16	38	49.5	M12	110	49	45
SK40 HC18 80.5 AD+B/ 2.5G 25000 SL	S10104647131280	40	18	40	49.5	M12	80.5	49	46
SK40 HC18 110 AD+B/ 2.5G 25000 SL	S10104647156280	40	18	40	49.5	M12	110	49	46
SK40 HC20 80.5 AD+B/ 2.5G 25000 SL	S10104637131276	40	20	42	49.5	M16	80.5	51	47
SK40 HC20 110 AD+B/ 2.5G 25000 SL	S10104637156276	40	20	42	49.5	M16	110	51	47
SK40 HC25 095 AD+B/ 2.5G 25000 SL	S10104648145280	40	25	55	63	M16	95	57	28
SK40 HC25 110 AD+B/ 2.5G 25000 SL	S10104648156280	40	25	55	63	M16	110	57	28
SK40 HC32 095 AD+B/ 2.5G 25000 SL	S10104638145276	40	32	63	70	M16	95	61	25.5
SK40 HC32 110 AD+B/ 2.5G 25000 SL	S10104638156276	40	32	63	59	M16	110	61	59

Accessories:



Reduction Sleeve Seal
(RS Seal) Ref. Page No.52-53

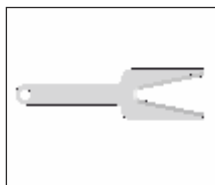

Spanner HC
Ref. Page No.54

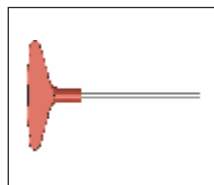

Key HC 5mm
Ref. Page No.54

Note: All Dimensions are in mm

Maximum Run out of the Internal Dia with respect to the External Taper 0.003 mm

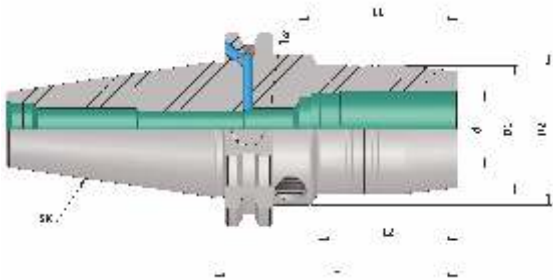

Standard GP

SK (DIN 69871) Hydraulic Expansion Chuck (AD+B)

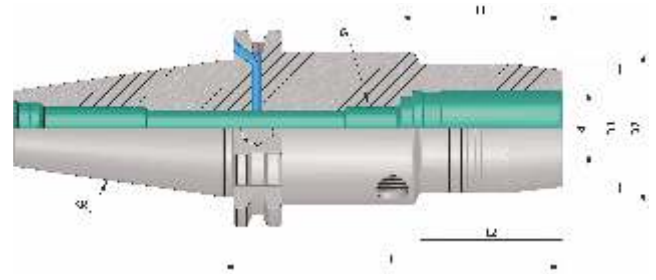

Long GP

SK (DIN 69871) Hydraulic Expansion Chuck (AD+B)

SK (DIN 69871) Hydraulic Expansion Chuck (AD+B)

(Balanced to 2.5 G 25000 RPM)

Item Name	Item Code	SK	d	D1	D2	G	L	L1	L2
SK50 HC06 80.5 AD+B/ 2.5G 25000 SL	S10105642131280	50	6	26	49.5	M5	80.5	37	29.5
SK50 HC06 110 AD+B/ 2.5G 25000 SL	S10105642156280	50	6	26	49.5	M5	110	37	29
SK50 HC08 80.5 AD+B/ 2.5G 25000 SL	S10105643131280	50	8	28	49.5	M6	80.5	37	30
SK50 HC08 110 AD+B/ 2.5G 25000 SL	S10105643156280	50	8	28	49.5	M6	110	37	30
SK50 HC10 80.5 AD+B/ 2.5G 25000 SL	S10105644131280	50	10	30	49.5	M8	80.5	41	35
SK50 HC10 110 AD+B/ 2.5G 25000 SL	S10105644156280	50	10	30	49.5	M8	110	41	35
SK50 HC12 80.5 AD+B/ 2.5G 25000 SL	S10105636131276	50	12	32	49.5	M10	80.5	46	40
SK50 HC12 110 AD+B/ 2.5G 25000 SL	S10105636156276	50	12	32	49.5	M10	110	46	40
SK50 HC14 80.5 AD+B/ 2.5G 25000 SL	S10105645131280	50	14	34	49.5	M10	80.5	46	40
SK50 HC14 110 AD+B/ 2.5G 25000 SL	S10105645156280	50	14	34	49.5	M10	110	46	40
SK50 HC16 80.5 AD+B/ 2.5G 25000 SL	S10105646131280	50	16	38	49.5	M12	80.5	49	45
SK50 HC16 110 AD+B/ 2.5G 25000 SL	S10105646156280	50	16	38	49.5	M12	110	49	45
SK50 HC18 80.5 AD+B/ 2.5G 25000 SL	S10105647131280	50	18	40	49.5	M12	80.5	49	46
SK50 HC18 110 AD+B/ 2.5G 25000 SL	S10105647156280	50	18	40	49.5	M12	110	49	46
SK50 HC20 80.5 AD+B/ 2.5G 25000 SL	S10105637131276	50	20	42	49.5	M16	80.5	51	42
SK50 HC20 110 AD+B/ 2.5G 25000 SL	S10105637156276	50	20	42	49.5	M16	110	51	42
SK50 HC25 100 AD+B/ 2.5G 25000 SL	S10105648148280	50	25	55	63	M16	100	57	48
SK50 HC25 110 AD+B/ 2.5G 25000 SL	S10105648162280	50	25	55	63	M16	110	57	48
SK50 HC32 100 AD+B/ 2.5G 25000 SL	S10105638148276	50	32	63	70	M16	100	61	61
SK50 HC32 110 AD+B/ 2.5G 25000 SL	S10105638162276	50	32	63	70	M16	110	61	61

Accessories:



Reduction Sleeve Seal
 (RS Seal) Ref. Page No.52-53

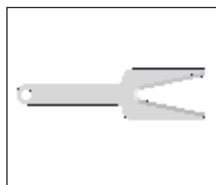

Spanner HC
 Ref. Page No.54

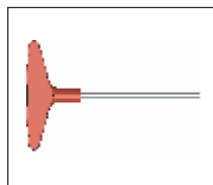

Key HC 5mm
 Ref. Page No.54

Note: All Dimensions are in mm

SK (DIN 69871) (DIN ISO 7388 - 1)
Hydraulic Expansion Chuck
For TOOL & CUTTER CNC Grinding Machines

Maximum Run out of the Internal Dia with respect to the External Taper 0.003 mm

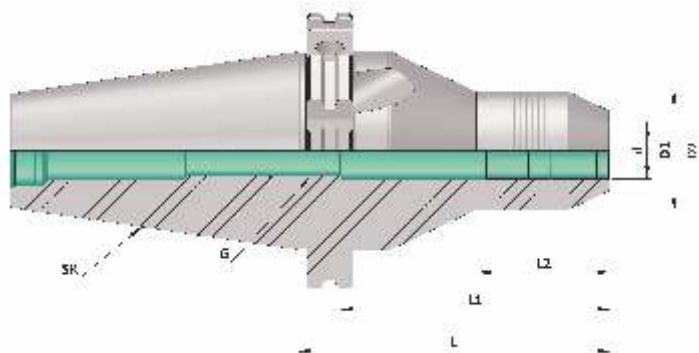

SK (DIN 69871) Hydraulic Expansion Chuck (AD)

(Balanced to 2.5 G 25000 RPM)

Item Name	Item Code	SK	d	D1	D2	G	L	L1	L2
SK50 HC06 110 (TOOL & CUTTER) AD/ 2.5G 25000 SL	S10105642629282	50	6	32	60	M5	110	43	45
SK50 HC08 110 (TOOL & CUTTER) AD/ 2.5G 25000 SL	S10105643629282	50	8	33.5	60	M6	110	43	50
SK50 HC10 110 (TOOL & CUTTER) AD/ 2.5G 25000 SL	S10105644629282	50	10	35	60	M8	110	43	50
SK50 HC12 110 (TOOL & CUTTER) AD/ 2.5G 25000 SL	S10105636629282	50	12	36.5	60	M10	110	50	55
SK50 HC14 110 (TOOL & CUTTER) AD/ 2.5G 25000 SL	S10105645629282	50	14	38	60	M10	110	50	60
SK50 HC16 110 (TOOL & CUTTER) AD/ 2.5G 25000 SL	S10105646629282	50	16	39.5	60	M12	110	53	60
SK50 HC18 110 (TOOL & CUTTER) AD/ 2.5G 25000 SL	S10105647629282	50	18	41	60	M12	110	53	60
SK50 HC20 110 (TOOL & CUTTER) AD/ 2.5G 25000 SL	S10105637629282	50	20	42	70	M16	110	95	41
SK50 HC25 110 (TOOL & CUTTER) AD/ 2.5G 25000 SL	S10105648629282	50	25	47	70	M16	110	95	40
SK50 HC32 110 (TOOL & CUTTER) AD/ 2.5G 25000 SL	S10105638629282	50	32	54	70	M16	110	95	56

Accessories:



Reduction Sleeve Seal
 (RS Seal) Ref. Page No.52-53

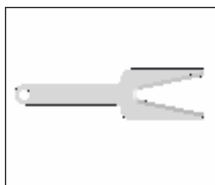

Spanner HC
 Ref. Page No.54

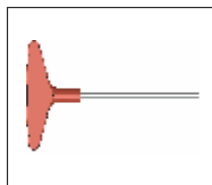

Key HC 4mm
 Ref. Page No.54

Note: All Dimensions are in mm

Maximum Run out of the Internal Dia with respect to the External Taper 0.003 mm

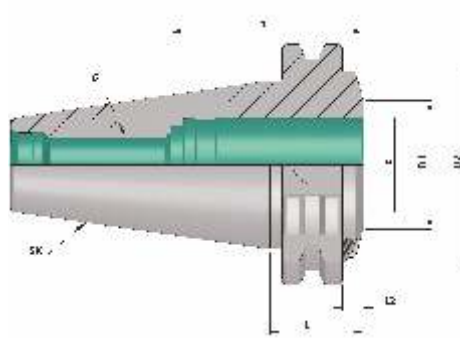

SK (DIN 69871) Hydraulic Expansion Chuck (Short GP)

(Balanced to 2.5 G 25000 RPM)

Item Name	Item Code	SK	d	D1	D2	G	L	L1	L2
SK40 HC20 24.60 SHORT G.P. 2.5G 25000 SL	S10104637614281	40	20	34	49.5	M16	24.6	51	5.5

Accessories:



Reduction Sleeve Seal
 (RS Seal) Ref. Page No.52-53

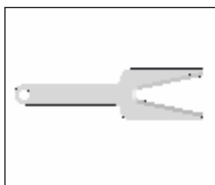

Spanner HC
 Ref. Page No.54

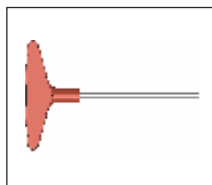

Key HC 5mm
 Ref. Page No.54

Note: All Dimensions are in mm

CAT - (ANSI B 5.50)



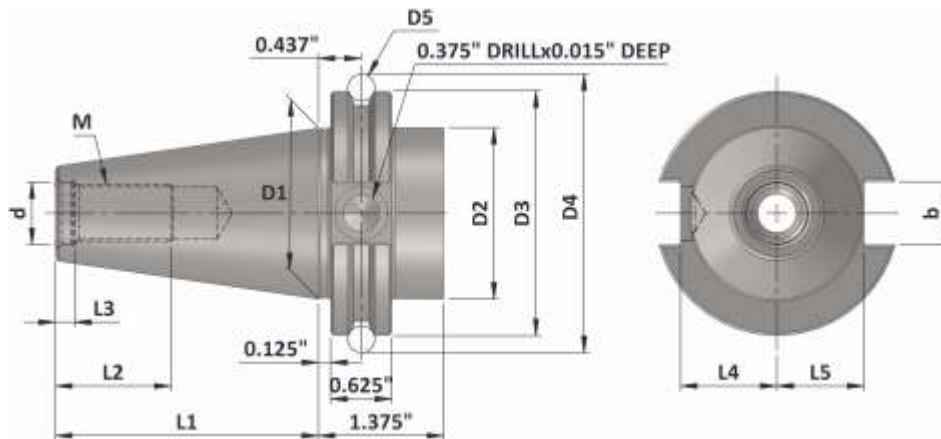

CAT	d	D1	D2	D3	D4	D5	b	M UNC 2B	L1	L2	L3	L4	L5
40	0.641"	1.750"	1.750"	2.500"	2.863"	0.2813"	0.645"	5/8" - 11"	2.687"	1.12"	0.188"	0.985"	0.890"
50	1.031"	2.750"	2.750"	3.875"	4.238"	0.2813"	1.020"	1" - 8"	4.000"	1.75"	0.250"	1.485"	1.390"

Material :- Case hardened steel, tensile strength in the core min. 950 N/mm²

Execution :- Case hardened to HRC 58 ± 2, Case Depth 0.8 mm., Silver finish.

Accuracy :- 7:24 Taper Angle Class AT 3 As per DIN 2080

**CAT (ANSI B 5.50)
Hydraulic Expansion Chuck**

HEAVY DUTY

Maximum Run out of the Internal Dia with respect to the External Taper 0.003 mm

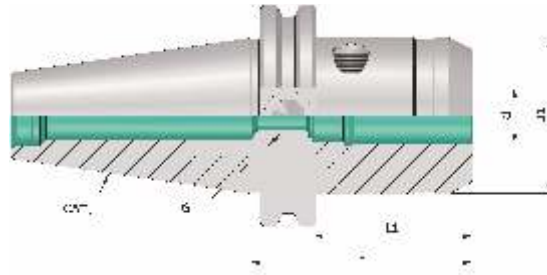

CAT (ANSI B 5.50) Hydraulic Expansion Chuck (Heavy Duty)

(Balanced to 2.5 G 25000 RPM)

Item Name	Item Code	CAT	d	D1	G	L	L1
CAT40 HC1/2" - 64 HD 2.5G 25000 SL	S10203652621230	40	1/2"	44.5	M10	64	46
CAT40 HC5/8" - 64 HD 2.5G 25000 SL	S10203651621230	40	5/8"	44.5	M12	64	49
CAT40 HC3/4" - 64 HD 2.5G 25000 SL	S10203653621230	40	3/4"	44.5	M16	64	51

Accessories:



Reduction Sleeve Seal
(RS Seal) Ref. Page No.52-53

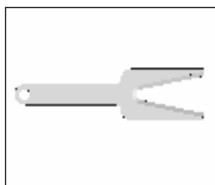

Spanner HC
Ref. Page No.54

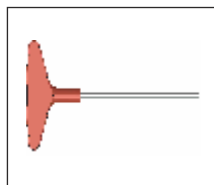

Key HC 5mm
Ref. Page No.54

Note: All Dimensions are in mm

Maximum Run out of the Internal Dia with respect to the External Taper 0.003 mm

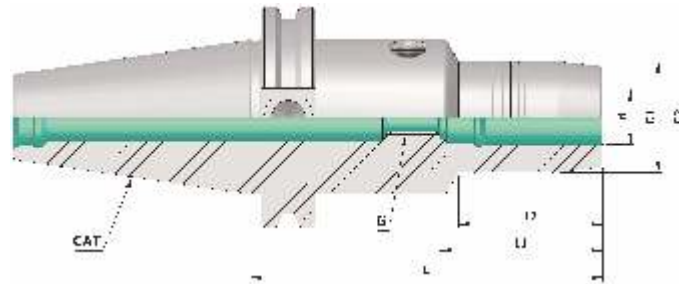

CAT (ANSI B 5.50) Hydraulic Expansion Chuck

(Balanced to 2.5 G 25000 RPM)

Item Name	Item Code	CAT	d	D1	D2	G	L	L1	L2
CAT40 HC06 - 101.60 2.5G 25000 SL	S10203642620230	40	6	26	44.5	M5	101.6	37	32.5
CAT40 HC08 - 101.60 2.5G 25000 SL	S10203643620230	40	8	28	44.5	M6	101.6	37	35.5
CAT40 HC10 - 101.60 2.5G 25000 SL	S10203644620230	40	10	30	44.5	M8	101.6	41	41.5
CAT40 HC12 - 101.60 2.5G 25000 SL	S10203636620230	40	12	32	44.5	M10	101.6	46	41.5
CAT40 HC14 - 101.60 2.5G 25000 SL	S10203645620230	40	14	34	44.5	M10	101.6	46	49.5
CAT40 HC16 - 101.60 2.5G 25000 SL	S10203646620230	40	16	38	44.5	M12	101.6	49	49.5
CAT40 HC18 - 101.60 2.5G 25000 SL	S10203647620230	40	18	40	44.5	M12	101.6	49	49.5
CAT40 HC20 - 101.60 2.5G 25000 SL	S10203637620230	40	20	42	44.5	M16	101.6	51	49.5
CAT40 HC25 - 101.60 2.5G 25000 SL	S10203648620230	40	25	55	65	M16	101.6	57	66
CAT40 HC32 - 101.60 2.5G 25000 SL	S10203638620230	40	32	63	80	M16	101.6	61	56

CAT40 HC1/4" - 101.60 2.5G 25000 SL	S10203649620230	40	1/4"	26	44.5	M5	101.6	37	32.5
CAT40 HC3/8" - 101.60 2.5G 25000 SL	S10203650620230	40	3/8"	30	44.5	M8	101.6	41	41.5
CAT40 HC1/2" - 101.60 2.5G 25000 SL	S10203652620230	40	1/2"	32	44.5	M10	101.6	46	41.5
CAT40 HC5/8" - 101.60 2.5G 25000 SL	S10203651620230	40	5/8"	38	44.5	M12	101.6	49	49.5
CAT40 HC3/4" - 101.60 2.5G 25000 SL	S10203653620230	40	3/4"	42	44.5	M16	101.6	51	49.5
CAT40 HC 1.0" - 101.60 2.5G 25000 SL	S10203656620230	40	1"	55	61	M16	101.6	57	66.5
CAT40 HC1-1/4" - 101.60 2.5G 25000 SL	S10203655620230	40	1-1/4"	61	61	M16	101.6	61	-

Accessories:



Reduction Sleeve Seal
 (RS Seal) Ref. Page No.52-53

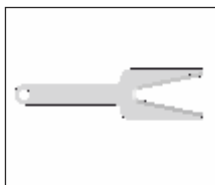

Spanner HC
 Ref. Page No.54

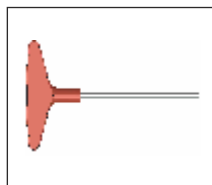

Key HC 5mm
 Ref. Page No.54

Note: All Dimensions are in mm

CAT (ANSI B 5.50) Hydraulic Expansion Chuck

Maximum Run out of the Internal Dia with respect to the External Taper 0.003 mm

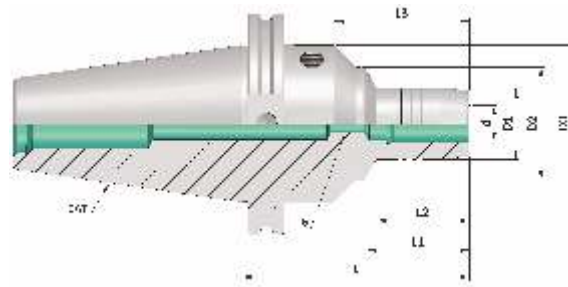

CAT (ANSI B 5.50) Hydraulic Expansion Chuck

(Balanced to 2.5 G 25000 RPM)

Item Name	Item Code	CAT	d	D1	D2	D3	G	L	L1	L2	L3
CAT50 HC06 - 101.60 2.5G 25000 SL	S10204642620230	50	6	26	69.85	50.3	M5	101.6	37	32.5	60.5
CAT50 HC08 - 101.60 2.5G 25000 SL	S10204643620230	50	8	28	69.85	50.3	M6	101.6	37	36	60.5
CAT50 HC10 - 101.60 2.5G 25000 SL	S10204644620230	50	10	30	69.85	50.3	M8	101.6	41	36	60.5
CAT50 HC12 - 101.60 2.5G 25000 SL	S10204636620230	50	12	32	69.85	50.3	M10	101.6	46	41.5	60.5
CAT50 HC14 - 101.60 2.5G 25000 SL	S10204645620230	50	14	34	69.85	50.3	M10	101.6	46	41.5	60.5
CAT50 HC16 - 101.60 2.5G 25000 SL	S10204646620230	50	16	38	69.85	50.3	M12	101.6	49	47.5	60.5
CAT50 HC18 - 101.60 2.5G 25000 SL	S10204647620230	50	18	40	69.85	50.3	M12	101.6	49	47.5	60.5
CAT50 HC20 - 101.60 2.5G 25000 SL	S10204637620230	50	20	42	69.85	50.3	M16	101.6	51	49.5	60.5
CAT50 HC25 - 101.60 2.5G 25000 SL	S10204648620230	50	25	57	69.85	63	M16	101.6	57	49.5	64
CAT50 HC32 - 101.60 2.5G 25000 SL	S10204638620230	50	32	64	69.85	-	M16	101.6	61	65	-

CAT50 HC1/4" - 101.60 2.5G 25000 SL	S10204649620230	50	1/4"	26	69.85	50.25	M5	101.6	37	32.5	60.5
CAT50 HC3/8" - 101.60 2.5G 25000 SL	S10204650620230	50	3/8"	30	69.85	50.25	M8	101.6	41	36	60.5
CAT50 HC1/2" - 101.60 2.5G 25000 SL	S10204652620230	50	1/2"	32	69.85	50.25	M10	101.6	46	41.5	60.5
CAT50 HC5/8" - 101.60 2.5G 25000 SL	S10204651620230	50	5/8"	38	69.85	50.25	M12	101.6	49	47.5	60.5
CAT50 HC3/4" - 101.60 2.5G 25000 SL	S10204653620230	50	3/4"	42	69.85	50.25	M16	101.6	51	49.5	60.5
CAT50 HC 1.0" - 101.60 2.5G 25000 SL	S10204656620230	50	1"	57	69.85	63	M16	101.6	57	49.5	64
CAT50 HC1-1/4" - 101.60 2.5G 25000 SL	S10204655620230	50	1-1/4"	64	69.85	-	M16	101.6	61	65	-

Accessories:



Reduction Sleeve Seal
(RS Seal) Ref. Page No.52-53

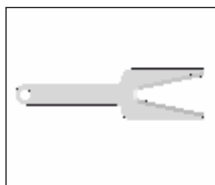

Spanner HC
Ref. Page No.54

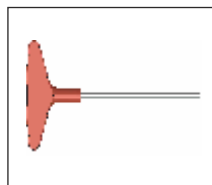

Key HC 5mm
Ref. Page No.54

Note: All Dimensions are in mm

Maximum Run out of the Internal Dia with respect to the External Taper 0.003 mm

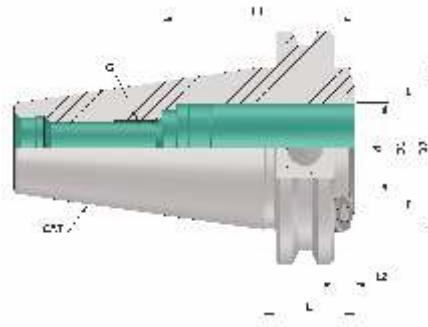

CAT (ANSI B5.50) Hydraulic Expansion Chuck (Short GP)

(Balanced to 2.5 G 25000 RPM)

Item Name	Item Code	CAT	d	D1	D2	G	L	L1	L2
CAT40 HC3/4" 24.60 SHORT G.P. 2.5G 25000 SL	S10203653614283	40	3/4"	34	44.45	M16	24.6	51	5.55

Accessories:



Reduction Sleeve Seal
 (RS Seal) Ref. Page No.52-53

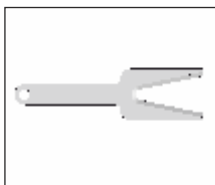

Spanner HC
 Ref. Page No.54

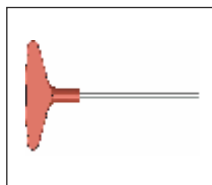

Key HC 5mm
 Ref. Page No.54

Note: All Dimensions are in mm

**Cylindrical Shank
VDI Shank
ER Type**



Cylindrical Hydraulic Chuck

Maximum Run out of the Internal Dia with respect to the External Dia 0.003 mm

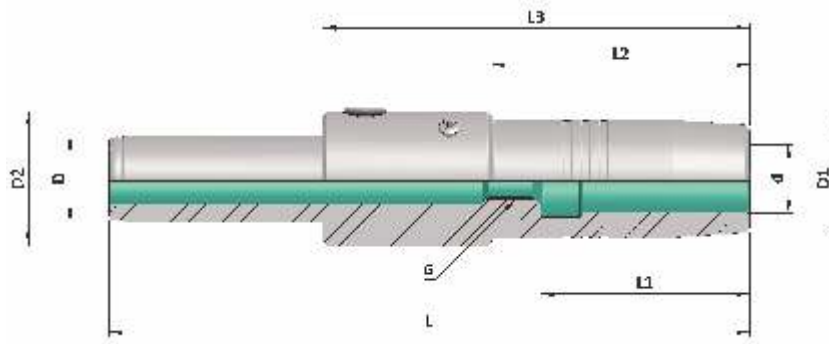

Cylindrical Hydraulic Chuck

Item Name	Item Code	d	D	D1	D2	G	L	L1	L2	L3
DIA20 HC06 L 150	S10160642236127	6	20	16	25	M5	150	37	54	100
DIA20 HC08 L 150	S10160643236127	8	20	18	25	M5	150	37	54	100
DIA20 HC10 L 150	S10160644236127	10	20	20	25	M6	150	41	54	100
DIA20 HC12 L 150	S10160636236127	12	20	25	25	M6	150	46	100	100
DIA20 HC16 L 150	S10160646236127	16	20	27.5	31.5	M10	150	49	60	100
DIA20 HC20 L 150	S10160637236127	20	20	31.5	31.5	M10	150	51	100	100
DIA32 HC20 L 150	S10162637236127	20	32	31.5	31.5	M10	150	51	90	90
DIA32 HC20 L 200	S10162637237127	20	32	31.5	31.5	M10	200	51	90	90

Accessories:



Reduction Sleeve Seal
(RS Seal) Ref. Page No.52-53

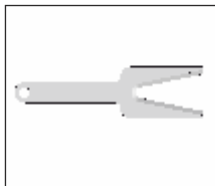

Spanner HC
Ref. Page No.54

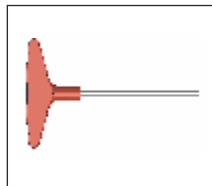

Key HC 5mm
Ref. Page No.54

Note: All Dimensions are in mm

Cylindrical Hydraulic Chuck

Maximum Run out of the Internal Dia with respect to the External Dia 0.003 mm

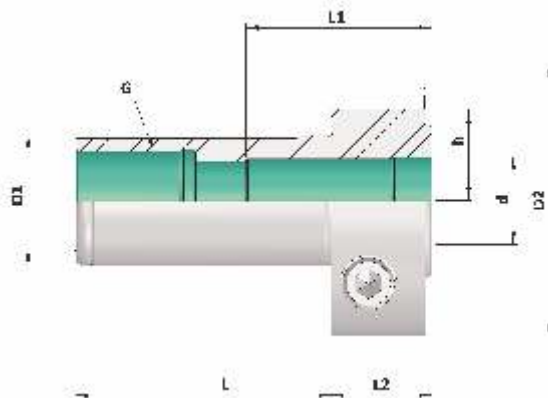

Cylindrical Hydraulic Chuck

Item Name	Item Code	d	D1	D2	G	h	L	L1	L2
DIA25 HC12 L049	S10261636630127	12	25	52	M18	17.5	49	35.5	19.5
DIA 25 HC16 L056	S10285646631127	16	25	56	M18	17.5	56	40	19.5
DIA 32 HC20 L059	S10333637632127	20	32	60	M18	21.5	59	42.8	19.5

Accessories:



Reduction Sleeve Seal
(RS Seal) Ref. Page No.52-53

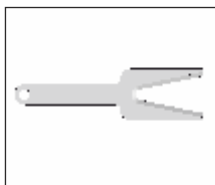

Spanner HC
Ref. Page No.54

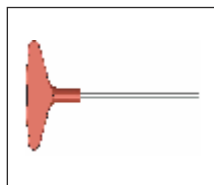

Key HC 5mm
Ref. Page No.54

Note: All Dimensions are in mm

Maximum Run out of the Internal Dia with respect to the External Dia 0.003 mm

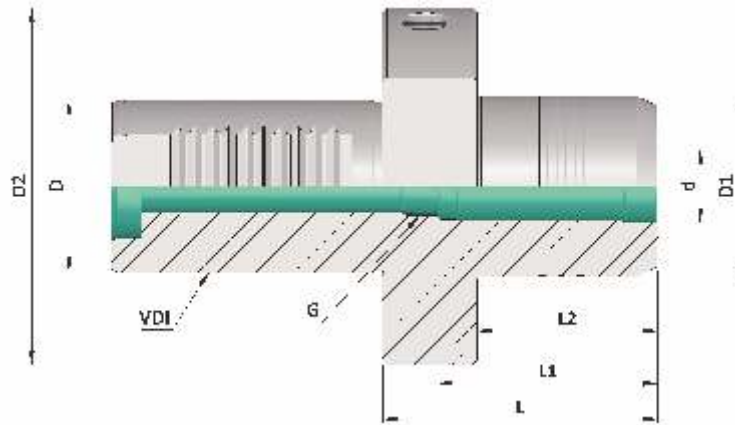

VDI Shank Hydraulic Chuck

Item Name	Item Code	VDI	d	D	D1	D2	G	L	L1	L2
VDI 25 HC12 L055 (with stopper)	S10285636633127	25	12	25	32	58	M10	55	46	37
VDI30 HC20 L064 (with stopper)	S10261637634127	30	20	30	42	68	M16	64	51	42
VDI40 HC20 L064 (with stopper)	S10262637634127	40	20	40	42	83	M20	64	51	42
VDI30 HC32 L086 (without stopper)	S10261638635127	30	32	30	64	68	-	86	-	64
VDI40 HC32 L086 (without stopper)	S10262638635127	40	32	40	64	83	-	86	-	64

Accessories:



Reduction Sleeve Seal
 (RS Seal) Ref. Page No.52-53

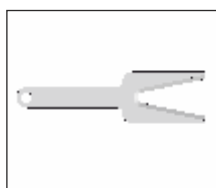

Spanner HC
 Ref. Page No.54

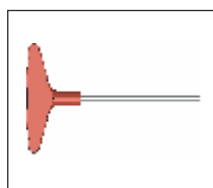

Key HC 5mm
 Ref. Page No.54

Note: All Dimensions are in mm

“ER” Type Hydraulic Chuck

SIGMA “ER” Hydraulic Chucks

◆ Features :

- Best suitable for positive driven tools.
- you can easily convert standard “ER” series holders into High Precision “ER” Hydraulic Chucks.
- Easy to handle & maintenance free design.
- 2 to 3 times clamping force compared to standard “ER” Collect Chucks.
- With the help of 3 Axial clamping screws, it is possible to adjust tool run out precisely (**0.002 mm is possible**), hence increases the tool life as well as productivity.

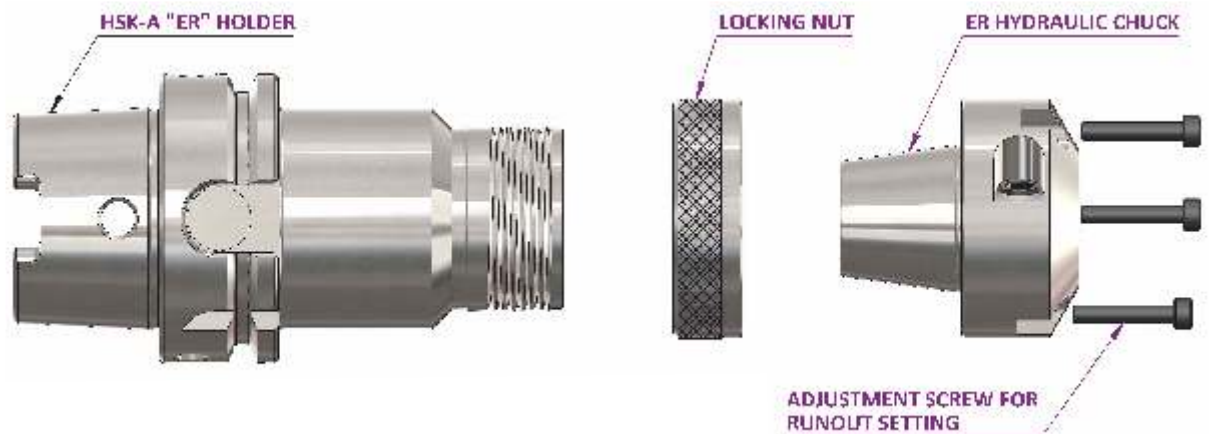

ER Type Hydraulic Chuck

Maximum Run out of the Internal Dia with respect to the External Taper 0.003 mm

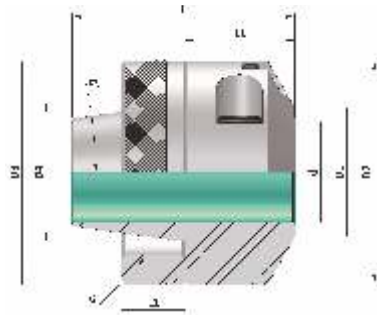

ER Type Hydraulic Chuck

Item Name	Item Code	ER	d	D1	D2	D3	D4	G	L	L1	L2
ER 16 HC06	S10322642301127	16	6	16	34	34	16	M22X1.5	30	14	10
ER 16M HC06	S10327642301127	16M	6	16	34	34	16	M19 X1	30	14	10
ER 16 HC1/4"	S10322649301127	16	1/4"	16	34	34	16	M22 X 1.5	30	14	10
ER 20 HC12	S10324636301127	20	12	22	43.5	43.5	20	M25 X 1.5	40	24	12
ER 20M HC12	S10328636301127	20M	12	22	43.5	43.5	20	M24 X 1	40	24	12
ER 20 HC1/2"	S10324652301127	20	1/2"	22	43.5	43.5	20	M25 X 1.5	40	24	12
ER 20M HC1/2"	S10328652301127	20M	1/2"	22	43.5	43.5	20	M24 X 1	40	24	12
ER 25 HC12	S10323636301127	25	12	26	48	48	25	M32 X 1.5	46	26	15
ER 25M HC12	S10329636301127	25M	12	26	48	48	25	M30 X 1	46	26	15
ER 25 HC16	S10323646301127	25	16	26	48	48	25	M32 X 1.5	46	26	15
ER 25M HC16	S10329646301127	25M	16	26	48	48	25	M30 X 1	46	26	15
ER 25 HC1/2"	S10323652301127	25	1/2"	26	48	48	25	M32 X 1.5	46	26	15
ER 25 HC5/8"	S10323651301127	25	5/8"	26	48	48	25	M32 X 1.5	46	26	15
ER 32 HC20	S10325637301127	32	20	30	52	52	32	M40X1.5	52	25.5	15
ER 32 HC3/4"	S10325653301127	32	3/4"	30	52	52	32	M40X1.5	52	25.5	15
ER 40 HC25	S10326648301127	40	25	35	59	62	40	M50X1.5	56	22	20
ER 40 HC 1.0"	S10326656301127	40	1"	35	59	62	40	M50X1.5	56	22	20

Accessories:



Reduction Sleeve Seal
(RS Seal) Ref. Page No.52-53

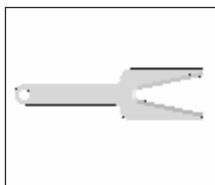

Spanner HC
Ref. Page No.54

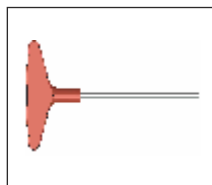

Key HC 4mm/Key HC 5mm
Ref. Page No.54

Note: All Dimensions are in mm

Reduction Sleeve Seal (RS Seal) For Hydraulic Expansion Chuck

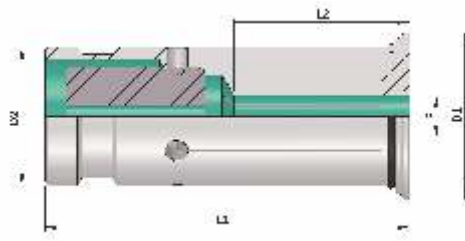

Reduction Sleeve Seal (RS Seal)

Concentricity within 0.005mm

Item Name	Item Code	d	D1	D2	L1	L2
RS SEAL 12 X 3	S10251209556127	3	16.50	12	48	14
RS SEAL 12 X 4	S10251209528127	4	16.50	12	48	15
RS SEAL 12 X 5	S10251209561127	5	16.50	12	48	18
RS SEAL 12 X 6	S10251209342127	6	16.50	12	48	25
RS SEAL 12 X 8	S10251209314127	8	16.50	12	48	26

RS SEAL 20 X 3	S10251217323127	3	29	20	52.5	14
RS SEAL 20 X 4	S10251217434127	4	29	20	52.5	15
RS SEAL 20 X 5	S10251217442127	5	29	20	52.5	18
RS SEAL 20 X 6	S10312185301127	6	29	20	52.5	25
RS SEAL 20 X 7	S10251217426127	7	29	20	52.5	25
RS SEAL 20 X 8	S10251217443127	8	29	20	52.5	30
RS SEAL 20 X 9	S10251217415127	9	29	20	52.5	30
RS SEAL 20 X 10	S10251217416127	10	29	20	52.5	33
RS SEAL 20 X 11	S10251217444127	11	29	20	52.5	33
RS SEAL 20 X 12	S10251217445127	12	29	20	52.5	34
RS SEAL 20 X 13	S10251217417127	13	29	20	52.5	34
RS SEAL 20 X 14	S10251217418127	14	29	20	52.5	34
RS SEAL 20 X 15	S10251217419127	15	29	20	52.5	40
RS SEAL 20 X 16	S10312195301127	16	29	20	52.5	40

RS SEAL 32 X 6	S10251229324127	6	39	32	63.5	25
RS SEAL 32 X 8	S10251229325127	8	39	32	63.5	25
RS SEAL 32 X 10	S10251229322127	10	39	32	63.5	33
RS SEAL 32 X 12	S10251229327127	12	39	32	63.5	34
RS SEAL 32 X 14	S10251229326127	14	39	32	63.5	34
RS SEAL 32 X 16	S10251229420127	16	39	32	63.5	40
RS SEAL 32 X 18	S10251229501127	18	39	32	63.5	40
RS SEAL 32 X 20	S10251229554127	20	39	32	63.5	40
RS SEAL 32 X 25	S10251229481127	25	39	32	63.5	42

Note: All Dimensions are in mm

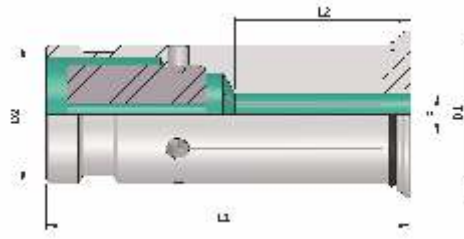

Reduction Sleeve Seal (RS Seal)

Concentricity within 0.005mm

Item Name	Item Code	d	D1	D2	L1	L2
RS SEAL 1/2" - 1/8" (3.175)	S10334658636127	1/8"(3.175)	16.50	1/2" (12.70)	48	14
RS SEAL 1/2" - 3/16" (4.7625)	S10334659637127	3/16" (4.7625)	16.50	1/2" (12.70)	48	18
RS SEAL 1/2" - 1/4" (6.350)	S10334660638127	1/4" (6.350)	16.50	1/2" (12.70)	48	25
RS SEAL 1/2" - 5/16" (7.9375)	S10334661639127	5/16" (7.9375)	16.50	1/2" (12.70)	48	26

RS SEAL 3/4" - 1/8" (3.175)	S10335658636127	1/8" (3.175)	29	3/4"(19.05)	52.50	14
RS SEAL 3/4" - 3/16" (4.7625)	S10335659637127	3/16" (4.7625)	29	3/4"(19.05)	52.50	18
RS SEAL 3/4" - 1/4" (6.350)	S10335660638127	1/4" (6.350)	29	3/4"(19.05)	52.50	25
RS SEAL 3/4" - 5/16" (7.9375)	S10335661639127	5/16" (7.9375)	29	3/4"(19.05)	52.50	30
RS SEAL 3/4" - 3/8" (9.525)	S10335667640127	3/8" (9.525)	29	3/4"(19.05)	52.50	33
RS SEAL 3/4" - 1/2" (12.700)	S10335662641127	1/2" (12.700)	29	3/4"(19.05)	52.50	34
RS SEAL 3/4" - 5/8" (15.875)	S10335667640127	5/8" (15.875)	29	3/4"(19.05)	52.50	40

RS SEAL 1-1/4" - 1/4" (6.350)	S10336660638127	1/4" (6.350)	39	1 1/4" (31.750)	63.50	25
RS SEAL 1-1/4" - 5/16" (7.9375)	S10336661639127	5/16" (7.9375)	39	1 1/4" (31.750)	63.50	25
RS SEAL 1-1/4" - 3/8" (9.525)	S10336667640127	3/8" (9.525)	39	1 1/4" (31.750)	63.50	33
RS SEAL 1-1/4" - 1/2" (12.700)	S10336662641127	1/2" (12.700)	39	1 1/4" (31.750)	63.50	34
RS SEAL 1-1/4" - 5/8" (15.875)	S10336663642127	5/8" (15.875)	39	1 1/4" (31.750)	63.50	40
RS SEAL 1-1/4" - 3/4" (19.050)	S10336664643127	3/4" (19.050)	39	1 1/4" (31.750)	63.50	40
RS SEAL 1-1/4" - 1" (25.400)	S10336665644127	1" (25.400)	39	1 1/4" (31.750)	63.50	42

Note: All Dimensions are in mm

Hydraulic Expansion Chuck KIT



Item Name	Item Code
BT30 HC12S 069 KIT	S10101629616279
BT30 HC20S 090 KIT	S10101168140279

BT40 HC12S 058 KIT	S10102629617279
BT40 HC20S 72.5 KIT	S10102168126279

BT50 HC12S 069 KIT	S10103629616279
BT50 HC20S 083 KIT	S10103168618279
BT50 HC32S 090 KIT	S10103272140279

KBT30 HC12S 069 KIT	S10313629616279
KBT30 HC20S 090 KIT	S10313168616279

KBT40 HC12S 058 KIT	S10314629617279
KBT40 HC20S 72.5 KIT	S10314168126279

KBT50 HC12S 069 KIT	S10315629616279
KBT50 HC20S 083 KIT	S10315168618279
KBT50 HC32S 090 KIT	S10315272140279

Item Name	Item Code
SK40 HC12S 050 KIT	S10104629111287
SK40 HC20S 64.5 KIT	S10104168122287

SK50 HC12S 050 KIT	S10105629111287
SK50 HC20S 64.5 KIT	S10105168122287
SK50 HC32S 81.0 KIT	S10105272372287

HSK-A 50 HC12S 085 KIT	S10306629135279
HSK-A 50 HC20S 090 KIT	S10306168140279

HSK-A 63 HC12S 080 KIT	S10316629131279
HSK-A 63 HC20S 080 KIT	S10316168131279

HSK-A 100 HC12S 095 KIT	S10168629145279
HSK-A 100 HC20S 090 KIT	S10168168140279
HSK-A 100 HC32S 110 KIT	S10168272156279

CAT40 HC1/2" 64.0 KIT	S10203652278279
CAT40 HC3/4" 64.0 KIT	S10203653278279
CAT40 HC5/8" 64.0 KIT	S10203651278279

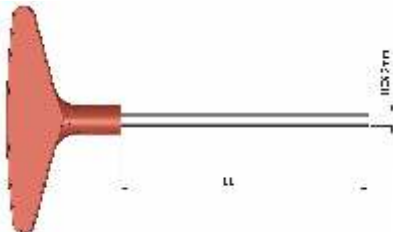

KEY HC

Accessories

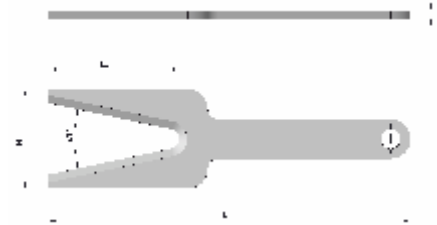

SPANNER HC

Item Name	Item Code	L	L1	H	T	HEX
KEY HC 4mm	S10337641336127	-	110	-	-	4
KEY HC 5mm	S10337668645127	-	110	-	-	5
SPANNER HC	S10184641301127	182	65	50	-	-

Tool Run out Inspection

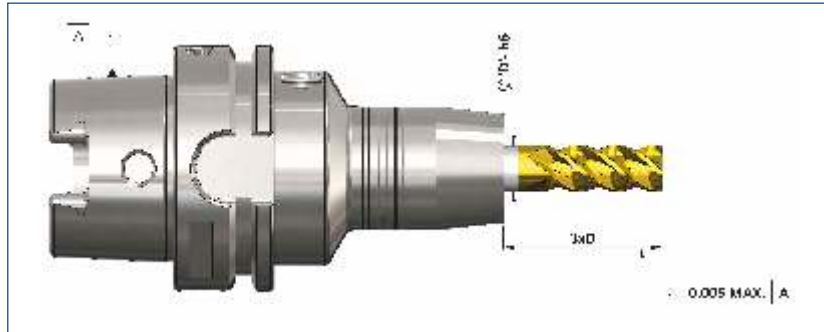

Controlled Run out Guaranteed 0.005 mm max on 3D WITH TOOL CLAMPING

Guideline for Tool Clamping

Correct way of Tool Clamping



CLAMPING WITH RS SLEEVE

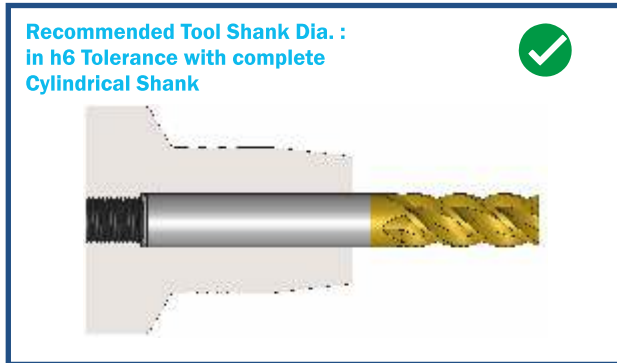

DIRECT CLAMPING

Incorrect way of Tool Clamping

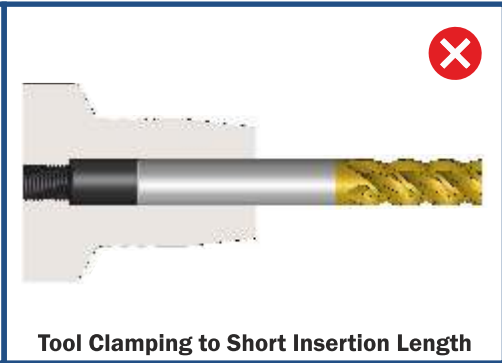
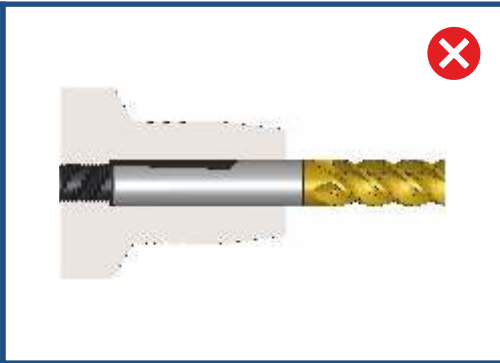
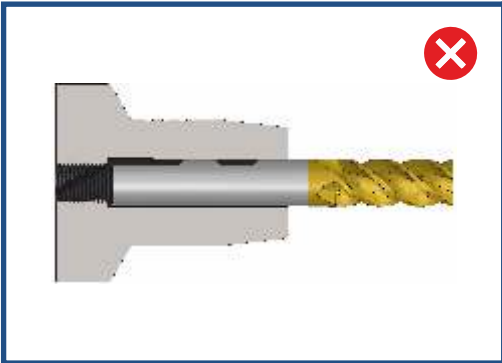

Technical Information

Recommended Torque Values (Tightening Torque / Slipping Torque)

Hydraulic Chuck (Heavy Duty) : Metric Series

Holder Size	Tool Shank Dia. Tolerance	Minimum Clamping Depth (mm)	Maximum Safe Transferable Torque (Nm)
HC 12S	h6	38	110 Nm
HC 20 S	h6	43	520 Nm
HC 32 S	h6	53	900 Nm

Hydraulic Chuck (HC) : Metric Series

Holder Size	Tool Shank Dia. & Tolerance	Minimum Clamping Depth (mm)	Maximum Safe Transferable Torque (Nm)
HC 06	Ø 6.0 h6	28	16 Nm
HC 08	Ø 8.0 h6	28	23 Nm
HC 10	Ø 10.0 h6	33	45 Nm
HC 12	Ø 12.0 h6	38	90 Nm
HC 14	Ø 14.0 h6	38	110 Nm
HC 16	Ø 16.0 h6	41	185 Nm
HC 18	Ø 18.0 h6	41	240 Nm
HC 20	Ø 20.0 h6	43	330 Nm
HC 25	Ø 25.0 h6	49	450 Nm
HC 32	Ø 32.0 h6	53	650 Nm

Hydraulic Chuck (Heavy Duty) : Inches Series

Holder Size	Tool Shank Dia. Tolerance	Minimum Clamping Depth (mm)	Maximum Safe Transferable Torque (Nm)
HC 1/2" HD	h6	38	110 Nm
HC 5/8" HD	h6	41	185 Nm
HC 3/4" HD	h6	43	520 Nm

Hydraulic Chuck (HC) : Inches Series

Holder Size	Tool Shank Dia. & Tolerance	Minimum Clamping Depth (mm)	Maximum Safe Transferable Torque (Nm)
HC 1/4"	Ø 1/4" h6	28	16 Nm
HC 3/8"	Ø 3/8" h6	33	45 Nm
HC 1/2"	Ø 1/2" h6	38	90 Nm
HC 5/8"	Ø 5/8" h6	41	185 Nm
HC 3/4"	Ø 3/4" h6	43	330 Nm
HC 1.0"	Ø 1.0" h6	49	450 Nm
HC 1-1/4"	Ø 1-1/4" h6	53	650 Nm

The logo for Sigma Toolings is a white triangle pointing to the right, set against a teal background. Inside the triangle, the word "SIGMA" is written in a bold, teal, sans-serif font, and the word "TOOLINGS" is written below it in a bold, black, sans-serif font.

SIGMA
TOOLINGS

Sigma Toolings India Pvt Ltd

Office: Gut No. 254, Borhadewadi,
Dehu-Alandi Road, Moshi, Pune-412 105 (M.S)

Factory: G-39/20, MIDC Waluj, Aurangabad.

Call: +91 92722 22511 / +91 76206 05260

Email: pune@sigmatoolings.com /
info@sigmatoolings.com