

**Rough/  
Semifinish  
Boring  
Heads**

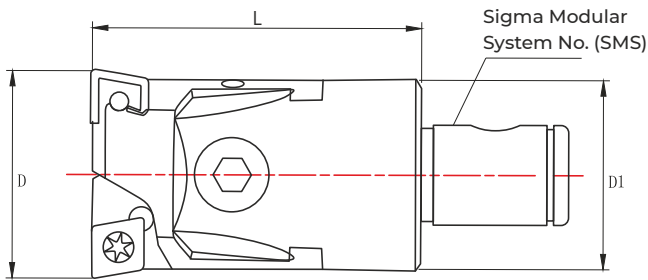

Standard Fine Boring Head



ORDER CODE	SMS	ØD1	L	ØD	INSERT TYPE	INSERT CLAMPING SCREW
SRBH22-28	0	21	40	22-28	CC..0602	CS-2.5
SRBH27-35	1	23	40	27-35	CC..0602	CS-2.5
SRBH34-44	2	29	45	34-44	CC..09T3	CS-4
SRBH43-55	3	37	55	43-55	CC..1204	CS-5
SRBH54-76	4	48	60	54-76	CC..1204	CS-5
SRBH75-105	5	60	75	75-105	CC..1204	CS-5
SRBH104-150	6	80	90	104-150	CC..1204	CS-5

Spares Table

ORDERING CODE	CARTRIDGE	ADJUSTING SCREW	ADJUSTING WRENCH	TIGHTENING SCREW	TIGHTENING WRENCH	INSERT SCREW WRENCH
SRBH22-28	SC22-28	TM3-7L	1.5mm	CTBSM5	4mm	T8
SRBH27-35	SC27-35	TM3-8L	1.5mm	CTBSM5	4mm	T8
SRBH34-44	SC34-44	TM4-10L	2mm	CTBSM6	5mm	T15
SRBH43-55	SC43-55	TM5-12L	2.5mm	CTBSM8	6mm	T20
SRBH54-76	SC54-76	TM6-16L	3mm	CTBSM10	8mm	T20
SRBH75-105	SC75-105	TM8-20L	4mm	CTBSM12	10mm	T20
SRBH104-150	SC104-150	TM8-27L	4mm	CTBSM16	14mm	T20

Through Hole Type Fine Boring Head

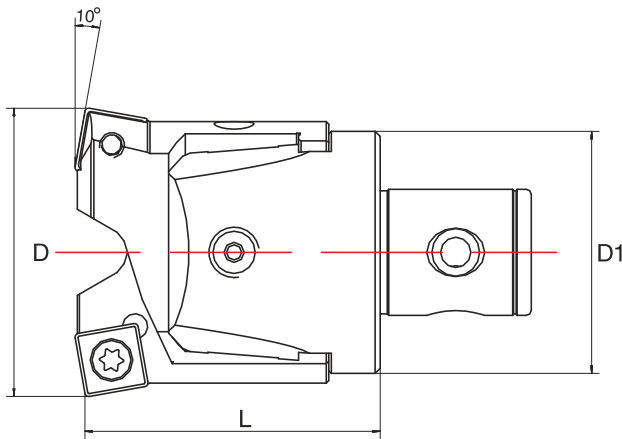

ORDER CODE	SMS	ØD1	L	ØD	INSERT TYPE	INSERT CLAMPING SCREW
SRBH22-28 H	0	21	38	22-28	SC..0702	CS-2.5
SRBH27-35 H	1	23	38	27-35	SC..0702	CS-2.5
SRBH34-44 H	2	29	43	34-44	SC..09T3	CS-4
SRBH43-55 H	3	37	53	43-55	SC..1204	CS-5
SRBH54-76 H	4	48	58	54-76	SC..1204	CS-5
SRBH75-105 H	5	60	73	75-105	SC..1204	CS-5
SRBH104-150 H	6	80	88	104-150	SC..1204	CS-5

2-Stepped Fine Boring Head

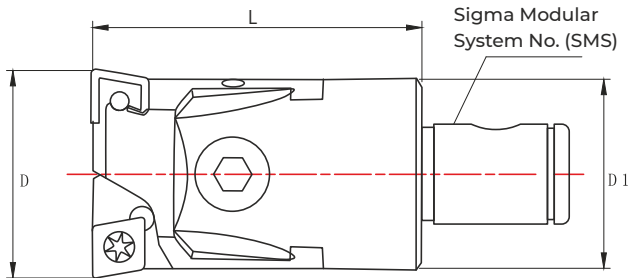

ORDER CODE	SMS	ØD1	L	ØD	INSERT TYPE	INSERT CLAMPING SCREW
SRBH22-28 S	0	21	40	22-28	CC..0602	CSTB-2.5
SRBH27-35 S	1	23	40	27-35	CC..0602	CSTB-2.5
SRBH34-44 S	2	29	45	34-44	CC..09T3	CSTB-4
SRBH43-55 S	3	37	55	43-55	CC..1204	CSTB-5
SRBH54-76 S	4	48	60	54-76	CC..1204	CSTB-5
SRBH75-105 S	5	60	75	75-105	CC..1204	CSTB-5
SRBH104-150 S	6	80	90	104-150	CC..1204	CSTB-5