

Plunging /Milling Chamfer Tools



Sigma Chamfer tools are suitable for plunging as well as milling operations. These are compact, high feed Chamfer Tools in nature which helps in achieving higher speed and feed. It works as multi functional tool which includes chamfering, back chamfering and face milling operations.

Our range of ground inserts and precise inserts avoids vibrations and chatter generated during plunging & chamfering operations.

Plunging Chamfer Milling Tools

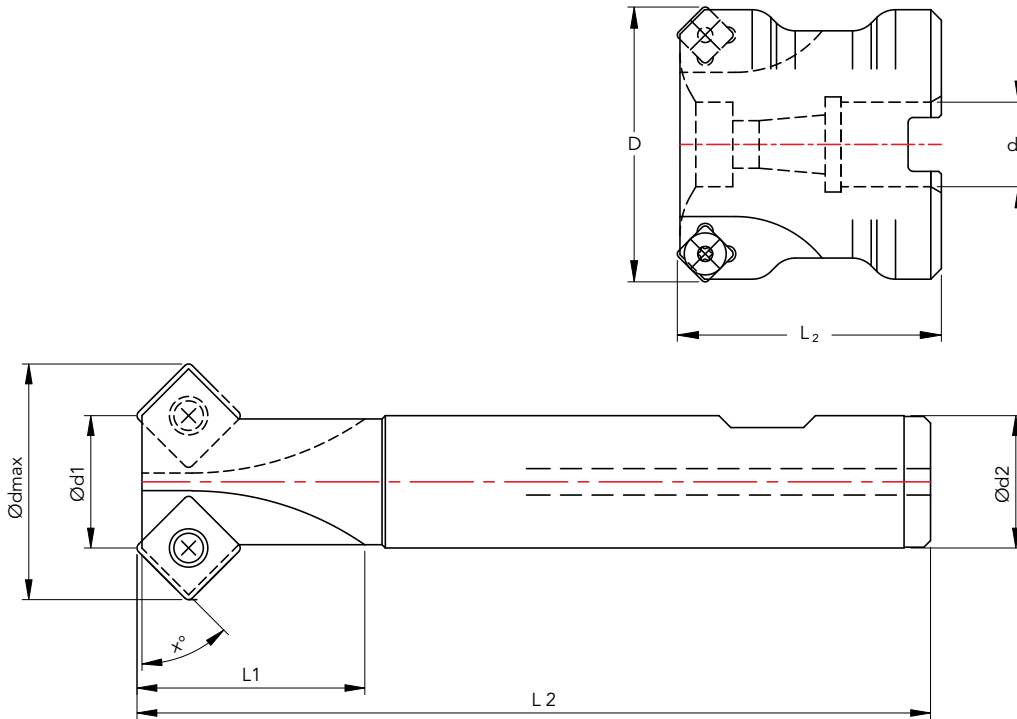

Suitable Insert : SOGX

SIGMA ITEM CODE	DEG.	Z	MAX. TOOL DIA Ø	d1	d2	L1	L2
SCH - 0416D45	45°	1	16.00	4.00	16.00	25.00	100.00
SCH - 0622D45		1	22.00	6.00	20.00	40.00	120.00
SCH - 1531D45		2	31.00	15.00	25.00	50.00	130.00
SCH - 2743D45		3	43.00	27.00	25.00	50.00	130.00
SCH - 3652D45		4	52.00	16.00	-	-	50.00
SCH - 0419D30	30°	1	19.00	4.00	16.00	25.00	100.00
SCH - 0828D30		2	28.00	8.00	20.00	40.00	120.00
SCH - 1030D30		2	30.00	10.00	25.00	50.00	130.00
SCH - 0819D60	60°	1	19.50	8.00	16.00	25.00	100.00
SCH - 2031D60		2	31.00	20.00	25.00	40.00	120.00

Spares

INSERT DESCRIPTION	SCREW	TORX
SOGX - 09	SDG - 3	T9
SOGX - 11	SDG - 4	T10

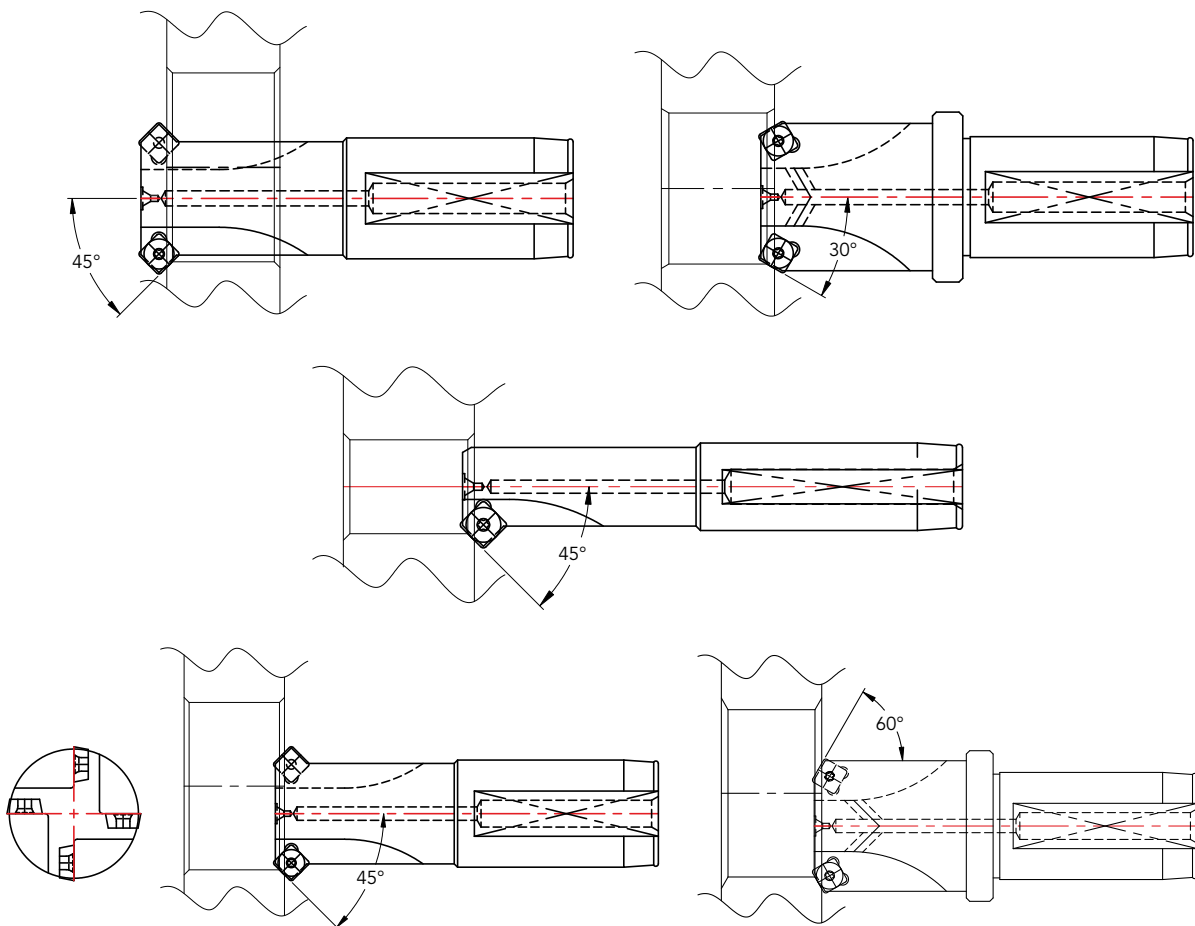
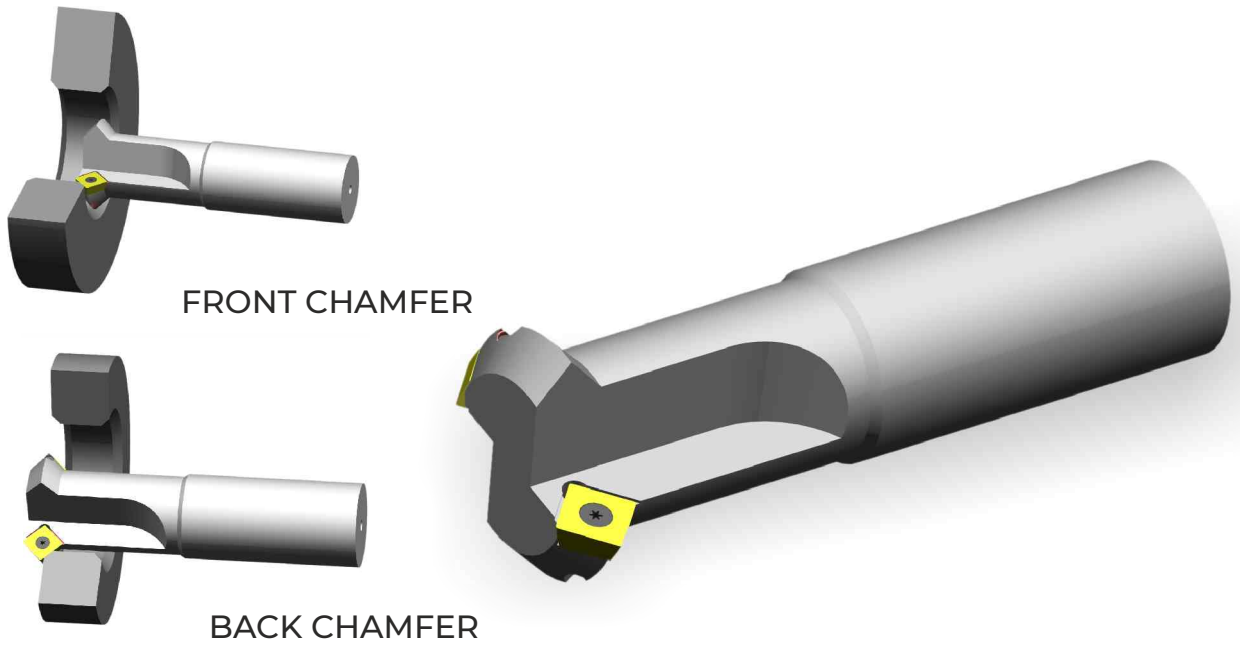

Note : Special Designs and Sizes are Available on Request