

ISO Cartridges



We manufacture all range of ISO Cartridges for boring and chamfering applications.

Cartridges save your tool body from accidental damages. They are replaceable and have small radial and axial adjustment.

S-Style For TCMT Insert

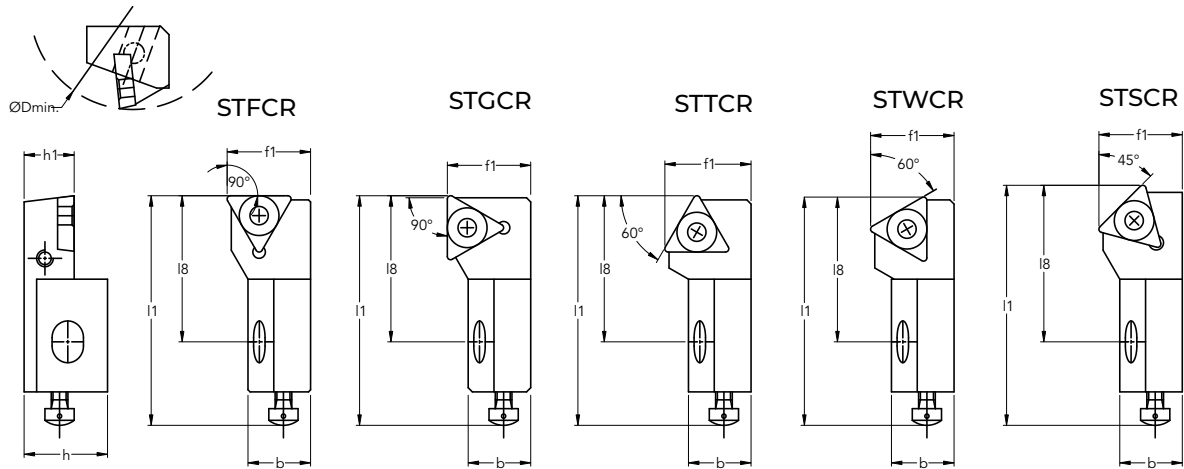

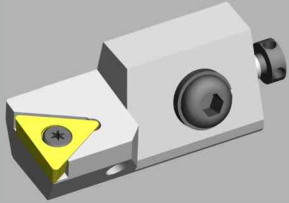
	ORDER CODE	ØD min	f1	h1	b	h	l1	l8	SUITABLE INSERT
	STFCR/L 06CA-06T1	20.0	8.0	6.0	6.0	8.5	25.0	13.0	TCMT 06
	STFCR/L 08CA-09	25.0	10.0	8.0	8.0	10.0	32.0	15.0	TCMT 09
	STFCR/L 10CA-11	40.0	14.0	10.0	11.0	15.0	50.0	30.0	TCMT 11
	STFCR/L 12CA-16	50.0	20.0	12.0	15.0	20.0	55.0	35.0	TCMT 16
	STFCR/L 16CA-16	55.0	25.0	16.0	20.0	21.0	63.0	38.0	TCMT 16

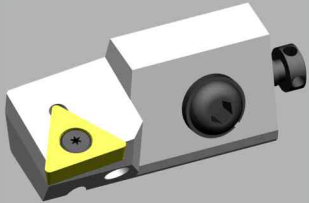
	ORDER CODE	ØD min	f1	h1	b	h	l1	l8	SUITABLE INSERT
	STGCR/L 06CA-06T1	30.0	8.0	6.0	6.0	8.5	25.0	13.0	TCMT 06
	STGCR/L 08CA-09	37.0	10.0	8.0	8.0	10.0	32.0	15.0	TCMT 09
	STGCR/L 10CA-11	55.0	14.0	10.0	11.0	15.0	50.0	30.0	TCMT 11
	STGCR/L 12CA-16	75.0	20.0	12.0	15.0	20.0	55.0	35.0	TCMT 16
	STGCR/L 16CA-16	85.0	25.0	16.0	20.0	21.0	63.0	38.0	TCMT 16

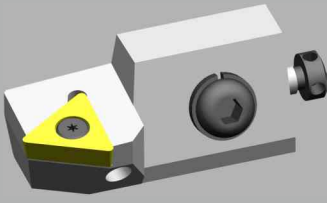
	ORDER CODE	ØD min	f1	h1	b	h	l1	l8	SUITABLE INSERT
	STTCR/L 06CA-06T1	20.0	5.0	6.0	6.0	8.5	25.0	13.0	TCMT 06
	STTCR/L 08CA-09	25.0	6.0	8.0	8.0	10.0	32.0	15.0	TCMT 09
	STTCR/L 10CA-11	40.0	9.0	10.0	11.0	15.0	50.0	30.0	TCMT 11
	STTCR/L 12CA-16	50.0	13.0	12.0	15.0	20.0	55.0	35.0	TCMT 16
	STTCR/L 16CA-16	55.0	15.0	16.0	20.0	21.0	63.0	38.0	TCMT 16

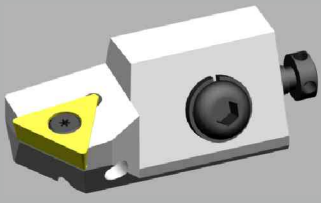
	ORDER CODE	ØD min	f1	h1	b	h	l1	l8	SUITABLE INSERT
	STWCR/L 06CA-06T1	20.0	5.0	6.0	6.0	8.5	24.2	13.0	TCMT 06
	STWCR/L 08CA-09	25.0	6.0	8.0	8.0	10.0	32.2	15.0	TCMT 09
	STWCR/L 10CA-11	40.0	9.0	10.0	11.0	15.0	49.0	30.0	TCMT 11
	STWCR/L 12CA-16	50.0	13.0	12.0	15.0	20.0	54.2	35.0	TCMT 16
	STWCR/L 16CA-16	55.0	15.0	16.0	20.0	21.0	63.2	38.0	TCMT 16

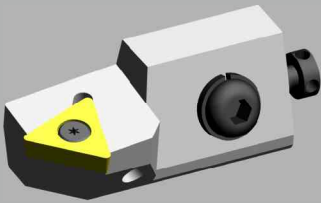
	ORDER CODE	ØD min	f1	h1	b	h	l1	l8	SUITABLE INSERT
	STSCR/L 06CA-06T1	20.0	8.0	6.0	6.0	8.5	25.5	13.0	TCMT 06
	STSCR/L 08CA-09	25.0	10.0	8.0	8.0	10.0	34.1	15.0	TCMT 09
	STSCR/L 10CA-11	40.0	14.0	10.0	11.0	15.0	51.0	30.0	TCMT 11
	STSCR/L 12CA-16	50.0	20.0	12.0	15.0	20.0	57.2	35.0	TCMT 16
	STSCR/L 16CA-16	55.0	25.0	16.0	20.0	21.0	63.2	38.0	TCMT 16

S-Style For CCMT & SCMT Insert

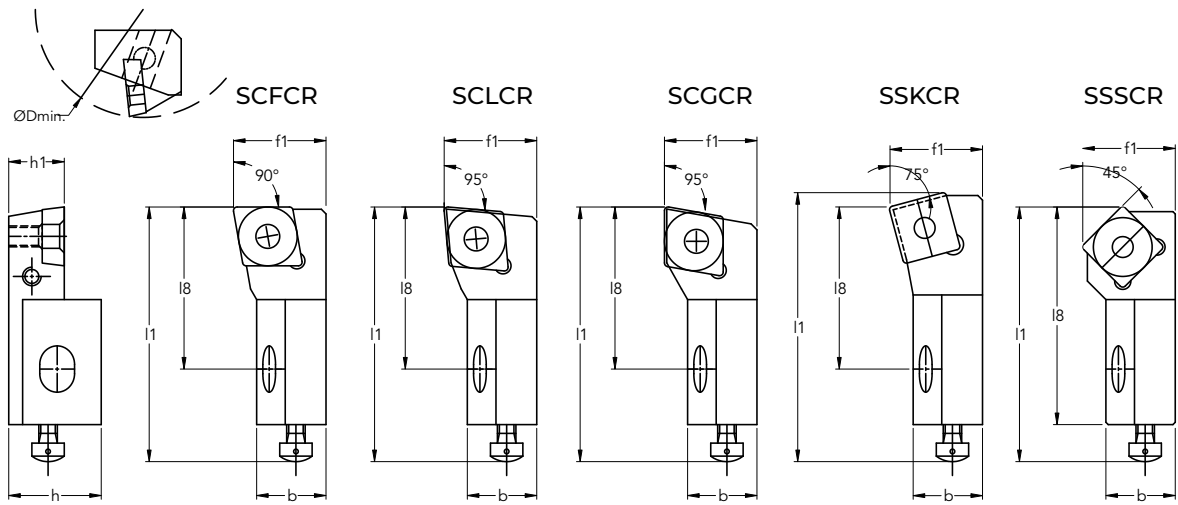

	ORDER CODE	ØD min	f1	h1	b	h	l1	l8	SUITABLE INSERT
	SCFCR/L 08CA-06	25.0	10.0	8.0	8.0	10.0	32.0	15.0	CCMT 06
SCFCR/L 10CA-09T3	40.0	14.0	10.0	11.0	15.0	50.0	30.0	CCMT 09	
SCFCR/L 12CA-12	50.0	20.0	12.0	15.0	20.0	55.0	35.0	CCMT 12	
SCFCR/L 16CA-12	55.0	25.0	16.0	20.0	25.0	63.0	39.0	CCMT 12	

	ORDER CODE	ØD min	f1	h1	b	h	l1	l8	SUITABLE INSERT
	SLCR/L 08CA-06	25.0	10.0	8.0	8.0	10.0	32.0	15.0	CCMT 06
SLCR/L 10CA-09T3	40.0	14.0	10.0	11.0	15.0	50.0	30.0	CCMT 09	
SLCR/L 12CA-12	50.0	20.0	12.0	15.0	20.0	55.0	35.0	CCMT 12	

	ORDER CODE	ØD min	f1	h1	b	h	l1	l8	SUITABLE INSERT
	SCGCR/L 10CA-09T3	55.0	14.0	10.0	11.0	15.0	50.0	30.0	CCMT 09
SCGCR/L 12CA-12	75.0	20.0	12.0	15.0	20.0	55.0	35.0	CCMT 12	
SCGCR/L 16CA-12	85.0	25.0	16.0	20.0	25.0	63.0	39.0	CCMT 12	

	ORDER CODE	ØD min	f1	h1	b	h	l1	l8	SUITABLE INSERT
	SSKCR/L 10CA-09T3	40.0	14.0	10.0	11.0	15.0	50.0	30.0	SCMT 09
SSKCR/L 12CA-12	50.0	20.0	12.0	15.0	20.0	55.0	35.0	SCMT 12	

	ORDER CODE	ØD min	f1	h1	b	h	l1	l8	SUITABLE INSERT
	SSSCR/L 10CA-09T3	40.0	14.0	10.0	11.0	15.0	50.0	30.0	SCMT 09
SSSCR/L 12CA-12	50.0	20.0	12.0	15.0	20.0	55.0	35.0	SCMT 12	

D-Style For TNMG, CNMG & SNMG Insert

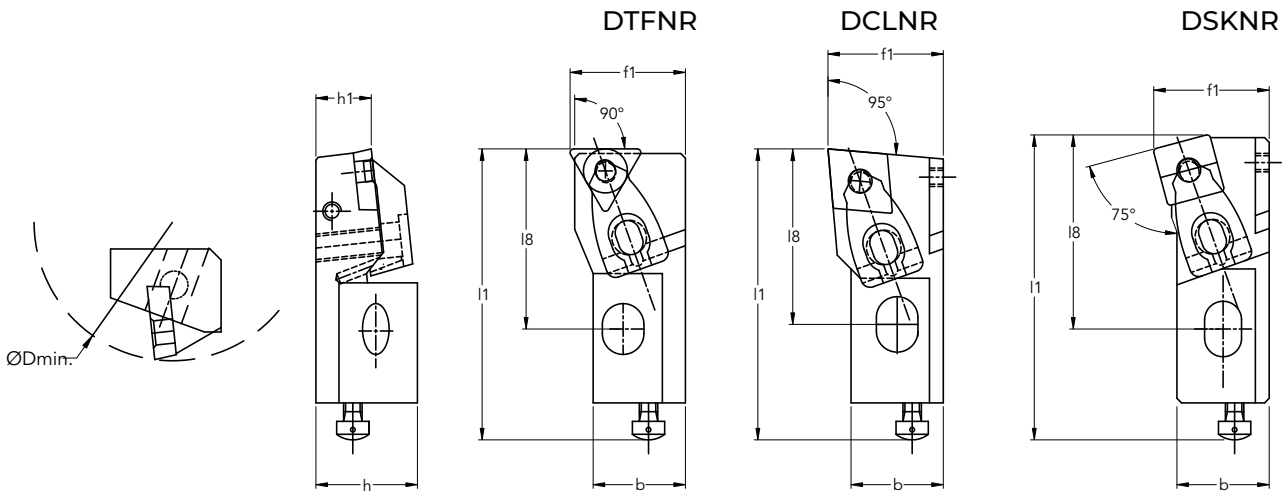

	ORDER CODE	ØD min	f1	h1	b	h	l1	l8	SUITABLE INSERT
	DTFNR/L 16CA-16	55.0	25.0	16.0	20.0	25.0	63.0	39.0	TNMG 16

	ORDER CODE	ØD min	f1	h1	b	h	l1	l8	SUITABLE INSERT
	DCLNR/L 25CA-12	100.0	32.0	25.0	25.0	38.0	100.0	50.0	CNMG 12
	DCLNR/L 25CA-16	100.0	32.0	25.0	25.0	38.0	100.0	50.0	CNMG 16

	ORDER CODE	ØD min	f1	h1	b	h	l1	l8	SUITABLE INSERT
	DSKNR/L 25CA-12	100.0	32.0	25.0	25.0	38.0	100.0	50.0	SNMG 12

Note : Special Designs and Sizes are Available on Request

P-Style For CNMG Insert

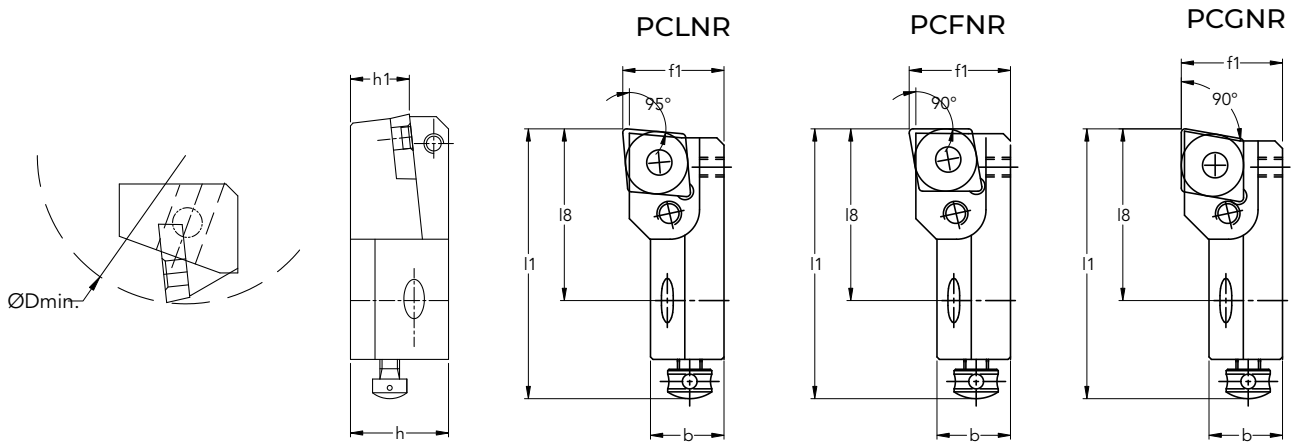

	ORDER CODE	ØD min	f1	h1	b	h	l1	l8	SUITABLE INSERT
	PCLNR/L 12CA-12	50.0	20.0	12.0	15.0	20.0	55.0	35.0	CNMG 12
PCLNR/L 16CA-12	55.0	25.0	16.0	20.0	25.0	63.0	39.0	CNMG 12	
PCLNR/L 25CA-19	100.0	32.0	25.0	25.0	38.0	100.0	50.0	CNMG 19	

	ORDER CODE	ØD min	f1	h1	b	h	l1	l8	SUITABLE INSERT
	PCFNR/L 12CA-12	50.0	20.0	12.0	15.0	20.0	55.0	35.0	CNMG 12
PCFNR/L 16CA-12	55.0	25.0	16.0	20.0	25.0	63.0	39.0	CNMG 12	

	ORDER CODE	ØD min	f1	h1	b	h	l1	l8	SUITABLE INSERT
	PCGNR/L 12CA-12	75.0	20.0	12.0	15.0	20.0	55.0	35.0	CNMG 12
PCGNR/L 16CA-12	75.0	25.0	16.0	20.0	25.0	63.0	39.0	CNMG 12	

P-Style For TNMG Insert

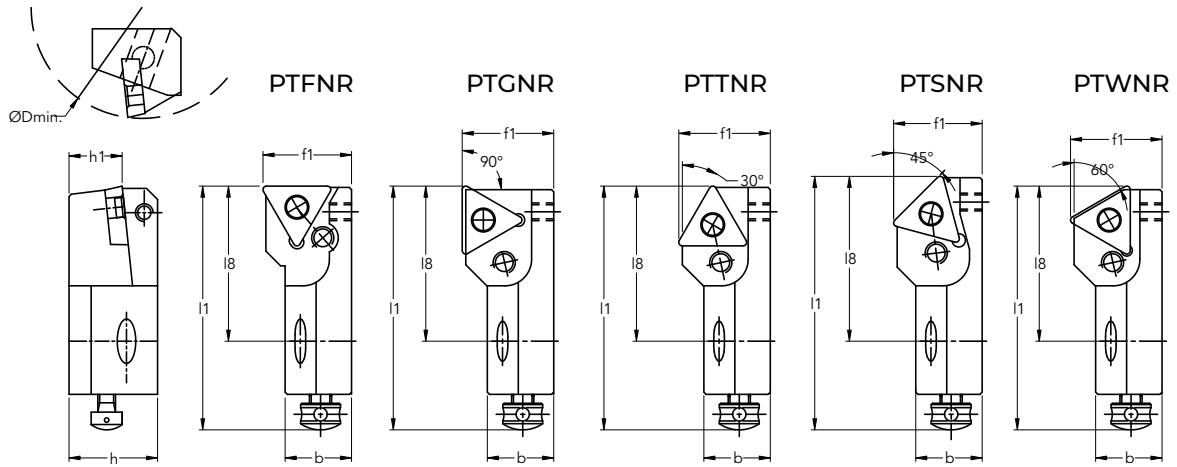

	ORDER CODE	ØD min	f1	h1	b	h	l1	l8	SUITABLE INSERT
	PTFNR/L 12CA-16	50.0	20.0	12.0	15.0	20.0	55.0	35.0	TNMG-16
PTFNR/L 16CA-16	55.0	25.0	16.0	20.0	25.0	63.0	39.0	TNMG-16	
PTFNR/L 20CA-22	70.0	25.0	20.0	20.0	30.0	70.0	40.0	TNMG-22	

	ORDER CODE	ØD min	f1	h1	b	h	l1	l8	SUITABLE INSERT
	PTGNR/L 12CA-16	75.0	20.0	12.0	15.0	20.0	55.0	35.0	TNMG-16
PTGNR/L 16CA-16	75.0	25.0	16.0	20.0	25.0	63.0	39.0	TNMG-16	
PTGNR/L 20CA-22	90.0	25.0	20.0	20.0	30.0	70.0	40.0	TNMG-22	

	ORDER CODE	ØD min	f1	h1	b	h	l1	l8	SUITABLE INSERT
	PTTNR/L 12CA-16	50.0	20.0	12.0	15.0	20.0	55.0	35.0	TNMG-16
PTTNR/L 16CA-16	55.0	25.0	16.0	20.0	25.0	63.0	39.0	TNMG-16	

	ORDER CODE	ØD min	f1	h1	b	h	l1	l8	SUITABLE INSERT
	PTSNR/L 12CA-16	50.0	20.0	12.0	15.0	20.0	57.2	27.0	TNMG-16
PTSNR/L 16CA-16	55.0	25.0	16.0	20.0	25.0	63.2	29.0	TNMG-16	
PTSNR/L 20CA-22	70.0	25.0	20.0	20.0	30.0	74.1	30.0	TNMG-22	

	ORDER CODE	ØD min	f1	h1	b	h	l1	l8	SUITABLE INSERT
	PTWNR/L 12CA-16	50.0	20.0	12.0	15.0	20.0	54.2	27.0	TNMG-16

P-Style For SNMG Insert

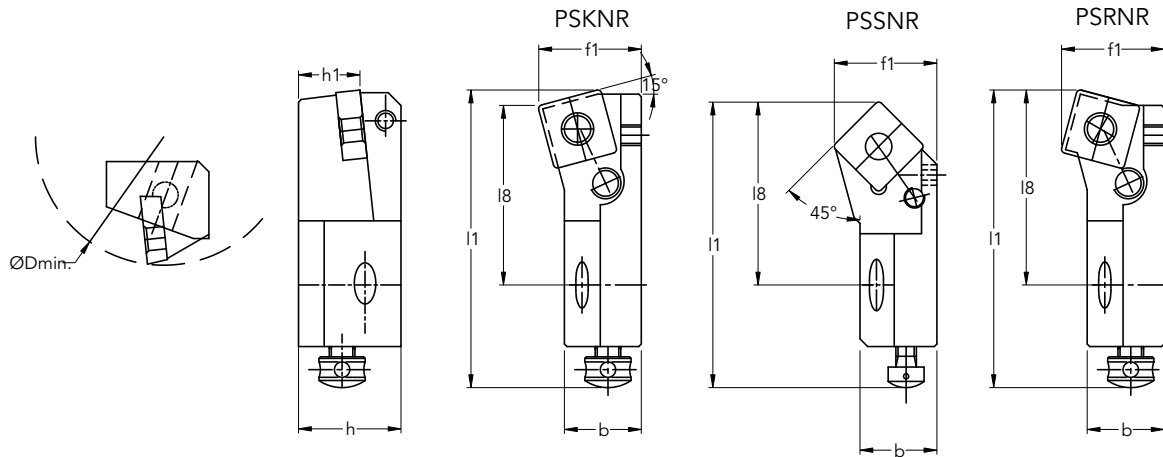

	ORDER CODE	ØD min	f1	h1	b	h	l1	l8	SUITABLE INSERT
	PSKNR/L 12CA-12	50.0	20.0	12.0	15.0	20.0	55.0	35.0	SNMG 12
	PSKNR/L 16CA-12	55.0	25.0	16.0	20.0	25.0	63.0	39.0	SNMG 12
	PSKNR/L 20CA-15	70.0	25.0	20.0	20.0	30.0	73.7	40.0	SNMG 15
	PSKNR/L 25CA-19	100.0	32.0	25.0	25.0	38.0	100.0	50.0	SNMG 19

	ORDER CODE	ØD min	f1	h1	b	h	l1	l8	SUITABLE INSERT
	PSSNR/L 12CA-12	50.0	20.0	12.0	15.0	20.0	55.0	35.0	CNMG 12
	PSSNR/L 16CA-12	55.0	25.0	16.0	20.0	25.0	63.0	39.0	CNMG 12
	PSSNR/L 20CA-15	70.0	25.0	20.0	20.0	30.0	73.7	40.0	SNMG 15

	ORDER CODE	ØD min	f1	h1	b	h	l1	l8	SUITABLE INSERT	
	PSRNR/L 16CA-12	55.0	25.0	16.0	20.0	25.0	63.0	39.0	CNMG 12	
	PSRNR/L 20CA-15	70.0	25.0	20.0	20.0	30.0	73.7	40.0		

Mounting Dimensions for P-Type & D-Type Cartridges

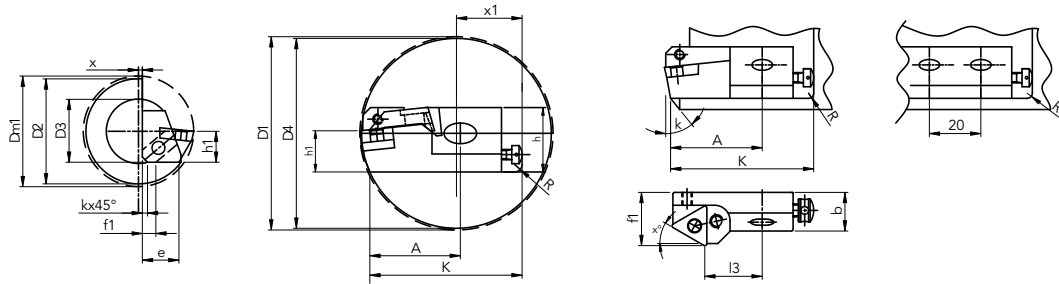

CARTRIDGE SIZE	ORDER CODE	K°	h1	D min	D1 min	e	f1	l8	K	A	R max	Ch max
12CA 	PTFNR/L 12CA-16	90°	12.0	50.0		14.0		35.0	53.0	33.0	5.0	0.4
	PTGNR/L 12CA-16	90°			75.0		35.0	50.5	30.5			
	PTWNR/L 12CA-16	60°					3.5	27.0	50.5	30.5		
	PTTNR/L 12CA-16	60°			75.0		10.5	35.0	50.5	30.5		
	PTSNR/L 12CA-16	45°					6.5	27.0	53.5	33.5		
	PCLNR/L 12CA-12	95°						35.0	53.0	33.0		
	PCFNR/L 12CA-12	90°						35.0	53.0	33.0		
	PCGNR/L 12CA-12	90°						35.0	50.5	30.5		
	PSKNR/L 12CA-12	75°					1.0	35.0	56.5	36.5		
	PSSNR/L 12CA-12	45°						27.0	52.0	32.0		
16CA 	PTFNR/L 16CA-16	90°	16.0	55.0		17.5		38.0	60.0	35.0	6.0	0.4
	PTGNR/L 16CA-16	90°		60.0	75.0	17.0		38.0	57.0	32.0		
	PTTNR/L 16CA-16	60°		55.0		19.0		39.0	57.0	34.5		
	PTSNR/L 16CA-16	45°		55.0		17.0	11.5	28.0	57.5	32.5		
	PCLNR/L 16CA-12	95°		55.0	75.0	17.5		38.0	57.0	32.0		
	PCFNR/L 16CA-12	90°		55.0		17.5		38.0	59.0	34.0		
	PCGNR/L 16CA-12	90°		60.0	75.0	18.5		38.0	55.5	30.5		
	PSKNR/L 16CA-12	75°		55.0		17.5	6.0	38.0	63.5	38.5		
	PSSNR/L 16CA-12	45°		55.0	75.0	17.0		28.0	56.5	31.5		
	PSRNR/L 16CA-12	75°		55.0	75.0	19.0		38.0	52.5	27.5		
	DTFNR/L 16CA-16	90°		55.0		18.5		39.0	61.0	37.5		
20CA 	PTFNR/L 20CA-22	90°	20.0	70.0		15.5		40.0	67.0	37.0	6.0	0.4
	PTGNR/L 20CA-22	90°			90.0	16.0		40.0	62.5	32.5		
	PTSNR/L 20CA-22	45°				15.5	6.9	30.0	67.0	37.0		
	PSKNR/L 20CA-15	75°				16.5	1.3	40.0	71.0	41.0		
	PSSNR/L 20CA-15	45°				15.5		30.0	65.0	35.0		
	PSRNR/L 20CA-15	75°				90.0	18.0		40.0	63.0		
25CA 	PCLNR/L 25CA-19	95°	25.0	100.0	115.0			50.0	91.5	41.5	7.0	0.7
	PSKNR/L 25CA-19	95°						50.0	101.6	51.6		
	DCLNR/L 25CA-12	95°			115.0			50.0	91.5	43.6		
	DCLNR/L 25CA-16	95°			115.0			50.0	91.5	43.6		
	DSKNR/L 25CA-12	75°						50.0	101.6	51.6		

Mounting Dimensions for S-Type Cartridges

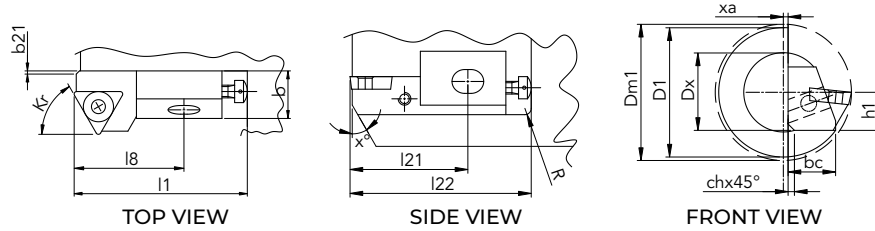

CARTRIDGE SIZE	ORDER CODE	K°	h1	D min	D1 min	e	f1	l8	K	A	R max	Ch max			
06CA 	STFCR/L 06CA-06T1	90°	6.0	20.0	30.0	5.0	3.4	13.0	24.0	12.0	1.5	0.3			
	STGCR/L 06CA-06T1	90°						13.0	23.0	11.0					
	STTCR/L 06CA-06T1	60°						9.0	23.0	11.0					
	STSCR/L 06CA-06T1	45°						2.5	9.0	23.0			11.0		
	STWCR/L 06CA-06T1	60°						1.2	9.0	22.5			10.5		
08CA 	STFCR/L 08CA-09	90°	8.0	25.0	37.0	6.0	2.7	15.0	30.5	13.5	2.5	0.3			
	STGCR/L 08CA-09	90°						11.0	29.2	12.2					
	STTCR/L 08CA-09	60°						11.0	29.2	12.2					
	STSCR/L 08CA-09	45°						11.0	30.5	13.5					
	STWCR/L 08CA-09	60°						0.8	11.0	30.0			13.0		
	SCFCR/L 08CA-06	90°						15.0	30.5	13.5					
	SCLCR/L 08CA-06	95°						11.0	29.2	12.2					
10CA 	STFCR/L 10CA-11	90°	10.0	40.0	55.0	9.0	1.2	35.0	47.5	27.5	4.0	0.4			
	STGCR/L 10CA-11	90°						35.0	46.5	26.5					
	STTCR/L 10CA-11	60°						6.1	35.0	48.0			28.0		
	STSCR/L 10CA-11	45°						3.0	27.0	49.0			29.0		
	STWCR/L 10CA-11	60°						27.0	47.0	27.0					
	SCFCR/L 10CA-09T3	90°						35.0	47.5	27.5					
	SCLCR/L 10CA-09T3	95°						35.0	47.5	27.5					
	SSKCR/L 10CA-09T3	75°						0.9	35.0	50.5			30.5		
	SSSCR/L 10CA-09T3	45°						27.0	47.0	27.0					
12CA 	STFCR/L 12CA-16	90°	12.0	50.0	75.0	13.0	4.2	35.0	53.2	33.2	5.0	0.4			
	STGCR/L 12CA-16	90°						15.0	35.0	51.0			31.0		
	STTCR/L 12CA-16	60°						7.5	13.0	9.8			35.0	53.0	33.0
	STSCR/L 12CA-16	45°						13.0	5.4	27.0			55.0	35.0	
	STWCR/L 12CA-16	60°						27.0	52.0	32.0					
	SCFCR/L 12CA-12	90°						13.0	35.0	53.2			33.2		
	SCLCR/L 12CA-12	95°						13.0	35.0	53.0			33.2		
	SSKCR/L 12CA-12	75°						13.5	3.1	35.0			56.0	36.0	
	SSSCR/L 12CA-12	45°						7.5	13.0	27.0			51.5	31.5	
16CA 	STFCR/L 16CA-16	90°	16.0	55.0	17.0	38.0	61.0	36.0	6.0	0.4					
	STGCR/L 16CA-16	90°		60.0	75.0	18.5	38.0	57.0			32.0				
	STTCR/L 16CA-16	60°		60.0	75.0	17.5	11.5	38.0			60.5	35.5			
	STSCR/L 16CA-16	45°		55.0	16.5	7.1	28.0	60.5			35.5				
	STWCR/L 16CA-16	60°		55.0	16.5	4.9	28.0	57.5			32.5				
	SCFCR/L 16CA-12	90°		55.0	17.0	38.0	61.0	36.0							